



**TECHNICAL
REGULATIONS E-XPLORER
2024**



Technical Rules E-Xplorer

15.01.2024

Version 0
Applicable as from 01.01.2024

YEAR 2024		
Version	Applicable as from	Modified paragraphs
0	01.01.2024	01, 01.05, 02.02, 02.03, 02.13, 02.16.01, 02.17.09, 02.17.10, 02.17.11, 03.04; 03.05.02, 04

TABLE OF CONTENTS

01	INTRODUCTION.....	3
01.01	FREEDOM OF CONSTRUCTION.....	3
01.02	DEFINITION OF A PROTOTYPE.....	3
01.03	DEFINITION OF A FRAME OF A SOLO MOTORCYCLE.....	3
01.04	GENERAL VEHICLE SPECIFICATIONS.....	3
01.05	CATEGORIES/GROUPS/CLASSES ARE AS FOLLOWS.....	4
02	REQUIREMENTS.....	4
02.01	POWER.....	4
02.02	OVERALL DIMENSIONS.....	4
02.03	MOTORCYCLE WEIGHTS.....	5
02.04	INCLINATION.....	5
02.05	MATERIALS.....	5
02.06	OPEN TRANSMISSION GUARDS.....	6
02.07	HANDLEBARS.....	7
02.08	CONTROL LEVERS.....	7
02.09	FOOTRESTS.....	8
02.10	BRAKES.....	8
02.11	MUDGUARDS AND WHEEL PROTECTION.....	8
02.12	THROTTLE.....	9
02.13	IGNITION CUT-OUT SWITCH.....	9
02.14	STREAMLINING.....	9
02.15	SUSPENSION.....	10
02.16	WHEELS, RIMS, TYRES.....	10
02.17	ELECTRICAL.....	11
02.18	DATA RECORDING.....	16
02.19	NUMBER PLATES.....	17
03	EQUIPMENT AND PROTECTIVE CLOTHING DURING PRACTICE AND RACE.....	17
03.01	CLOTHING AND PROTECTORS.....	17
03.02	FOOTWEAR.....	18
03.03	GLOVES.....	18
03.04	EYE PROTECTION.....	18
03.05	WEARING OF HELMETS.....	18
03.06	BADGE OF THE FIM.....	21
03.07	NUMBER SASHES (BIBS).....	21
03.08	TEAM STAFF EQUIPMENT OPERATED ON ELECTRIC CIRCUIT OF THE MOTORCYCLE.....	22
04	TECHNICAL VERIFICATIONS.....	22
04.01	CONFORMITY.....	23
04.02	PREPARATION.....	23
04.03	VERIFICATIONS.....	24
04.04	FMNR CHIEF TECHNICAL STEWARD AND TECHNICAL STEWARDS.....	25
04.05	FIM TECHNICAL DIRECTOR.....	26
04.06	RIDER AND/OR MECHANIC.....	27
04.07	DANGEROUS MACHINES.....	28

Any references to the male gender in this document are made solely for the purpose of simplicity and refer also to the female gender except when the context requires otherwise.

01 INTRODUCTION

The FIM E-XPLORER WORLD CUP is reserved for electric polyvalent all-terrain motorcycles.

The technical concept of an electric polyvalent all-terrain motorcycle is a ~~lightweight~~ motorcycle (~~75kg or 165 Lbs < Weight < 130Kg or 286 Lbs~~) that is propelled by an electric motor without pedals and that is designed to ride in different surfaces.

The technical concept is reserved to solo motorcycles powered by an electric motor without pedals and by the action of one wheel in contact with the ground

The number of electric motors in the motorcycle is limited to one.

Amendments to these technical regulations may be made at any time in order to ensure fair competitions.

01.01 FREEDOM OF CONSTRUCTION

A motorcycle must conform to the requirements of the FIM regulations, to the Supplementary Regulations, as well as to a number of specific conditions that the FIM may require for certain competitions. No restriction is placed on the make, construction or type of motorcycle used.

01.02 DEFINITION OF A PROTOTYPE

A prototype motorcycle is a vehicle which must conform to the safety requirements as required by the FIM Sporting Code and Appendices applicable to the type of competition for which it is to be used.

01.03 DEFINITION OF A FRAME OF A SOLO MOTORCYCLE

The structure or structures used to join any steering mechanism at the front of the machine to the motor/gear box unit and to all components of the rear suspension.

01.04 GENERAL VEHICLE SPECIFICATIONS

All motorcycles must comply in every respect with all the requirements for racing as specified in the FIM General Technical Specifications, unless otherwise specified below.

For the purpose of the following technical specifications, the power circuit consists of all those parts of the electrical equipment which are used to propel the motorcycle. The on-board circuit consists of all those parts of the electrical equipment which are used for signalling, lighting or communication. The accumulator is defined as any on-board equipment used for the storage of electrical energy supplied by the charging unit.

Recovering energy generated by the kinetic energy of the vehicle is permitted.

The use of any external source of energy in any form whatsoever with the aim of improving the performance of the vehicle is strictly prohibited.

The following specifications apply to all vehicles taking part in the FIM E-XPLORER WORLD CUP.

They should also be applied to all national competitions unless the FMNR (National Motorcycling Federation) has otherwise directed.

Further specifications for some competitions may also be required and these will be detailed in either the appropriate FIM Appendix or in the Supplementary Regulations for the competition in question.

Concerning material verification, in case of doubt, a sample or the part in question shall be taken and analysed at a Material Testing laboratory.

01.05 CATEGORIES/GROUPS/CLASSES ARE AS FOLLOWS

- **Category “HYPERBIKE”:** e-Motorcycles based on:
 - **The Hyperbike class represents the premier division in the FIM E-Xplorer World Cup. This class welcomes both specialized prototype models and production-based vehicles. Its primary objective is to evaluate and advance the latest technologies in electric power units**

- **Category “GT”:** e-Motorcycles based on:
 - **The GT class in 2024 is centered on production models that are sold or available in the market. This approach aims to reduce racing budgets for private teams looking to enter the competition.**

By the 2026/27 season, FIM E-Xplorer World Championship plan is to establish two distinct GT classes: the GT1, featuring production-based full-size motorcycles, and the GT2, comprising lighter and more compact production-based motorcycles. The GT1 class will allow the Hyperbike class to be exclusively dedicated to prototypes.

02 REQUIREMENTS

02.01 POWER

Unlimited

02.02 OVERALL DIMENSIONS

The following specific dimensions for the vehicles of this discipline apply.

- ~~Wheelbase min 1310 [mm]~~
- ~~Wheelbase max 1490 [mm]~~

	Wheelbase
GT	1325 [mm] to 1460 [mm]
HYPERBIKE	Free

02.03 MOTORCYCLE WEIGHTS

~~The minimum weights of the motorcycles (without rider and/or passenger, with all operational fluids and battery) are: 75[kg]~~

~~The maximum weights of the motorcycles (without rider and/or passenger, with all operational fluids and battery) are: 130[kg]~~

	Weight
GT	≥ 85 [kg] <100 [kg]
HYPERBIKE	≥ 100 [kg]

These are absolute limits and no tolerance is applied when the machine is checked before the practice/qualifying race/race.

The minimum weight of the verified motorcycle must not at any time be less than the minimum weight required.

A 1% tolerance in the weight of the machine is accepted when checked during or after the race, in order to take into account the variability of the test conditions.

A scale with a minimum resolution of 100[g] must be used.

The use of ballast to stay over the minimum weight is forbidden. The term "ballast" refers to as any component, device or part, the primary function of which is to add weight to the machine. All components, devices and parts must be firmly fixed to the motorcycle.

02.04 INCLINATION

It must be possible for a motorcycle not being loaded, to be inclined to an angle of 40 degrees from the vertical, without any part of it other than the tyres coming in contact with the ground.

In race conditions, the vehicle must be capable of affecting a standing start on an uphill slope with a gradient of 18%.

02.05 MATERIALS

02.05.01 Use of titanium and light alloys

The use of titanium and light alloys parts is allowed.

02.05.02 Carbon fibre

The use of carbon fibre reinforced materials is authorised (with the exception of handlebars and wheel rims).

02.05.03 Ceramic materials

The use of ceramic parts is allowed.

02.06 OPEN TRANSMISSION GUARDS

A guard must be fitted to the countershaft sprocket.

If the primary transmission is exposed, it must be fitted with a guard as a safety measure. The guard must be designed so that rider or the passenger cannot under any circumstances come into accidental contact with the transmission parts. It must be designed to protect the rider from injuring his fingers. (See Figure 1)

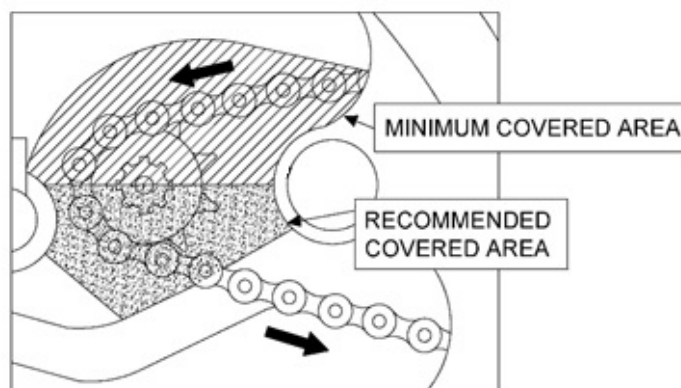

Figure 1

A chain guard must be fitted in such a way to prevent trapping between the lower chain run and the final driven sprocket at the rear wheel. (See Figure 2)

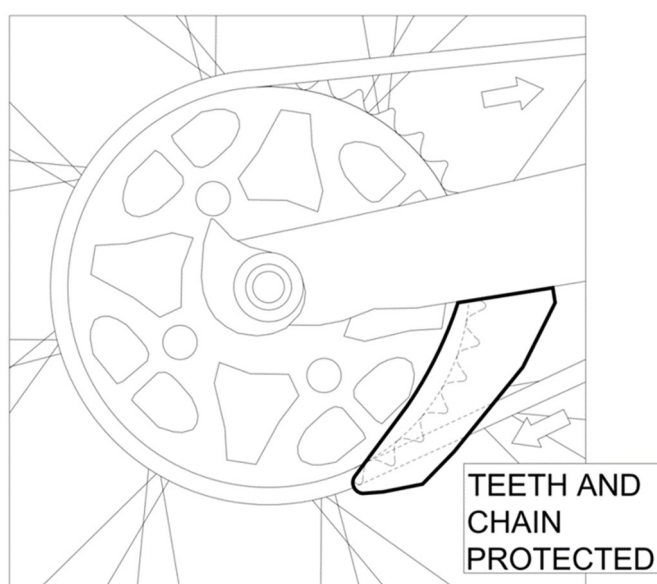

Figure 2

02.07 HANDLEBARS

The width of handlebars must be not less than 600 [mm] and not more than 850 [mm] (See Figure 4)

The handlebars must be equipped with a protection pad on the cross bar. Handlebars without a cross member must be equipped with a protection pad located in the middle of the handlebars, covering widely the handlebars clamps. (See Figure 3)

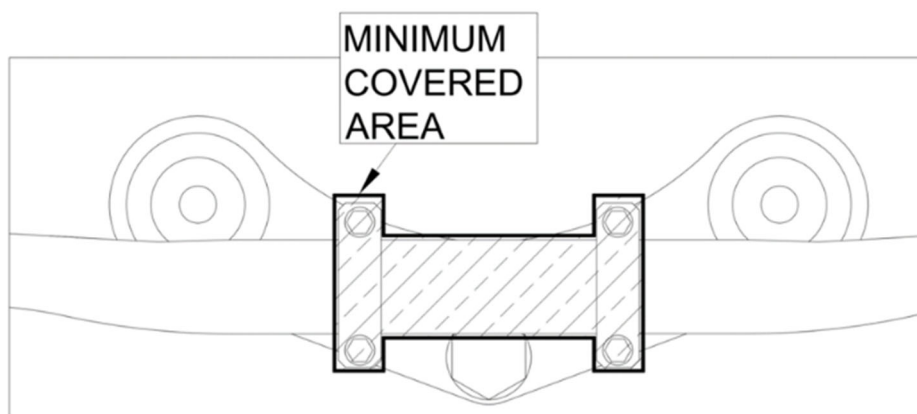

Figure 3

Handlebar clamps must be very carefully radiused and engineered so as to avoid any fracture points in the handlebar.

Exposed handlebar ends must be plugged with a solid material or rubber covered.

When hand protectors are used, these must be made of a shatter-resistant material and have a permanent opening for the hand.

Handlebars made of composite materials are not authorised.

Repair by welding of light alloy handlebars is prohibited.

Solid stops (when on full-lock, other than steering dampers) must be fitted. These must ensure a minimum clearance of 30 [mm] between the handlebar with levers and the tank to prevent trapping the rider's fingers.

02.08 CONTROL LEVERS

All handlebar levers (clutch, brake, etc.) must be in principle ball ended (diameter of this ball to be at least 10 [mm] (16 [mm] recommended), (see Diagrams). This ball can also be flattened, but in any case, the edges must be rounded (recommended: minimum thickness of this flattened part 14 [mm]). These ends must be permanently fixed and form an integral part of the lever. If the gear lever consists of a tube, then its edge must be rounded. (See Figure 4)

Each control lever (hand and foot levers) must be mounted on an independent pivot.

The brake lever if pivoted on the footrest axis must work under all circumstances, such as the footrest being bent or deformed.

Hand- and foot-controls may be modified according to rider preferences.

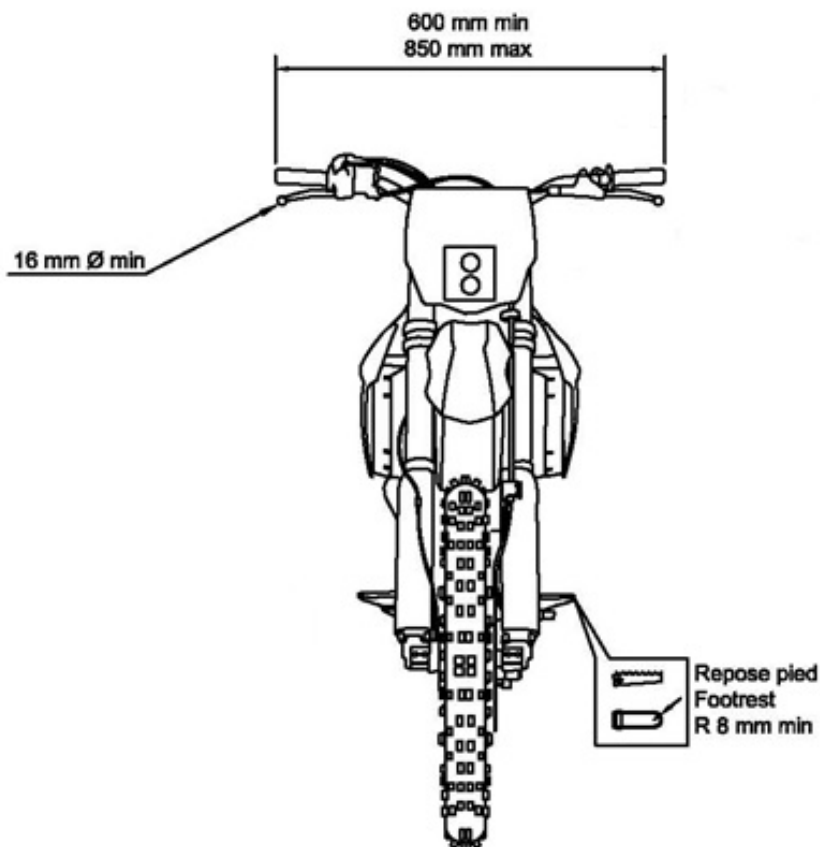

Figure 4

02.09 FOOTRESTS

Footrests must be solidly fixed or of a folding type but in this case must be fitted with a device which automatically returns them to the normal position, and an integral protection is to be provided at the end of the footrest which must have at least 8 [mm] radius (see Diagrams). The footrest teeth shall not be sharp. The height of the footrest teeth must be 10 [mm] maximum. (See Figure 4)

02.10 BRAKES

All motorcycles must have at least two efficient brakes (one on each wheel) operated independently and operating concentrically with the wheel.

These braking systems can be hydraulic and electric.

02.11 MUDGUARDS AND WHEEL PROTECTION

Motorcycles must be fitted with rounded mudguards.

02.11.01

Mudguards must project laterally beyond the tyre on each side.

02.11.02

The front mudguard covered area must respect the angle formed by one line drawn from the front edge of the mudguard to the centre of the wheel and one drawn horizontally through the centre of the wheel must be maximum 60°. (See Figure 5)

02.11.03

The rear mudguard covered area must respect the angle formed by two lines, one drawn from the rear edge of the mudguard to the centre of the wheel and one drawn horizontally through the centre of the wheel shall not exceed 70°. (See Figure 5)

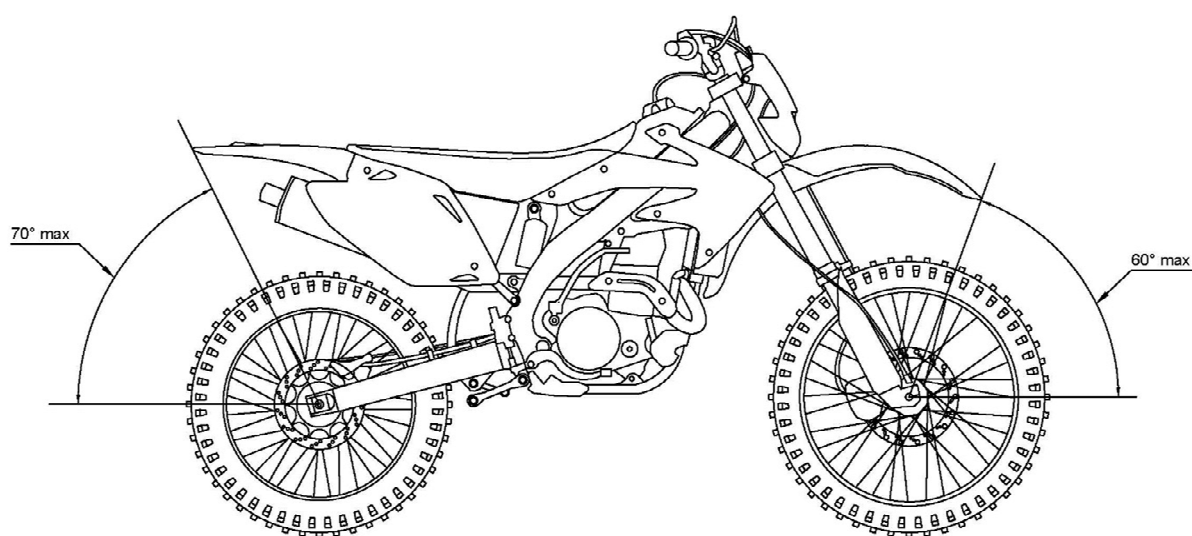

Figure 5

02.12 THROTTLE

A 'self-closing' full twist throttle for power control must be applied.

02.13 IGNITION CUT-OUT SWITCH

It is compulsory that all motorcycles be equipped with an operational cut-off switch, connected through a lanyard to the rider (max. length – 1[m]). Once the rider steps off the motorcycle, the lanyard must disconnect from the cut-off switch and **cut- out the traction cut the power to the engine.**

02.14 STREAMLINING

No type of streamlining is allowed.

Radiator covers (shields) must be made of flexible materials only (e. g. plastics).

02.15 SUSPENSION

Electronically controlled suspension systems must not be used.

02.16 WHEELS, RIMS, TYRES

Any modification to the rim or spokes of an integral wheel (cast, moulded, riveted) as supplied by the manufacturer, or of a traditional detachable rim other than for spokes, valve or security bolts, is prohibited.

The only exception made is for tyre retention screws, sometimes used to prevent tyre movement relative to the rim.

If the rim is modified for these purposes, bolts, screws, etc., must be fitted.

02.16.01 Restrictions for wheel (rim) dimensions

	Minimum wheel (rim) size	Maximum wheel (rim) size
Front wheel	19 [inch]	21 [inch]
Rear wheel	17 [inch]	19 [inch]

	GT	HIPERBIKE
Front wheel	19 [inch] to 21 [inch]	21 [inch]
Rear wheel	18 [inch] to 19 [inch]	18 [inch] to 19 [inch]

02.16.02 Tyres

Scoop or paddle (continuous radial rib) tyres and/or tyres with lugs having a height of over 19.5 [mm] are forbidden.

The tyre surface shall not be fitted with subsequently mounted elements such as anti-skid spikes, special chains, etc.

Bicycle tyres are strictly forbidden.

Speed category symbol (5.4): M (130 [Km/h]) or above

Load capacity index (5.5): 45 (165 [Kg]) or above.

Any marking on the tyre reporting "FIM" approved or similar is forbidden for new production dates (from 2018). FIM Quality Products are exempt of this rule.

02.17 ELECTRICAL

02.17.01 Electrical safety (Only Recommended)

It must be ensured that the components used cannot cause injury under any circumstances, either during normal operation or in foreseeable cases of malfunction. It must be ensured that the components used for protecting persons or objects can reliably fulfil their function for an appropriate length of time.

It must be ensured that a single point of failure of the electric system cannot cause electric shock hazardous to the life whatever the conditions (rains, etc.) in normal operation.

There must not be any exposed live conductive parts in the voltage class B (>60 V in DC / >30 V rms in AC)

The protection elements (carter, protective covers, etc.) against the direct contact could not be removed using without tools.

02.17.02 Electrical components (Only Recommended)

All parts of the electrical equipment must be protected to at least the equivalent of IP55D type protection (dust proof and splash proof). Exposed connectors/wires must be protected against abrasion in case of accident (side covers).

02.17.03 Power bus maximum voltage

The maximum allowed voltage in the main power bus is 420V DC or 300V AC (rms). A secondary power bus may be used to supply energy to the critical systems at a maximum voltage of 60V DC or 30V AC.

The secondary power cannot use to charge the main battery or to participate at the traction.

02.17.04 High voltage symbols

Symbols warning of 'HIGH VOLTAGE' must be displayed on or near the electrical equipment protective covers; all symbols must comprise a black flash of lightning inside a yellow triangle with a black border. The sides of the triangle must measure at least 80 [mm] (recommended), but may be larger if practical.



The cable or outer covering for voltage class B circuits not within enclosures or behind the barriers shall be marked in orange.

02.17.05 Insulation (Only Recommended)

Every part of the electrical equipment (class B) must be electrically insulated relative to all live components and system ground.

Wiring insulators can be required to be checked at any time by the FIM Technical Director/Chief Technical Steward. Double insulation will be required in high voltage or high current wires. Technical datasheets of the wires used will prevail under all circumstances.

For class B, the power circuit wire shielding must be connected to chassis ground. The isolation surveillance system will serve device for an isolation fault.

For class B, plus and minus wires from the battery must be insulated with respect to the chassis to withstand battery maximum voltage at least. The isolation resistance requirements of 100 Ohms/V for DC or 500 Ohms/V for AC allow body currents of 10 mA and 2 mA respectively.

For class B, an isolation surveillance system must be used to monitor the status of the isolation barrier between the class B system and the chassis.

All electrically conducting non-live parts must be connected with the system ground.

For class B, it is mandatory that all major conductive parts of the body are equipotential the motorcycle chassis with cable or conductive parts. The resistance $< 0,1$ Ohms between the exposed conductive parts which can be touched by a person simultaneously.

In cases where the voltage of the power circuit exceeds 60V DC or 30V AC (rms), the power circuit must be separated from the on-board circuit by an appropriate insulator.

Insulating material not having sufficient mechanical resistance, i.e. paint coating, enamel, oxides, fibre coatings (soaked or not) or insulating tapes are not accepted.

Electric cable and equipment must be protected against any risk of mechanical damage (stone, mechanical failure, ...) as well as any risk of fire and electrical shock.

Every part of the electric equipment, including wires and cables must have an appropriate insulation resistance between live components and chassis.

02.17.06 Power Indicator

There must be at least three clear visible indicators:

- ONE light or instruction message on the instruction panel/dashboard (located in the identified area, please see the diagram hereunder).



- TWO lights (like LED repeaters) (recommended) must be visible from 10 meters away positioned on the both sides of the motorcycle (located in the identified area, please see the diagram hereunder). These two sides indicators must be protected from any possible contact (rider, environment, etc.).

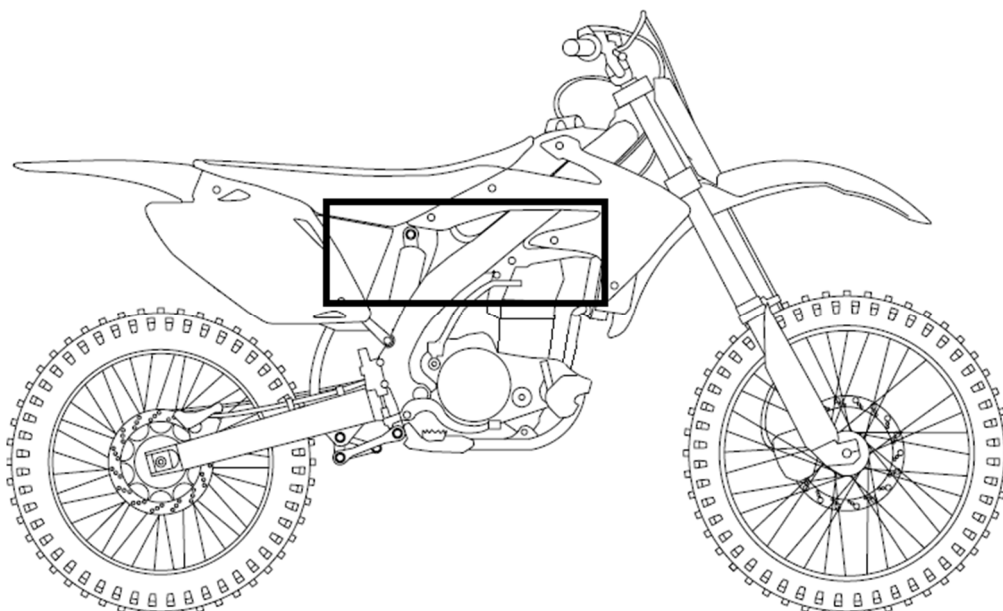

LED colours strategy: the indicators warn if the motorcycle is:

- ~~SAFE IN DRIVE MODE ON (Power ON and Drive mode ON): different than RED permanent lights (examples: GREEN, BLUE, YELLOW OR WHITE)~~
- ~~NOT SAFE: RED or NO LIGHT (in a hazardous state (insulation failure, etc.))~~

LED status	Prompt	Meaning
GREEN	LEDs are permanently on. Power ON, voltage > 60V DC and Drive mode is OFF	SAFE
GREEN BLINKING	LEDs are blinking. DRIVE MODE IS ON	SAFE
RED	LEDs are permanently on. In a hazardous state (insulation failure, etc.)	NOT SAFE
NO LIGHT	When LEDs are not visible but bike is switched on.	NOT SAFE

For the Class B only: The indicators must show when there is a voltage on the power circuit above 60 V in DC – for ready to move or interventions.

02.17.07 General circuit breaker – 'Emergency Stop'

The general circuit breaker must disconnect from the cut-off switch and discharge the main bus voltage below 60[V]. This system will be referred to as general circuit breaker or “Emergency stop”.

Low power accumulators provided for low voltage circuits, e.g. auxiliary circuits, do not have to be isolated by the general circuit breaker (Emergency Stop) provided that they are completely isolated from the main power accumulators.

The biker circuit breaker must be operated by the biker when seated. The biker circuit breaker must be separate from the general circuit breaker.

In case of an emergency stop, the general circuit breaker must isolate the plus and minus of the battery, not motor torque, enable the active discharge, isolate the auxiliary battery from the auxiliary circuit.

02.17.08 Fuses (over-current trip switches)

An over-current trip switch is a device which automatically interrupts the electrical current in which it is installed if the level of this current exceeds a defined limit value for a specific period of time.

Fuses must under no circumstance replace the general circuit breaker (Emergency Stop).

The fuses must be fitted inside the battery pack. The fuses will be used during the charge.

02.17.09 Capacitors (Only Recommended)

Voltage across capacitors belonging to the power circuit should fall below 60 volts within 5 seconds after the general circuit breaker is opened or the over current trips of the accumulator are blown. An active discharge could be used.

Capacitive couplings between class B potential and electric chassis are used for EMC reasons. ~~The manufacturer must provide to the FIM Technical Director the EMC self-certification (or external laboratory certification).~~

The energy caused by the discharge for the current DC shall be < 0,2 J.
For AC body currents cause by capacitive couplings when touching AC high voltage that the AC current shall not exceed 5 mA.

02.17.10 Motor cut-out switch(es)

All motorcycles must have a cut-out switch fitted to operate when the rider leaves the motorcycle. This cut-out system must **cut- out the traction** ~~stop the motor~~.

This ~~traction motor~~ cut-out switch must be operated by a lanyard of non-elastic string of adequate length and thickness. Once the rider steps off the motorcycle, the lanyard must disconnect from the cut-off switch and the engine. The lanyard must be fastened to the cut-out switch firmly in a way that it cannot be disconnected inadvertently but only when the rider leaves the motorcycle.

The cut-out switch cannot be taped, glued wired or fitted solidly in place.

02.17.11 Accumulator (storage battery) (Only Recommended)

The type, dimensions and weight of accumulator/s cannot be changed between official practices and race.

All on-board electrical equipment, unless consisting of items originally powered by dry batteries, small accumulators or their own solar cells, must receive its energy supply from the vehicle's official accumulators.

For the assistance operation, the battery must be capable of being isolated from the power circuit by at least two independent systems (relays, ...) and disconnection device. In case of relay failure, the electrical technician with appropriate PPE disconnects the battery.

The battery system must avoid the overvoltage.

A drop test is required (height of 1m then charge/discharge at 1C). The manufacturer must proceed to the drop test procedure (in 6 different impact points) and provide to the FIM Technical Director the self-certification form of this test.

The battery compartment must prevent the build-up of an ignitable gas/air, dust/air or hydrogen concentration inside the compartment. The hydrogen exhaust must not be excessive.

The BMS (Battery Manager System) must protect against the overvoltage, overtemperature and prevent thermal runaway, during overcharge or battery failure.

The BMS is a security system that detects internal defaults then can trigger the power reduction (charge or discharge) until the switch off.

IMPORTANT: As a condition of entry, a Material Data Safety Sheet must be supplied with the race entry for the machine, including all relevant details as to the accumulator chemistry, human and environmental hazards, handling and specific fire risks and precautions.

02.17.12 Charging the accumulator (Only Recommended)

Energy supply will be provided in the paddock at the times and locations determined by the race Organiser.

The charge is operated safe of the sun and rain, in the ventilated area.

Charging may only be done with the energy supply provided by the race Organiser. The charging system must be separate from the machine and comply with all electrical safety requirements including thermal overload trip, fusing and be equipped with an earth leakage protection breaker.

Charging must always be done with the control of the BMS.

The traction system is off during the charge or charge cable is plugged without power. No movement of the motorcycle during the charge (even if drive on is selected then no power).

The charger must be connected by the grid's earth to the motorcycle ground. The motorcycle traction system must be checked for ground faults before the charge start.

The charger must have a fuse to protect the charging cable.

02.17.13 Accumulator fastening (Only Recommended)

The accumulator must be installed securely inside the vehicle and be protected against short-circuits and leakage. The accumulator must be attached to the frame or chassis using metal clamps with an insulating covering (for Class B only).

The fixing method must be designed in such a way that neither the accumulator nor the fastening device itself nor its anchorage points can come loose, even when subjected to a crash. A solid partitioning bulkhead must separate the location of the accumulator from the rider.

Each accumulator box must provide its own cooling and/or venting system. In modular battery systems, a heat shield is strongly recommended between modules, by means of an adiabatic shield or intumescent.

The accumulator installation must ensure that in the event of accumulator cell leakage or explosion, the contents are kept away from the rider and do not interfere in any way with the rider's vision or the safe handling of the machine.

The battery shall be installed in the motorcycle in order to avoid the possibility inadvertent or unintentional detachment. The battery shall not be ejected when the motorcycle is tilted.

02.18 DATA RECORDING

The use of data recording devices is authorised.

Information must not be transmitted in any way to or from a moving motorcycle (telemetry is not allowed) except for compulsory devices contracted (by the FIM or the Promoter) for the Championship.

All machines must be equipped with an official transponder (data: battery voltage and battery current).

An official signalling device may be required on the machine.

Automatic lap timing devices must not disrupt any official time keeping methods and equipment.

02.19 NUMBER PLATES

Number plates must be made of flexible materials only (e.g. plastic). The shape of the front number plate is free and may be part of the general design of the motorcycle.

The plates curved not more than 50 [mm] out of a true plane must not be covered or bent.

The English form for numbers must be used. That is single vertical line for the "one" and a simple sloping line without a horizontal line for the "seven" (see Diagram O).

Reflecting numbers are forbidden.

The numbers must be clearly legible. In case of a dispute, the decision of the FIM Technical Director will be final.

One plate must be fixed to the front inclined not more than 30° towards the rear from the vertical plane. Holes can be perforated between the numbers on the number plate. However, under no circumstances must the actual numbers be perforated.

The following minimum dimensions must be respected on the front number plate:

- Height of the number 140 [mm]
- Width of each number 70 [mm]
- Width of the stroke 25 [mm]
- Space between two numbers 15 [mm]
- Space between the FIM logo and the number 10 [mm]

All other number plates or markings on a motorcycle liable to cause confusion with the number must be removed before the start of a competition.

03 EQUIPMENT AND PROTECTIVE CLOTHING DURING PRACTICE AND RACE

The FIM cannot be held liable for any injuries that a rider or passenger may sustain from the use of a specific item of equipment or protective clothing.

03.01 CLOTHING AND PROTECTORS

In general, it is recommended to use suit, trousers, long-sleeve shirts and undergarments made of textiles which are not fully constituted of nylon or spandex (e.g. Lycra, Elastan), in order to avoid degradation in case of abrasion (friction).

Back and chest protectors are mandatory.

Any modifications brought to the protectors remove the certification of the equipment and will not be accepted.

If the clothing and/or protectors listed below does not meet the technical requirements or is found to be defective, the Technical Steward must clearly mark in red (e.g. with a red dot) all international marks without destroying them and retain it until the end of the event. The rider must submit another clothing and/or protectors for approval by the Technical Steward. After an accident involving impact, the back and chest protector must be presented to the Technical Steward for examination.

It is compulsory that all protective devices are clearly marked with the relative norms and comply with the following standard:

- EN 1621-1, Level 2, for shoulders, elbows, hips and knees
- EN 1621-2, Level 1 or 2, for the back: CB (Central Back) and FB (Full Back)
- EN 1621-3, Level 1 or 2, for the chest

It is compulsory that all riders/passengers wear either suit or trousers, a long-sleeve shirt.

A functional airbag vest/system is highly recommended. The cervical collar is not compatible with the airbag and is therefore prohibited if fitted.

It is strongly recommended to wear shoulder, elbow and knee protectors as well.

03.02 FOOTWEAR

Footwear, in a good condition, made of leather or other materials having equivalent properties, shall be worn and have a minimum height of 300 [mm].

03.03 GLOVES

All disciplines riders/passengers shall wear gloves made of leather or other materials having equivalent properties.

03.04 EYE PROTECTION

Riders/passengers shall wear goggles (**in case of an off-road helmet**) or a **full closed visor (in case of a full face circuit racing helmet)**.

The use of glasses, helmet visors and 'tear offs' or 'roll offs' are also permitted. The material used for glasses, goggles and visors must be made of shatter-proof material. Helmet visors must not be an integral part of the helmet.

Eye protectors which cause visual disturbance (e.g. scratched) must not be used.

03.05 WEARING OF HELMETS

- It is compulsory for all participants taking part in practice and races to wear a protective helmet. The helmet must be properly fastened, be of a good fit, and be in good condition. The helmet must have a chin strap type 'retention system'.

- A protective lower face cover must be present and must be not detachable and not moveable.
- Helmets constructed with an outer shell made of more than one piece are not permitted (e.g. they must not contain any seam).
- A retention system with a strap and the double D ring closing system is recommended.
- All helmets must be marked with one of the official international standard marks mentioned in Art. 03.05.02. Any FMN approval marks do not substitute the official international standard marks.
- A helmet is made to provide protection. A helmet is not a platform to attach foreign objects.
- Long hair, whether of female or male riders, must not come out of the helmet. Long hair must be completely contained within the helmet or in a hair bun.

Failure to observe the above rules will entail exclusion.

03.05.01 Helmet Operative Instructions

Scrutineers, under the supervision of the Chief Technical Steward, may check prior to practice and the races that all helmets meet the technical requirements.

If a helmet does not meet the technical requirements or is found to be defective, the Technical Steward must clearly mark in red (e.g. with a red dot) all international marks without destroying them and retain the helmet until the end of the event. The rider must submit another helmet for approval by the Technical Steward. After an accident involving impact, the helmet must be presented to the Technical Steward for examination.

All helmets must be intact and no alteration must have been made to their construction.

The Chief Technical Steward/Technical Steward may ask a rider for the following checks before the rider is permitted to take part in practice or race:

- That the helmet fits well on the rider's head.
- That it is not possible to slip the retention system over the chin, when fully fastened.
- That it is not possible to pull the helmet over the rider's head by pulling it from the back of the helmet.

03.05.02 Recognised International Helmet Approval Marks

Helmets must conform to one of the recognised international standards:

FIM	FRHPhe-01 (till 31.12.2025) or FRHPhe-02
EUROPE	ECE 22-05 or ECE 22-06 (only "P" type (Full face))
JAPAN	JIS T 8133:2015 (only "Type 2 Full face")
USA	SNELL M 2015 or SNELL M 2020D or SNELL M 2020R or SNELL 2025R or SNELL 2025D

Examples of labels are reported below:

EUROPE	
JAPAN	
USA	

As from 01/01/2024, FIM homologated helmets according to the FRHPhe-02 (with a valid FIM homologated label) are strongly recommended, and will be mandatory as from 01/01/2026. All the other standards will be forbidden.

A list of FIM Homologated helmets will be available on www.frhp.org

<p>FHHPhe-01 (FIM)</p>	 
<p>FRHPhe-02 (FIM)</p>	

03.06 BADGE OF THE FIM

Under certain circumstances the FIM may permit the use of the FIM badge on certain equipment in order to show that the latter conforms to the standards laid down by the FIM. When this authorisation is granted and provided the equipment on which it appears is in good condition, the badge is then the guarantee of the conformity with the standard set by the FIM.

03.07 NUMBER SASHES (BIBS)

Starting numbers to be worn on sashes (bibs) or printed on the riders' jersey must be conforming to the following:

The colour of the number must be in strong contrast with the colour of the background. The number may be outlined. The colour of the outlining must be in contrast to the background color as well as the number colour (ex: a white jersey with orange numbers could use a black outline).

Distance between the numbers: 15 [mm].

Height of number: minimum 200 [mm].

Width of number: minimum 100 [mm] for one-digit numbers
minimum 200 [mm] for two-digit numbers
minimum 250 [mm] for three-digit numbers.

Width of stroke: 30 [mm].

Minimum free space around the number without publicity: 50 [mm].

Bibs if manufactured from plastic material must be perforated to provide adequate ventilation.

Starting numbers used by riders on number sashes or tee-shirts must be in compliance with the starting number of the race in question. Furthermore the numbers must be worn during the practices as well as during the races.

03.08 TEAM STAFF EQUIPMENT OPERATED ON ELECTRIC CIRCUIT OF THE MOTORCYCLE

Equipment required to be used and to be familiar with :

- Gloves : CEI 60903-2002 or CEI 60903-2003
- Robust shoes with insulated soles
- Safety glasses (helmet or visor)
- CO2 fire extinguisher for HV system (min. 1 with a valid certification) - optional
- F500 extinguisher for Lithium-Ion battery (min. 1 with a valid certification)
- Emergency hook : CEI 61235 (provided by the team)

04 TECHNICAL VERIFICATIONS

As a condition of entry, all safety items on-board the motorcycle must be precisely described and presented at the Technical Verifications.

The FIM Technical Director/Chief Technical Steward shall check both the machine and the rider for compliance with the technical specifications, as well as the employment of good engineering construction practice, and the presence of adequate electrical insulation and weatherproofing. ~~The motorcycle model must be compliant with the EMC regulations ECE-R10.~~

Damaged machines must be returned to the technical control area for examination after race or practice. In such circumstances it is the responsibility of the competitor to ensure both his machine and clothing have been rechecked and approved before further use in the event. If stickers/marks are used, a new sticker/mark must be in place.

It is the responsibility of the rider to ensure that a machine used in competition is electric, mechanically and structurally in a safe condition.

In case of a dispute, the decision of the FIM Technical Director will be final.

04.01 CONFORMITY

It is the duty of each competitor to show the Technical Stewards of the meeting that his vehicle fully complies with these rules and the rules governing the meeting, in their entirety at all times.

04.02 PREPARATION

- Prior to the Technical Verifications, it should be decided who is doing what and note decisions. "Efficiency" must be the watchword. Always keep cheerful and remember the reasons for scrutineering: SAFETY AND FAIRNESS.
- Before the START of the competition, a closed and guarded area (closed parc/parc-fermé) shall be prepared.
- Inspection must take place under cover with a large enough area.
- Inspection area must be supplied with the necessary equipment, including tables, chairs, electric light and power outlet.
- Weighing apparatus must be accurate, practical and have a minimum resolution of 100g. Weighing scales must have been certified by a National Institute within the period of 24 months before the event. Certified master weights and their certificate must be available for verifying.
- The necessary tools are listed below:
 - ✓ Revolution meter
 - ✓ Slide calliper
 - ✓ Depth gauge
 - ✓ Steel measuring tape
 - ✓ Seals
 - Weighing apparatus and set of reference weights (to be furnished by the Organiser)
 - ✓ Tools for measuring the battery capacity
 - ✓ Coloured paints and stickers for marking parts
 - ✓ Heat resistant stickers or paint for marking the silencer (and solvent)
 - ✓ Magnet
 - ✓ Adequate fuel sample bottles
 - ✓ PC with CD Drive + updated operating system
 - ✓ Printer, etc. are recommended
 - ✓ Calculator
- The necessary documents are listed below:
 - ✓ Supplementary Regulations
 - ✓ FIM Technical Rules - current year
 - ✓ FIM Rules of the discipline concerned
 - ✓ FIM Sporting Code
 - ✓ Homologation papers (if applicable)

- ✓ Writing material
 - ✓ Technical Verifications forms
- All necessary measures and administrative equipment should be in place at least 1/2 hour before the start of the Technical Verifications is due to open (time in Supplementary Regulations).

04.03 VERIFICATIONS

- The Technical Verifications before the official practice and before the race should last at least one hour, after the race last at least 30 min.
- The Technical Verifications must be carried out in conformity with the procedure and times fixed in the CEB Rules and the Supplementary Regulations of the event.
- An example of minimum verifications that shall be performed is given below:

INITIAL TECHNICAL VERIFICATIONS	CHECK	MARKING
Make + model	<input type="checkbox"/>	
Frame	<input type="checkbox"/>	<input type="checkbox"/>
Cut-off switch (lanyard)	<input type="checkbox"/>	
Self-closing throttle	<input type="checkbox"/>	
Brakes (front and rear)	<input type="checkbox"/>	
LED colours strategy according to motorcycle state	<input type="checkbox"/>	
Class B electrical parts marking (yellow triangle)	<input type="checkbox"/>	
Class B wires in direct access (in orange colour)	<input type="checkbox"/>	
Battery Output voltage	<input type="checkbox"/>	
Weight + ballast	<input type="checkbox"/>	
Battery Fastening	<input type="checkbox"/>	<input type="checkbox"/>
Battery drop test certificate	<input type="checkbox"/>	
Guard for the countershaft sprocket and rear sprocket	<input type="checkbox"/>	
Handlebar ends + protection + levers	<input type="checkbox"/>	
Front/rear brake disc protection	<input type="checkbox"/>	
Helmet(s)	<input type="checkbox"/>	<input type="checkbox"/>
Protective clothing (boots, gloves, suits, etc)	<input type="checkbox"/>	<input type="checkbox"/>
Environmental mat	<input type="checkbox"/>	

- An overall inspection of the motorcycle must be carried out in conformity with the FIM rules. On accepted motorcycles a sticker or paint will be applied on the front of the main frame.
- The Technical Verifications will only be carried out when the Technical Verifications form of the motorcycle has been presented by the rider or his mechanic.
- Each team can present and use four electric motorcycles that must successfully pass the technical scrutineering.

- Each battery (or battery cover if no direct access battery) and frame will be marked by the FIM & FMNR Technical crew. No extra battery will be allowed to be used during the competition.
- For the Technical Verifications taking place after the race, it shall be ensured that the selected machines used during the race go directly to the Closed Parc (Parc Fermé).

04.04 FMNR CHIEF TECHNICAL STEWARD AND TECHNICAL STEWARDS

- The Chief Technical Steward must be in attendance at an event one hour before the Technical Verifications are due to begin. He must inform the Clerk of the Course/FIM Race Director and FIM Technical Director, if present, of his arrival.
- The Chief Technical Steward must ensure that all technical stewards appointed for the event carry out their duties in a proper manner. The Chief Technical Steward shall appoint the technical stewards to individual posts for the race, practices and final control.
- Scrutineers can have different tasks, but the team of scrutineers must have a minimum of five persons. The FMNR Chief Technical Steward must be a holder of an FIM SENIOR Technical Stewards Licence and at least one Technical Steward must hold a FIM Technical Stewards Licence. A minimum number of scrutineers is required according to the following:
 - Checking of documentation: one person
 - Machine inspection: two persons
 - Helmet and clothing: two persons
- Ten minutes before each start and in the waiting area, the technical steward will carry out the control of the seals and the riders' equipment.
- During the event the technical steward will control the seals and the riders' equipment in the repair zone. He must follow the work being carried out on the machines in order to ensure that no motorcycle becomes a source of danger.
- Immediately after the last race the first three motorcycles will be placed in a closed park for technical control. The machines must remain in the closed park for 30 minutes after the arrival of the winner, in case of a protest or should further examination be required.

Competitors must retrieve their machines within 30 minutes after the opening of the closed park area, except for the machines which are chosen for disassembly.

After this time limit, the closed park officials will no longer be responsible for the machines left behind.
- After the technical control has been completed the Chief Technical Steward will submit to the Clerk of the Course/FIM Race Director a list stating the names of the accepted riders and machines and weights of machines.

- If a motorcycle is involved in an accident, the Technical Steward must check the machine to ensure that no defect of a serious nature has occurred. However, it is the responsibility of the rider to present his machine for this re-examination together with the helmet and clothing worn.
- If the helmet is clearly defective, the Technical Steward must retain it. The organiser must send this helmet, together with the accident and medical report (and pictures and video, if available) to the Federation of the rider. If there are head injuries stated in the medical report, the helmet then must be sent to a neutral institute for examination.
- The Chief Technical Steward has the right to look/ inspect any part of the motorcycle at any time of the event.
- All technical stewards shall be well informed and shall make sure their FMN has supplied them with all technical "updates" that may have been issued subsequent to the printing of the Technical Rules books.

04.05 FIM TECHNICAL DIRECTOR

- The FIM Technical Director is appointed by the Director of the FIM International Technical Commission in consultation with the Director of the FIM E-bike Commission.
- The FIM Technical Director is not responsible for the technical verifications but will ensure that they are carried out in accordance with the FIM Technical Rules.
- The FIM Technical Director works in cooperation with the FIM Race Director and the FIM Delegate.
- The authority and duties of the FIM Technical Director include but are not limited to (Please, also refer to the FIM Technical Rules):
 - a) The FIM Technical Director will report any concerns or deficiencies relating to the technical verifications to the FIM Race Director and FIM Delegate and present proposals to resolve such concerns.
 - b) The FIM Technical Director is the final arbiter in relation to technical issues at the event.
 - c) The FIM Technical Director will examine with the Chief Technical Steward the motorcycle(s) and the protective equipment of any rider(s) involved in serious or fatal accidents and present a written report to the FIM Delegate.
 - d) The FIM Technical Director will attend all meetings of the Race Direction, but without voting rights.

04.06 RIDER AND/OR MECHANIC

- The rider and/or the mechanic and/or the Team Manager must attend at least once the Technical Verifications with the (rider's) machine within the time limits stated in the Supplementary Regulations.
- On request of the technical steward, the rider must present himself to the Technical Verifications.
- The maximum number of persons present at the technical verification will be the rider and/or the mechanic and/or the Team Manager.
- A rider remains at all times responsible that his machine and his personal protective gear are in conformity with the FIM Technical Rules for E-bike motorcycles.
- The rider and/or the mechanic and/or the Team Manager must present a clean motorcycle in conformity to the FIM rules and a duly filled in and confirmed Technical Verifications form.
- A rider and/or the mechanic and/or the Team Manager must present one motorcycle for technical inspection under the rider's name and number. As for the second motorcycle, there are two possibilities:
 - 1) A rider and/or the mechanic and/or the Team Manager can present a second motorcycle for technical inspection under his name and number.
 - 2) A team or a group of riders/mechanics/Team Managers can present a second motorcycle for technical inspection. It can then be used by several riders, on condition that the motorcycle has been marked under each rider's name and number. In this case, the team presenting the motorcycle must indicate at the moment of technical inspection the names and numbers of the riders eligible to use it.
- The rider may change the motorcycle between races. The final choice must be made a minimum of 10 minutes before the start of each race.
- The rider and/or the mechanic and/or the Team Manager must present the rider's protective wear (equipment), e.g. helmet and bib with prescribed starting number.
- Any rider failing to report as required by the provisions below may be excluded from the meeting.
- The Clerk of the Course/FIM Race Director may prohibit any person who does not comply with the rules, or any rider who could be a danger to other participants or to spectators, from taking part in the competitions.

04.07 DANGEROUS MACHINES

If, during practice or the race, a Technical Steward finds that a machine is defective and might constitute a danger to other riders, he must immediately notify the Clerk of the Course/FIM Race Director or his deputy. It is their duty to exclude such a machine either from the practice or from the race itself.



**FEDERATION INTERNATIONALE
DE MOTOCYCLISME**

FIM-MOTO.COM

ROUTE DE SUISSE 11 | 1295 MIES | SWITZERLAND

ceb@fim.ch