



FÉDÉRATION INTERNATIONALE  
DE MOTOCYCLISME

TECHNICAL RULES  
BAJAS

2023

*RÈGLEMENTS TECHNIQUES  
BAJAS*



# **Technical Rules Bajas**

# **2023**

# **Règlements Techniques Rallyes Tout-Terrain**

<b>YEAR 2022</b>		
<b>Version</b>	<b>Applicable as from</b>	<b>Modified paragraphs</b>
0	01.01.2023	59.01, 59.11, 01.70

## Table of contents

01.01	INTRODUCTION.....	4
01.03	FREEDOM OF CONSTRUCTION .....	4
01.05	CATEGORIES AND GROUPS OF MOTORCYCLES .....	4
01.07	CLASSES .....	5
01.11	MEASUREMENT OF CAPACITY .....	7
01.17	SUPERCHARGING .....	8
01.18	TELEMETRY.....	8
01.19	MOTORCYCLE WEIGHTS .....	8
01.21	DESIGNATION OF MAKE .....	8
01.23	DEFINITION OF A PROTOTYPE .....	8
01.25	GENERAL SPECIFICATIONS .....	8
01.26	DEFINITION OF A FRAME OF A SOLO MOTORCYCLE .....	10
01.27	STARTING DEVICES .....	10
01.29	OPEN TRANSMISSION GUARDS .....	10
01.31	EXHAUST PIPES.....	10
01.33	HANDLEBARS.....	11
01.35	CONTROL LEVERS .....	12
01.37	THROTTLE CONTROLS .....	13
01.39	FOOTRESTS .....	13
01.41	BRAKES .....	13
01.43	MUDGUARDS AND WHEEL PROTECTION .....	13
01.45	STREAMLINING .....	14
01.47	WHEELS, RIMS, AND TYRES.....	14
01.55	NUMBER PLATES.....	16
01.56	LIGHTING, WARNING EQUIPMENT AND SPEEDOMETERS .....	17
01.58	ADDITIONAL SPECIFICATIONS FOR 450CC .....	17
01.59	ADDITIONAL* SPECIFICATIONS FOR QUADS .....	18
01.65	EQUIPMENT AND PROTECTIVE CLOTHING DURING PRACTICE AND RACE.....	23
01.67	WEARING OF HELMETS .....	24
01.69	HELMET OPERATIVE INSTRUCTIONS .....	25
01.70	RECOGNISED HELMET APPROVAL MARKS.....	26
01.75	BADGE OF THE FIM .....	27
01.76	NUMBER SASHES (BIBS).....	27
01.77	TECHNICAL VERIFICATIONS .....	27
01.78	DANGEROUS MACHINES .....	33
01.79	SOUND CONTROL.....	33

## DIAGRAMS

Any references to the male gender in this document are made solely for the purpose of simplicity, and refer also to the female gender except when the context requires otherwise.

## **01.01 INTRODUCTION**

The term motorcycle covers all vehicles having, in principle, less than four wheels, propelled by an engine and designed essentially for the carriage of one or more persons of which one is the rider of the vehicle. The wheels must normally be in contact with the ground except momentarily or in certain exceptional circumstances. Furthermore, in order to traverse certain surfaces one or all of the wheels can be replaced with skis, rollers or chains.

## **01.03 FREEDOM OF CONSTRUCTION**

A motorcycle must conform to the requirements of the FIM regulations, to the Supplementary Regulations, as well as to a number of specific conditions that the FIM may require for certain competitions. No restriction is placed on the make, construction or type of motorcycle used.

All solo motorcycles (Group A) must be constructed in such a way that they are entirely controlled by a rider. Motorcycles with Sidecars (Group B) must be constructed to carry a passenger.

## **01.05 CATEGORIES AND GROUPS OF MOTORCYCLES**

Motorcycles are divided into categories which must be observed for all meetings and world record attempts.

In principle, it is forbidden for different categories, groups and classes to compete in the same race, unless the Supplementary Regulations state otherwise.

### **Category I**

Motorcycles propelled by the action of one wheel in contact with the ground.

### **Category II**

Special vehicles propelled by the action of one or two wheels in contact with the ground but which are not covered by the conditions of Category I.

#### **Group A1 - Solo Motorcycles**

2-wheel vehicles making only one track on the ground.

### **Group B1**

Vehicles with three wheels, making two tracks on the ground, consisting of a motorcycle making one track and a sidecar for a passenger making the other track.

### **Group B2**

Vehicles with three wheels, making two or three tracks on the ground in the direction of forward travel, with a permanently attached Sidecar forming a complete integral unit.

If three tracks are made, the centre-lines of the two tracks made by the motorcycle wheels must not be more than 75 [mm] apart. A track is determined by the longitudinal centre-line of each of the vehicle's wheels in the direction of forward travel.

### **Category III**

Vehicles propelled by the action of multiple driving wheels in contact with the ground in only one direction.

Group C - Special 2 wheel driven motorcycles

Group D - Special 3 wheel, 2 wheel driven motorcycles

Group E - Snowmobiles

Group F - Sprinters and Dragsters

Group G - Quad racers (propelled by the action of two wheels)

Group H - Quad racers (propelled by the action of four wheels)

### **01.07 CLASSES**

Groups are again separated into classes according to cylinder capacities as detailed below. Generally, these classes must be observed for all meetings.

See also Arts. 80.7.1 of the 2023 FIM Bajas World Championship Regulations, for details.

## Category I

### Group A1 - Solo Motorcycles

Class (cc)	over (cc)	up to(cc)
50	-	50
80	50	85
100	85	100
125	100	125
175	125	175
250	175	250
450	250	450
500	450	500
750	500	750
1000	750	1000
1300	1000	1300

### Groups B1, B2 - Sidecars

Same as groups A1 and A2 over 175 cc.

## Category II

Same classes as Category I, Group A1.

## Category III

Same classes as Category I, Group A1.

*\*Please refer to Art. 82.7.1 Categories, Groups, Classes and Trophy of the 2023 FIM Bajas World Cup Regulations.  
(extract hereunder)*

All motorcycles will be according to Category I, Group A1 and Category II, Group C (Art. 01.07), with the following specifications:

### 07.01 Categories/Groups/Classes are as follows:

- Category 1: Motorcycle (Up to 450cc)
- Category 2: Quad
- Category 3: SSV World Cup (Up to 1050cc) – (Art. 01.60)

The following Classes will be implemented in Category 1 and 2\*:

- Class 1: Women World Cup
- Class 2: Junior World Cup
- Class 3: Veteran Trophy

## 01.11 MEASUREMENT OF CAPACITY

### 11.11 Reciprocating movement engine, "Otto" Cycle

The capacity of each engine cylinder is calculated by the geometric formula which gives the volume of a cylinder; the diameter is represented by the bore, and the height by the space swept by the piston from its highest to lowest point:

$$\text{Capacity} = \frac{D^2 \times 3.1416 \times C}{4}$$

where D = bore  
and C = stroke

When a cylinder bore is not circular the cross sectional area must be determined by a suitable geometrical method or calculation, then multiplied by the stroke to determine capacity.

When measuring, a tolerance of 1/10 [mm] is permitted in the bore. If with this tolerance the capacity limit is exceeded for the class in question, a further measurement should be taken with the engine cold, to 1/100 [mm] limits.

### 11.13 Rotary engines

The capacity of an engine which determines the class in which the motorcycle shall compete in a meeting shall be calculated by:

$$\text{Capacity} = \frac{2 \times V}{N}$$

where V = total capacity of all the chambers comprising the engine  
and N = number of turns of the motor necessary to complete one cycle in a chamber.

This engine is classified as a 4-stroke.

### 11.15 Wankel system

For Wankel system engines with a triangular piston, the capacity is given by the formula:

$$\text{Capacity} = 2 \times V \times D$$

where V = capacity of a single chamber  
and D = number of rotors

This engine is classified as a 4-stroke.



## **01.17 SUPERCHARGING**

Supercharging by means of a device of any kind is forbidden in all meetings.

An engine whether 2-stroke or 4-stroke coming within any one of the recognised classes (determined by the capacity of the working cylinder) shall not be considered as supercharged when in respect of one engine cycle, the total capacity measured geometrically, of the fuel charging device or devices, including the capacity of the working cylinder (if used for injecting the fuel), does not exceed the maximum capacity of the class in question.

## **01.18 TELEMETRY**

Information must not be transmitted in any way to or from a moving motorcycle.

An official signalling device may be required on the machine.

Automatic lap timing devices are not considered as “telemetry”.

Automatic lap timing devices must not disrupt any official time keeping methods and equipment.

## **01.19 MOTORCYCLE WEIGHTS**

At present, there are no minimum weight limits for motorcycles.

## **01.21 DESIGNATION OF MAKE**

When two manufacturers are involved in the construction of a motorcycle the name of both must appear on the machine as follows:

- The name of the chassis manufacturer
- The name of the engine manufacturer

## **01.23 DEFINITION OF A PROTOTYPE**

A prototype motorcycle is a vehicle which must conform to the safety requirements as required by the FIM Sporting Code and Appendices applicable to the type of competition for which it is to be used.

## **01.25 GENERAL SPECIFICATIONS**

The following specifications apply to all vehicles of the groups indicated and to all types of competitions except where otherwise stated in the corresponding section of the FIM Sporting Code.

They should also be applied to all national competitions unless the FMNR (National Motorcycling Federation) has otherwise directed.

Further specifications for some competitions may also be required and these will be detailed in either the appropriate FIM Appendix or in the Supplementary Regulations for the competition in question.

All vehicles from the 450cc and Quad categories must conform in all respects to the 1968 Vienna Convention, even if the country in which the machine was manufactured is not a signatory to that Convention, and be registered for road use.

These vehicles are based on series production motorcycles, which can be modified and/or equipped for off-road competition.

The main parts: frame, engine (cylinder, cylinder head and crankcase) and swing-arm (this latter only for 450cc) used must be a standard component, and must be freely available to the public. These main parts, with the exception of the crankcase, may be modified but must fulfil the FIM Bajas Technical Rules.

Concerning material verification, in case of doubt, a sample or the part in question shall be taken and analysed at a Material Testing laboratory.

#### **25.01 Use of titanium**

The use of titanium in the construction of the frame, the front forks (referred only to structural parts: legs, tubes, etc), the handlebars, the swinging arms, the swinging arm spindles and the wheel spindles is forbidden.

The use of light alloys for wheel spindles is also forbidden.

The use of titanium alloy nuts and bolts is allowed.

#### **25.03 Carbon fibre**

The use of carbon fibre reinforced materials is authorised (with the exception of handlebars and wheel rims).

#### **25.04 Ceramic materials**

The use of ceramic parts is forbidden.

#### **25.05 Other equipment**

No signal of any kind may pass between a moving motorcycle and any person, including radio and Bluetooth communication. The exception is for the signal from the time keeping transponder, the tracking system as provided by the Organiser, automatic lap timing devices or approved on-board cameras (with prior written approval from the Championship Promoter/Organiser, which cannot be granted for helmet mounted cameras).

## **25.06 Number of cylinders**

The number of cylinders in an engine is determined by the number of combustion chambers.

## **25.07**

If separate combustion spaces are used they must be connected by an unrestricted passage of minimum cross sectional area at least 50% of the total inlet port area.

## **01.26 DEFINITION OF A FRAME OF A SOLO MOTORCYCLE**

The structure or structures used to join any steering mechanism at the front of the machine to the engine/gear box unit and to all components of the rear suspension.

## **26.01**

Every motorcycle in the 'parc-fermé' must be equipped with a side-stand. The side-stand must be fitted, either on the frame or on the swing arm.

## **01.27 STARTING DEVICES**

Starting devices for the engine are compulsory.

## **01.29 OPEN TRANSMISSION GUARDS**

### **29.01**

A guard must be fitted to the countershaft sprocket.

### **29.02**

A chain guard must be fitted in such a way to prevent trapping between the lower chain run and the final driven sprocket at the rear wheel.

## **01.31 EXHAUST PIPES**

Exhaust pipes and silencers must fulfil all the requirements concerning sound control (see also Art. 01.79).

### **31.01**

The axis of the silencer end must be parallel (tolerance 15°) to the two principal longitudinal planes of the vehicle. The extremity of the silencer must not pass the vertical tangent of the rear tyre.

**31.02**

The edge of the silencer shall not be dangerous in case of accidental contact with the riders or helpers. In case of quads, the exhaust pipe of the silencer must be protected by a rounded edge of minimum 4 [mm].

**31.03**

Exhaust fumes must be discharged towards the rear but not in such a manner as to raise dust, foul the tyres or brakes, or inconvenience the passenger (in the case of sidecars), or any other rider.

**31.04**

On a Sidecar machine the exhaust must discharge horizontally and towards the rear, at a maximum angle of 30° to the axis of the machine.

**31.05**

Any NON-ORIGINAL valve systems installed on the exhaust system with a view to influencing (or modifying) the sound level meter test is forbidden. Only exhaust valve systems (e.g. Exup) provided by the manufacturer on the manifold are authorised. The setting is free.

**01.33 HANDLEBARS**

**33.01**

The width of handlebars must be not less than 600 [mm] and not more than 850 [mm]. (see Figure 1)

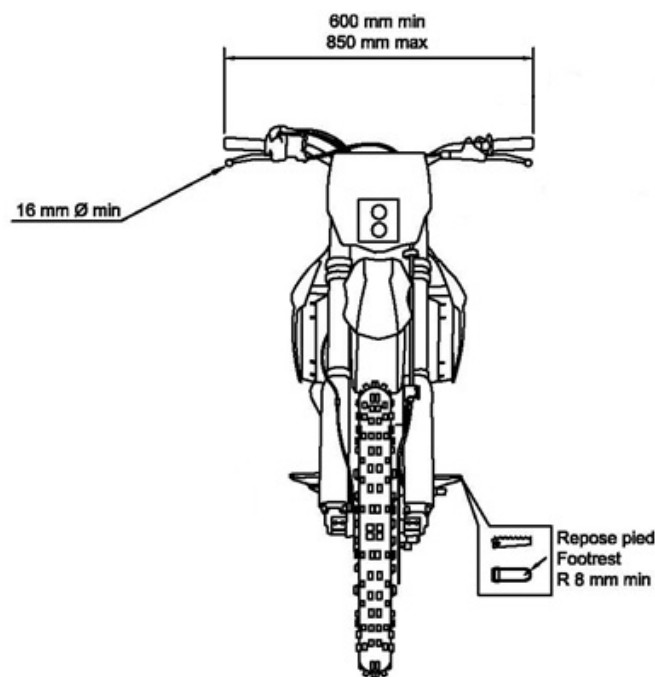

Figure 1

**33.02**

The handlebars must be equipped with a protection pad on the cross bar. Handlebars without a cross member must be equipped with a protection pad located in the middle of the handlebars, covering widely the handlebars clamps.

**33.03**

Handlebar clamps must be very carefully radiused and engineered so as to avoid any fracture points in the handlebar.

**33.04**

Exposed handlebar ends must be plugged with a solid material or rubber covered.

**33.06**

When hand protectors are used, these must be made of a shatter-resistant material and have a permanent opening for the hand.

**33.07**

Handlebars made of composite materials are not authorised.

**33.08**

Repair by welding of light alloy handlebars is prohibited.

**33.09**

Solid stops (when on full-lock, other than steering dampers) must be fitted. These must ensure a minimum clearance of 30 [mm] between the handlebar with levers and the tank to prevent trapping the rider's fingers.

**01.35 CONTROL LEVERS****35.01**

All handlebar levers (clutch, brake, etc.) must be in principle ball ended (diameter of this ball to be at least 16 [mm]). This ball can also be flattened, but in any case, the edges must be rounded (minimum thickness of this flattened part 14 [mm]). These ends must be permanently fixed and form an integral part of the lever. If the gear lever consists of a tube, then its edge must be rounded.

**35.03**

Each control lever (hand and foot levers) must be mounted on an independent pivot.

**35.04**

The brake lever if pivoted on the footrest axis must work under all circumstances, such as the footrest being bent or deformed.

**01.37        THROTTLE CONTROLS****37.01**

Throttle controls must be self-closing when not held by the hand. All air intakes into the cylinder must pass through the throttle body. No other means allowing ambient air into the inlet track of the cylinder head are allowed.

**37.03**

Solo motorcycles must be equipped with a functional ignition kill switch or button mounted on either right or left side of handlebar (within reach of the hand while on the hand grips), that cut the power to the engine.

Quads must be equipped with a safety ignition cut-out switch which must be permanently attached to the rider right wrist by a non-elastic, spiral cable, as short as possible.

**01.39        FOOTRESTS**

Footrests must be solidly fixed or of a folding type but in this case must be fitted with a device which automatically returns them to the normal position, and an integral protection is to be provided at the end of the footrest which must have at least 8 [mm] radius (see Figure 1). The footrest teeth shall not be sharp. The height of the footrest teeth must be 10 [mm] maximum.

**01.41        BRAKES****41.01**

All motorcycles must have at least 2 efficient brakes (one on each wheel, front and rear) operated independently and operating concentrically with the wheel.

**41.02**

Vehicles in Group B must be fitted with at least 2 efficient brakes operating on at least 2 of the wheels and be operated independently.

**01.43        MUDGUARDS AND WHEEL PROTECTION**

Motorcycles must be fitted with mudguards.

**43.01**

Mudguards must project laterally beyond the tyre on each side.

**43.02**

The front mudguard must cover the angle formed by one line drawn from the front edge of the mudguard to the centre of the wheel and one drawn horizontally through the centre of the wheel must be maximum 60°.

**43.03**

The rear mudguard must cover the angle formed by two lines, one drawn from the rear edge of the mudguard to the centre of the wheel and one drawn horizontally through the centre of the wheel shall not exceed 70°. (See Figure 2)

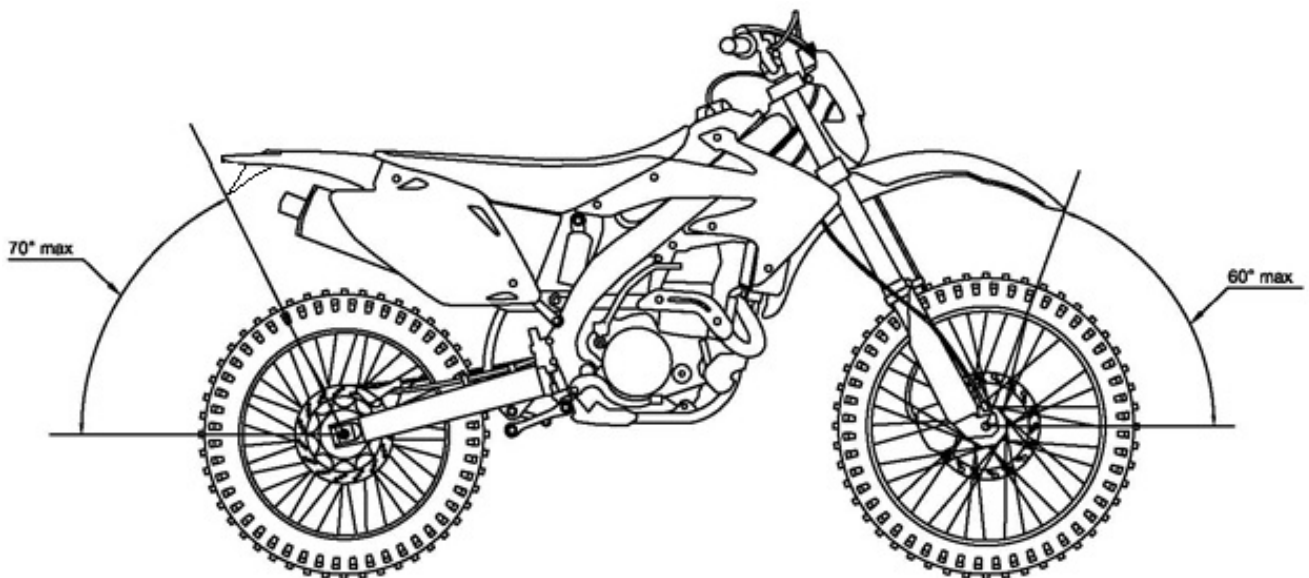

Figure 2

**01.45 STREAMLINING**

A 'full' fairing or 'complete' bodywork is not allowed.

Radiator covers (shields) must be made of flexible materials only (e.g. plastics).

**01.47 WHEELS, RIMS, AND TYRES****47.01**

All tyres will be measured mounted on the rim at a pressure of 1 [kg/sq.cm] (14 [lb./sq.in]); measurements are taken at a tyre section plane with a 90° angle with the ground plane.

**47.02**

Any modification to the rim or spokes of an integral wheel (cast, moulded, riveted) as supplied by the manufacturer (other than for rims with spokes, or valve and security

bolts) is prohibited, except for tyre retention screws sometimes used to prevent the tyre movement relative to the rim. If the rim is modified for these purposes, bolts, screws, etc., must be fitted.

#### **47.03**

The front and rear tyre dimensions are free with reference to diameter and width.

#### **47.04**

Tyres with metal studs, spikes, chains or any other anti-skid devices are not permitted. Scoop or paddle tyres (continuous radial rib) are forbidden.

#### **47.05**

Only tyres normally available from commercial or retail sources are authorised.

Modifying the tyre is not authorised. It is forbidden to treat tyres with chemicals, cut or groove them, use tyre warmers or any other means which may alter the shape, minimum Shore hardness, construction or other characteristics.

The tyres shall appear on the tyre manufacturers range catalogue or tyre specification lists available to the general public.

They shall be approved according to UN Vehicle Regulation 75 Rev. 2 (2010) with the following specific features:

- Category of use (5.2): it shall be "snow" or "special" or "All terrain"
- Speed category symbol (5.4): M (130 Km/h) or above
- Load capacity index (5.5): 45 (165 Kg) or above.

It is recommended that the tyres be used according to the European Tyre and Rim Technical Organisation (ETRTO) guidelines.

The E approval mark and number as defined by the UN Vehicle Regulation R75 must be present on both the front and rear tyre sidewalls.

The DOT approval mark is also accepted.

Any marking on the tyre reporting "FIM" approved or similar is forbidden for new production dates (from 2018). FIM Quality Products are exempt of this rule.

#### **47.06**

The tread pattern specifications of the rear tyre are free. However, Art. 47.05 applies in full.

#### **47.07**

The number of tyres is limited to one set (front(s) and rear(s)) per race day. When the day is composed of several stages, the tyres could be marked by the FIM Technical Director and/or his appointed crew.



**01.55 NUMBER PLATES**

Number plates are required for Bajas.

The Organiser shall provide each rider with a set of identification plates comprising 1 front plate and 2 side plates called number plates. The exact sizes and positions of these number plates will be explained in the SR.

The number plates shall be affixed visibly at the front and on the rear sides of the motorcycle. They shall in no circumstances cover, throughout the duration of the Baja, even partly, the registration number of the motorcycle.

**55.07**

The figures must be clearly legible and like the background must be painted in matt colours to avoid reflection from sunlight. The minimum dimensions of the letters being:

- Height of the number 140 [mm]
- Width of figure 80 [mm]
- Width of the stroke 25 [mm]
- Space between two figures 15 [mm]

**55.08**

The English form for numbers must be used. That is single vertical line for the "one" and a simple sloping line without a horizontal line for the "seven". (See Diagram O).

**55.09**

All other number plates or markings on a motorcycle liable to cause confusion with the number must be removed before the start of a competition.

**55.12 Number plate colours**

The number plates for the FIM Bajas World Cup shall be as follows:

<b>Class</b>	<b>Background colour</b>	<b>Number colour</b>
450cc	White	Black
Quads	White	Black
Women	Purple	White

The colours must be matt, following the RAL colour table, example :

YELLOW	1003
RED	3020
PURPLE	4006
BLUE	5005
GREEN	6002
BLACK	9005
WHITE	9010

Regarding Support races/classes:

The colour of the number plates will be left at the discretion of the Organiser and will be specified in the SR's.

### **55.13**

In case of a dispute concerning the legibility of numbers, the decision of the Technical Steward will be final.

## **01.56 LIGHTING, WARNING EQUIPMENT AND SPEEDOMETERS**

Motorcycles and their equipment must comply with the national legal requirements for road traffic of the country in which the vehicle is registered and with other rules specified in the Supplementary Regulations.

The original headlights and rear lights may be modified or replaced. Extra lights may be added.

The electric generator must operate continuously and normally with respect to current and voltage requirements to run front and rear lights during the competition and at post competition control. The electrical connections must be retained.

## **01.58 ADDITIONAL SPECIFICATIONS FOR 450CC**

These vehicles are registered (allowed to be used on roads open to traffic) and can be modified and/or equipped for Bajas competition.

All motorcycles will be according to Art. 01.07.

### **58.01 Engine capacity**

450cc category:

Single cylinder engines up to 450cc 2T or 4T

### **58.02 Engine**

The engine number must remain visible at all times.

Engine preparation is free

During the event, an “engine change” means removing the engine from the frame. Engine “A”, originally fitted in the frame of the bike can be removed from the frame to be repaired and be replaced by engine “B”. Engine “A” may be repaired during the Event on condition that the engine crankcase marked during the preliminary technical inspection remains the same.

Repairs to the engine’s “top end” (cylinder + cylinder head) are free during the event. All intervention to the “bottom-end” (inside the crankcases) will be considered as a change of engine.

A minimum of one bolt/nut used to fix the engine must be drilled in order to attach a seal embracing the frame.

The engine may be removed from the frame to repair a problem not related to the crankcase. This may be done only under the supervision of the Technical Steward. The Technical Steward only can cut and replace the seals without being penalised.

### **58.03 Frame and ancillaries**

The main frame must be marked with the original Vehicle Identification Number (VIN). The frame number (VIN) must remain visible at all times.

The frame shall not be replaced during the event. The frame may be repaired under the supervision of the Technical Steward.

### **01.59 ADDITIONAL \* SPECIFICATIONS FOR QUADS**

\*The present Art. 01.59 prescribes additional rules for Quads, while the rest of the book applies.

These vehicles shall be registered (allowed to be used on roads open to traffic).

Top speed is limited to 130km/h

Quads are set in two Groups :

#### **01.59.1 Group G/ Quad Racers: propelled by the action of two wheels (2 wheel driven).**

Engine must be produced in a series and available on the market. Cylinder, cylinder head may be modified, with the exception of the crankcase, but must fulfil the FIM Technical Rules for Cross-Country Rallies Quads category.

The chassis must be produced in a series and available on the market, only competition related modifications are permitted. Chassis and engine must match. In case of a dispute, the decision of the Chief Technical Steward/ FIM Technical Director will be final.

### **01.59.2 Group H/ Quad Racers: propelled by the action of four wheels (4 wheel driven).**

Refer to Article 01.07 Classes for definition.

The engine minimum production quantities for engines shall be: 200 units\*

\*The minimum required production quantities refer to units with identical equipment.

Evidence of engine production quantities may be required by FIM, certified by the manufacturer's auditing firm and/or any other institution which may provide reliable documentation written in English.

### **59.01 Engine capacity**

Group G:

- from 250cc up to 350cc for two cylinder, 2-stroke engines
- up to 500cc for single cylinder, 2-stroke engines
- up to 750cc for single cylinder, 4-stroke engines.

Group H:

- up to **1000cc** ~~900cc~~ for single or twin cylinders, 4-stroke engines.

### **59.02 Engine**

The engine must be produced from a recognised and FIM licenced manufacturer.

The engine number (stamped on the crankcase) must remain visible at all times.

The following engine specifications and components may be altered from the original model:

- 1) Cylinder head:  
Intake and exhaust tracts surfaces may be polished. No addition of material is allowed.  
The gasket is free and compression ratio can be modified.
- 2) Camshafts and camshaft sprockets are free.  
Valve springs can be replaced but titanium springs are forbidden.
- 3) Pistons, pistons rings, pins and clips: may be altered or replaced from those fitted to the engine.
- 4) Exhaust system:  
Exhaust pipes and silencers may be altered or replaced.
- 5) Clutch: An aftermarket or modified clutch is permitted.
- 6) Radiator and/or oil cooler may be altered or replaced, additional radiators and oil cooler may be added.

- 7) Oil pumps and oil liners may be altered or replaced. Oil lines containing positive pressure, if replaced, must be of metal reinforced construction with swaged or treaded connectors.
- 8) Oil tanks may be added or modified.
- 9) Air filter may be altered or replaced.
- 10) Fuel pump may be modified or replaced.
- 11) Ignition / Engine Control System (ECU), hardware and software may be modified or changed.
- 12) Generator, alternator, electric starter may be modified or replaced.
- 13) Secondary transmission is free.

During the event, an 'engine change' means removing the engine from the frame. Engine 'A' originally fitted in the frame of the bike can be removed from the frame to be repaired and be replaced by engine 'B' Engine 'A' may be repaired during the event on the condition that the engine crankcase(s) marked during the preliminary technical inspection remain(s) the same.

Repairs to the engine's 'top end' (cylinder + cylinder head) are free during the event. All intervention to the 'bottom-end' (inside the crankcases) will be considered as a change of engine.

A minimum of one bolt/nut used to fix the engine must be drilled in order to attach a seal embracing the frame.

The engine may be removed from the frame to repair a problem not related to the crankcase. This intervention may be done only after formal request and under the supervision of the Technical Steward. Only the Technical Steward can cut and replace the seals without the participant being penalised.

### **59.03          Steering**

The machine can operate on the front wheels only.

### **59.04          Chassis and ancillaries**

Shock absorbers and associated springs are free.

Wheelbase, front and rear track are free but the overall width is defined by Art. 59.11.

The main chassis must be marked with the original Vehicle Identification Number (VIN). The frame number (VIN) must remain visible at all times.

The chassis shall not be replaced during the event. The frame may be repaired under the supervision of the Technical Steward.

For Group H only:

The main chassis may only be altered by addition of material, no material can be removed (except original engine fixing points if an alternative unit is installed).

The position on the chassis of steering pipe, swing arm, suspension linkage mounting points must remain as in the production Quad.

The rear sub-frame can be modified, but the type of material must remain as in the production model and the weight cannot be lower.

Fairing and body can be modified or replaced.

Seat may be modified or replaced.

Battery may be changed but the nominal energy must be equal or higher than the original one.

Footrests and foot controls may be modified or replaced.

#### **59.05 Number plates**

Four number plates are required:

- 1 plate fixed to the front of the machine at the level of the head lamp, facing forward.
- 1 double-side rear plate made of flexible material set on the safety bar placed behind the saddle of the quad.

#### **59.06 Suspensions**

All the mountings of the front and rear suspension units, suspension arms and the steering spindle are retained by a safety wire or a splitpen.

For Group H only:

Steering linkages and suspension arms may be modified or replaced. The FIM may require demonstrating that the new parts present equivalent or higher mechanical properties to the original ones.

#### **59.07 Brakes, wheels and rims**

Disc brakes, callipers and associated pipes can be changed.

The rear wheel rim diameter cannot exceed 12 [inches] in Group G and 15 [inches] in Group H. Wire spokes are not authorised.

Every front wheel must have a single, functional brake installed on each axle and be operated by a handlebar mounted lever.

At the rear, the vehicle must have a brake on each wheel or a brake installed jointly on the rear wheel axle, operated either by a lever on the handlebar or by a foot pedal.

Wheels may be replaced but not modified. Magnesium alloys and carbon-reinforced wheels are forbidden.

#### **59.08 Mudguards**

The front and rear wheels must be covered by mudguards made of flexible materials, covering each wheel over an area of minimum 30 degrees.

#### **59.09 Fuel tank(s)**

Supplementary fuel tanks are allowed but must be at least 25 [mm] (1 [inch]) away with relation to the edges of the protective barrier.

Original fuel tanks can be modified or replaced but the fixing points on the chassis and the fixing system must be as in the original model. Supplementary fuel tanks are allowed.

#### **59.10 Protection (Diagram Q)**

The secondary chain transmission must be equipped with a cover/shield protecting both the chain sprocket and the brake disc.

A compulsory countershaft sprocket guard must cover the sprocket by 30% minimum and prevent the rider's hand/foot becoming trapped.

The complete length of the lower chain run must be shielded by a guard or a protection tube, securely fixed.

A crash 'bar' or 'guard' must be fixed at the front and the rear of the vehicle.

A protective barrier (or 'guard') of a round profile (minimum diameter: 25 [mm] or 1 [inch]) must be installed on each side of the vehicle. This protective barrier must be fitted in such a way that it is in alignment with the wheels to eliminate entanglement. There shall be no prominent (sharp) parts.

A structure of crossed belts or a metallic grid must be fitted to fill the opening between the wheels and the barrier, to prevent the riders' foot from accidentally touching the ground.

#### **59.11 Dimensions**

The width cannot exceed 1300[mm] for group G and 1400 ~~1400~~ **1450**[mm] for group H.

The maximum height at the rider's seat level is 950[mm] for group G and 4000 ~~1100~~[mm] for group H (with all liquids at operational level and full fuel tank, and without the rider).

## **01.65 EQUIPMENT AND PROTECTIVE CLOTHING DURING PRACTICE AND RACE**

The FIM cannot be held liable for any injuries that a rider or passenger may sustain from the use of a specific item of equipment or protective clothing.

### **65.01 Clothing and protectors**

It is compulsory that riders wear either a suit or trousers and long-sleeve shirt.

Repaired overalls are acceptable provided that the repair guarantees protection to the same standard as the original garment. The Chief Technical Steward has the right to refuse any temporary repairs which are not deemed to provide the same protection as the original garment.

Any modifications brought to the protectors remove the certification of the equipment and will not be accepted.

If the clothing and/or protectors listed below does not meet the technical requirements or is found to be defective, the Technical Steward must clearly mark in red (e.g. with a red dot) all international marks without destroying them and retain it until the end of the event. The rider must submit another clothing and/or protectors for approval by the Technical Steward. After an accident involving impact, the back and chest protector must be presented to the Technical Steward for examination.

#### **65.01.1 Airbags**

It is compulsory that riders wear an airbag eligible for competition. By eligible for competition it is to be understood: an airbag system (complete vest or gilet) inside which the chest and back protector are included. The current version of airbag system eligible for competition is available here: [https://www.fim-moto.com/en/documents?tx\\_solr%5Bq%5D=airbag](https://www.fim-moto.com/en/documents?tx_solr%5Bq%5D=airbag)

#### **65.01.2 Limb joints protectors**

It is recommended that riders wear limb joint protectors for knees, hips, elbow and shoulders.

The limb joint protectors, if present, should be certified according the International norm:

- EN 1621-1, Level 1 or 2

#### **65.01.3 Back protector**



It is compulsory that riders wear a back protector.

The back protector must be certified according the International norm:

- EN 1621-2, Level 1 or 2, only CB (Central Back) or FB (Full Back)

#### **65.01.4 Chest protector**

It is compulsory that riders wear a chest protector.

The chest protector must be certified according the International norm:

- EN 1621-3, Level 1 or 2

#### **65.02 Footwear**

Footwear, in a good condition, made of leather or other materials having equivalent properties, shall be worn and have a minimum height of 30 [cm].

#### **65.03 Gloves**

Riders shall wear gloves made of leather or other materials having equivalent properties.

#### **65.04 Eye protection**

Riders shall wear goggles. The use of glasses, helmet visors and "roll offs" is also permitted. The use of "tear offs" is forbidden for environmental reasons. The material used for glasses, goggles and visors must be made of shatter-proof material. Helmet visors must not be an integral part of the helmet.

Eye protectors which cause visual disturbance (e.g. scratched) must not be used.

#### **01.67 WEARING OF HELMETS**

- It is compulsory for all participants taking part in practice and races to wear a protective helmet. The helmet must be properly fastened, be of a good fit, and be in good condition. The helmet must have a chin strap type 'retention system'.
- A protective lower face cover must be present and must be not detachable and not moveable.
- Helmets constructed with an outer shell made of more than one piece are not permitted (e.g. they must not contain any seam).
- A retention system with a strap and the double D ring closing system is recommended.

- All helmets must be marked with one of the official international standard marks mentioned in Art. 01.70. Any FMN approval marks do not substitute the official international standard marks.
- A helmet is made to provide protection. A helmet is not a platform to attach foreign objects. Cameras or other accessories are NOT permitted nor shall be attached to the rider's helmet.
- Long hair must not come out of the helmet. Long hair must be completely contained within the helmet.

Failure to observe the above rules will entail exclusion.

## **01.69 HELMET OPERATIVE INSTRUCTIONS**

### **69.01**

Scrutineers, under the supervision of the Chief Technical Steward, may check prior to practice and the races that all helmets meet the technical requirements.

### **69.02**

If a helmet does not meet the technical requirements or is found to be defective, the Technical Steward must clearly mark in red (e.g. with a red dot) all international marks without destroying them and retain the helmet until the end of the event. The rider must submit another helmet for approval by the Technical Steward. After an accident involving impact, the helmet must be presented to the Technical Steward for examination.

### **69.03**

All helmets must be intact and no alteration must have been made to their construction. After an accident involving a shock or impact, the helmet must be presented to the Technical Steward for examination.

### **69.04**

The Chief Technical Steward and/or the Technical Steward may perform the following checks before the rider is permitted to take part in practice of the race:

**69.04.1** That the helmet fits well on the rider's head.

**69.04.2** That it is not possible to slip the retention system over the chin, when fully fastened.

**69.04.3** That it is not possible to pull the helmet over the rider's head by pulling it from the back of the helmet.

### 01.70 RECOGNISED HELMET APPROVAL MARKS

Helmets must conform to one of the recognised international standards:

EUROPE	ECE 22-05 or ECE 22-06 (only "P" type)
JAPAN	JIS T 8133:2015 (only "Type 2 Full face")
USA	SNELL M 2015 or SNELL M 2020D or SNELL M 2020R

Examples of labels are reported below:

<p>EUROPE</p>	
<p>JAPAN</p>	
<p>USA</p>	

As from 01/01/2025, FIM homologated helmets according to the FRHPhe-02 (with a valid FIM homologated label) will be strongly recommended (if already available), and will be mandatory as from 01/01/2026. All the other standards will be forbidden.

A list of FIM Homologated helmets will be available on [www.frhp.org](http://www.frhp.org)

<b>FRHPhe-02 (FIM)</b>	<b>TBD</b>
------------------------	------------

### **01.75 BADGE OF THE FIM**

Under certain circumstances the FIM may permit the use of the FIM badge on certain equipment in order to show that the latter conforms to the standards laid down by the FIM. When this authorisation is granted and provided the equipment on which it appears is in good condition, the badge is then the guarantee of the conformity with the standard set by the FIM.

### **01.76 NUMBER SASHES (BIBS)**

The starting number on the rider's bib or vest must be the same as on his motorcycle.

Starting numbers must be in conformity with the following specifications:

#### **76.01**

Black numbers on a white background must be used.

#### **76.02**

The size of the area in which numbers are printed is: 25 x 25 [cm] maximum.

#### **76.03**

Height of number: 15 [cm].

#### **76.04**

Width of number: 6 [cm].

#### **76.05**

Width of stroke: 2 [cm].

#### **76.06**

Only the space outside the 25 x 25 [cm] area may be used for publicity.

#### **76.07**

Bibs manufactured from PLASTIC material are not allowed.

### **01.77 TECHNICAL VERIFICATIONS**

## 77.01 Preparation

- Prior to the Technical Verifications, it should be decided who is doing what and note decisions. "Efficiency" must be the watchword. Always keep cheerful and remember the reasons for scrutineering: SAFETY AND FAIRNESS.
- Before the START of the competition, a closed and guarded area (closed parc/parc-fermé) shall be prepared.
- Inspection must take place under cover with a large enough area.
- Inspection area must be supplied with the necessary equipment, including tables, chairs, electric light and power outlet.
- The necessary tools are listed below:
  - ✓ Revolution meter
  - ✓ Sound meter, calibrator and spare batteries
  - ✓ Slide calliper (for verifying engine capacity, carburettor diameter, etc.)
  - ✓ Depth gauge
  - ✓ Steel measuring tape
  - ✓ Arrangement for measuring ground clearance (for Sidecars)
  - ✓ Seals
  - ✓ Weighing apparatus (to be furnished by the Organiser) (and set of reference weights)
  - ✓ Tools for measuring the engine capacity
  - ✓ Lampoil tester is recommended and when used, it indicates the cylinder capacity. When a more precise measurement is required, the Chief Technical Steward may ask to take the cylinder head off the cylinder.
  - ✓ Colour for marking parts
  - ✓ Heat resistant stickers or paint for marking the silencer (and solvent)
  - ✓ Magnet
  - ✓ Adequate fuel sample bottles
  - ✓ PC with CD Drive + updated operating system
  - ✓ Printer, etc. are recommended
  - ✓ Calculator
- The necessary documents are listed below:
  - ✓ Supplementary Regulations
  - ✓ FIM Technical Rules - current year
  - ✓ FIM Rules of the discipline concerned
  - ✓ FIM Sporting Code
  - ✓ Homologation papers (if applicable)
  - ✓ Writing material
  - ✓ Technical Verifications forms

- All necessary measures and administrative equipment should be in place at least 1/2 hour before the start of the Technical Verifications is due to open (time in Supplementary Regulations).

## 77.02 Verifications

- The Technical Verifications must be carried out in conformity with the procedure and times fixed in the CEN Rules and the Supplementary Regulations of the event.
- The Sound control must be carried out first. The Sound level will be recorded in the technical card. The exhaust silencer will be marked with paint or sticker.
- An example of minimum verifications that shall be performed is given below:

<b>INITIAL TECHNICAL VERIFICATIONS</b>	TRIAL	MOTO CROSS	TRACK RACING	ENDURO	<b>CROSS-COUNTRY RALLIES and BAJAS</b>
Make + model	✓	✓	✓	✓	✓
Sound	✓	✓	✓	✓	✓
Cut-off switch	✓	✓	✓	✓	✓
Self-closing throttle	✓	✓	✓	✓	✓
Lights (front, rear, brake)	✓*			✓*	✓
Race fuel certificate	✓	✓	✓	✓	✓
Vehicle identification plate/chassis number				✓	✓
Crankcase				☐	☐
Wheels (hubs)				☐	☐
Registration plate + insurance (green card)				✓	✓
Weight + ballast	✓	✓	✓		
Fuel tank	✓				✓
Silencer	✓	✓	✓	✓	✓
Carburettor			✓		
Guard for the countershaft	✓	✓	✓	✓	✓

sprocket and rear sprocket					
Handlebar ends + protection + levers	✓	✓	✓	✓	✓
Front/rear brake disc protection	✓				
Side stand				✓**	✓
Tyres	✓	✓	✓	✓	✓
Helmet(s) + national colors	✓	✓	✓	✓	✓
Protective clothing	✓	✓	✓	✓	✓

\* not applicable for closed circuits when specified in the Supplementary Regulations

\*\* not applicable in SuperEnduro

- An overall inspection of the motorcycle must be carried out in conformity with the FIM rules. On accepted motorcycles a sticker or paint will be applied on the front of the main frame, in conformity with Arts. 082.8.2.1 of the Bajas Appendices.
- The Technical Verifications will only be carried out when the Technical Verifications form of the motorcycle has been presented by the rider or his mechanic.
- The fuel tank shall contain a minimum amount of fuel for the sound control.
- At the arrival, at the end of the competition, all the marked parts on the motorcycles must be controlled. After control, the machines must be placed in a closed park for 30 minutes after arrival of the last rider from the class concerned, in case a protest is lodged or further examination is required.
- If a motorcycle or a part of a motorcycle has to be verified and completely dismantled, the motorcycle, the part or the group of parts must be sealed and shipped to a place where the required tools are present for a disassembly. The Clerk of the Course/FIM Race Director must take the decision for this operation.
- The disassembly and the verification of the motorcycle or the parts in question must take place in the presence of the Technical Steward, appointed to the event.
- The Organiser will pay the costs for the transportation and for the verification according to Art. 77.02.14 and 77.02.15.
- If a disassembly is required and ordered by the Clerk of the Course/FIM Race Director, following a protest, according to Art. 77.02.14 and 77.02.15, the losing party will incur all the transportation and verification costs, or a part of these costs fixed by the Clerk of the Course/FIM Race Director.

### 77.03 FMNR Chief Technical Steward and technical stewards

- The Chief Technical Steward must be in attendance at an event one hour before the Technical Verifications are due to begin. He must inform the Clerk of the Course/FIM Race Director and FIM Technical Director, if present, of his arrival.
- The Chief Technical Steward must ensure that all technical stewards appointed for the event carry out their duties in a proper manner. The Chief Technical Steward shall appoint the technical stewards to individual posts for the race, practices and final control.
- Scrutineers can have different tasks, but the team of scrutineers must have a minimum of four persons. The FMNR Chief Technical Steward must be a holder of an FIM SENIOR Technical Stewards Licence and at least one Technical Steward must hold a FIM Technical Stewards Licence. A minimum number of scrutineers is required according to the following:
  - Sound test, silencer marking: two
  - Machine inspection, helmet and clothing: twoIt is recommended to have 2 up to 4 helpers (staff).
- The Sound Control Officer (SCO) must be holder of a valid FIM Technical Steward's license, come with good knowledge and experience of the sound control and application of the test method. The FMNR may propose the services from a special technician (acoustic engineer) if there is no FIM licenced Technical Steward available to act as SCO.
- After the Technical Verifications has been completed the Chief Technical Steward will submit to the Clerk of the Course/FIM Race Direction a list stating the names of the accepted riders, machines and the sound levels.
- During the event, in the arrival and departure areas, the technical steward must control the repairs and changes made to the machines. He must control that no outside assistance is made. He must also control the condition of the machines.
- At individual time checks, the technical steward must control repairs and other technical assistance. He must also control that the machines are marked in order to ensure that no change in motorcycle occurred on the course.
- At the arrival, at the end of each day, the technical steward must check all parts and the condition of the machine. A rider is allowed an extra 30 minutes to repair or replace a silencer and/or exhaust pipe only.
- If a motorcycle is involved in an accident, the Technical Steward must check the machine to ensure that no defect of a serious nature has occurred. However, it is the responsibility of the rider to present his machine for this re-examination together with the helmet and clothing worn.
- The Chief Technical Steward has the right to look/ inspect any part of the motorcycle at any time of the event.



- All technical stewards shall be well informed and shall make sure their FMN has supplied them with all technical "updates" that may have been issued subsequent to the printing of the Technical Rules books.

#### **77.04 FIM Technical Director**

- The FIM Technical Director is appointed by the Director of the FIM International Technical Commission in consultation with the Director of the FIM Cross-Country Rallies Commission.
- The FIM Technical Director is not responsible for the technical verifications but will ensure that they are carried out in accordance with the FIM Technical Rules.
- The FIM Technical Director works in cooperation with the FIM Race Director and the FIM Delegate.
- The authority and duties of the FIM Technical Director include but are not limited to (Please, also refer to the FIM Technical Rules):
  - a) The FIM Technical Director will report any concerns or deficiencies relating to the technical verifications to the FIM Race Director and FIM Delegate and present proposals to resolve such concerns.
  - b) The FIM Technical Director is the final arbiter in relation to technical issues at the event.
  - c) The FIM Technical Director will examine with the Chief Technical Steward the motorcycle(s) and the protective equipment of any rider(s) involved in serious or fatal accidents and present a written report to the FIM Delegate.
  - d) The FIM Technical Director will attend all meetings of the Race Direction, but without voting rights.

#### **77.05 Rider and/or mechanic**

- The rider and/or the mechanic and/or the Team Manager must attend at least once the Technical Verifications with the (rider's) machine within the time limits stated in the Supplementary Regulations.
- On request of the technical steward, the rider must present themselves to the Technical Verifications.
- The maximum number of persons present at the technical verifications will be the rider and/or the mechanic and/or the Team Manager.
- A rider remains at all times responsible that his machine and his personal protective gear are in conformity with the FIM Bajas Technical Rules.

- The rider and/or the mechanic and/or the Team Manager must present a clean motorcycle in conformity to the FIM Bajas Technical Rules and a duly filled in and confirmed Technical Verification form.
- A rider and/or the mechanic and/or the Team Manager must present one motorcycle only.
- The rider and/or the mechanic and/or the Team Manager must present the rider's protective wear (equipment), e.g. helmet and clothing.
- Riders/mechanics/Team Managers must confirm their agreement by signing the register. The motorcycles will then be placed in a closed park.
- Competitors must retrieve their machines within 30 minutes after the opening of the closed park area, except for the machines that are chosen for disassembly. After this time limit, the closed park officials will no longer be responsible for the machines left behind.
- Any rider failing to report as required by the provisions below may be excluded from the meeting.
- The Clerk of the Course/FIM Race Director may prohibit any person who does not comply with the rules, or any rider who could be a danger to other participants or to spectators, from taking part in the competitions.

#### **01.78 DANGEROUS MACHINES**

If, during practice or the race, a Technical Steward finds that a machine is defective and might constitute a danger to other riders, he must immediately notify the Clerk of the Course/FIM Race Director or his deputy. It is their duty to exclude such a machine either from the practice or from the race itself.

#### **01.79 SOUND CONTROL**

Exhaust pipes and silencers must fulfil all the requirements concerning sound control (see also FIM Sound Regulation).

# **Technical Rules SSV's**

# **Règlement Technique SSV**

## Table of contents

01.80	DEFINITION.....	36
01.81	REQUIREMENTS .....	36
01.82	FUEL TANK .....	36
01.83	CHASSIS .....	38
01.84	SAFETY CAGE .....	38
01.85	SEATS .....	39
01.86	SEAT HARNESSSES.....	39
01.87	BODYPANEL .....	42
01.88	INTERIOR.....	43
01.89	TRANSMISSION.....	43
01.90	MINIMUM WEIGHT.....	45
01.91	ENGINE .....	45
01.92	ELECTRICAL EQUIPMENT.....	48
01.93	SUSPENSION.....	49
01.94	WHEELS .....	50
01.95	BRAKING SYSTEM .....	52
01.96	STEERING.....	52
01.97	FIRE EXTINGUISHERS.....	53
01.98	LIGHTS .....	55
01.99	DRIVER AND CO-DRIVER EQUIPMENT.....	55

## 01.80 DEFINITION

SSV (Side-by-Side Vehicle) are motor vehicles propelled by a single thermal engine, four wheels, two- or four-wheel driven (designated 4X2 or 4X4), produced in series, (minimum 100 units), equipped with a steering system and a steering wheel, controlled by the rider. The seat of the driver and the passenger are positioned 'side-by- side'.

SSV's must be originally designed for 1-, 2- or 4- passengers and fitted with all the equipment required in the international convention on public road circulation. These vehicles must have a circulation insurance and a registration plate approved by the local Institute of Mobility and Transport (IMT) as a quadricycle, T1, T2, T3, or equivalent entity in the case of vehicles registered abroad.

Original part(s): A part which has undergone all the stages of production foreseen and carried out by the manufacturer of the vehicle concerned, and originally fitted on the production vehicle.

## 01.81 REQUIREMENTS

### 81.01 Fuel tanks

Any tank containing oil or fuel must be situated in the main structure of the vehicle (position of the fuel tank: see article 82.05).

If the OEM fuel tank is kept, no changes are necessary. If an additional tank is mounted that tank must comply with these regulations.

### 81.02 Materials

Unless explicitly authorised by the present regulations, the use of the following materials is prohibited unless it corresponds exactly to the material used in the same components of the production vehicle:

- Titanium alloy
- Magnesium alloy
- Ceramics
- Composite

### 81.03 Registration plate

The original registration plate must be securely fitted to the rear of the vehicle. It must always be visible and with its own lighting. The sharp edges must be covered to prevent injuries.

### 81.04 Screws, nuts and bolts

Unless otherwise stated, all threaded fasteners must be manufactured from iron-based alloys or aluminium-based alloys.

### 81.05 Maximum speed

130 km/h

## 01.82 FUEL TANK

The fuel tank must be the original of the vehicle or homologated according to an International Standard for Motorsport Safety.

### 82.01 Number of fuel tanks

Maximum number of fuel tanks: 2

### 82.02 Fuel tanks capacity

Maximum combined capacity of the fuel tanks is 130 litres

### **82.03 Fuel tanks shielding**

All vehicles must have shielding (6 [mm]. minimum thickness for aluminium alloy plate or 3 [mm]. minimum thickness for steel plate) fitted directly onto the chassis underneath any part of the tank(s) situated less than 200 [mm] above the plane defined by the lower face of the lowest tubes of the chassis that are situated within the vertical projection of the fuel tank(s).

### **82.04 Fuel tanks housing**

The soft tanks must be contained in a leak-proof housing securely attached to the chassis/safety cage, the minimum specifications of which are as follows:

- Sandwich construction "Glass Reinforced Plastic + Kevlar or Carbon + Kevlar with an intermediate layer of absorbent material" with a minimum wall thickness of 10 [mm]
- Aluminium alloy with a minimum wall thickness of 3 [mm] except for the areas for mounting to the chassis.

A leak-proof cover, made from non-flammable material, easily accessible and removable only with the use of tools, must be installed in the protection for tanks, in order to allow the checking of the validity expiry date.

No part of this housing may be situated less than 40 [mm] above the lower face of the lowest tubes of the chassis that are situated within the vertical projection of the fuel tank.

The housing must not be:

- Longitudinally less than 800 [mm] rearward of the front axle centreline,
- Transversally less than 50 [mm] (inwards) from the outer part of the main rollbar feet
- Vertically less than 200 [mm] from any point of the upper part of the main rollbar.

### **82.05 Fuel tanks position**

Parts ahead of the back of the seats must be situated below the mounting points of the seats to the chassis.

Any fuel tank must be situated inside the main structure of the vehicle.

If the OEM fuel tank is maintained, its original location must be kept.

### **82.06 Fuel tanks filler hole**

The fuel tank filler hole must be situated outside the cockpit.

### **82.07 Fuel tanks outlet**

The outlet of the fuel tank breather and hose must be kept away from hot areas. A safety valve must be installed (and remain visible during all the technical scrutineering procedure(s); it must close automatically by gravity in case of a rollover.

The breather hose should be raised to near the upper limit of the chassis and again directed downwards.

### **82.08 Fuel lines**

Fuel hoses must be resistant to fuel and must have a minimum burst pressure of 10 bars at the minimum operating temperature of 80°C.

All fuel lines which feed (or return from) the engine are recommended to be equipped with automatic fuel shut-off valves, positioned directly next to the fuel tank and shall automatically close all pipelines under pressure in the event of a rupture or loss.

### **82.09 Fuel cooling**

The fitting of fuel coolers is authorised on the return circuit to the tank.

## **01.83 CHASSIS**

### **83.01 Chassis**

Only tubular chassis in iron-based alloys are authorised.

### **83.02 Standard components**

The position of the following components must remain unchanged (unless otherwise specified) in relation to the standard vehicle:

- Mounting points of the suspension and shock absorber components
- Engine and its supports
- Transmission parts (gearbox / differentials ...)
- Steering rack
- Pedal box (see article 5.14)

All these components must be interchangeable (without modification) with those of the standard vehicle.

## **01.84 SAFETY CAGE**

The fitting of a safety cage is compulsory. The safety cage must be homologated according to an International Standard for Motorsport Safety with an homologation paper and/or identification plate. The safety cage must comply with FIM OFF-ROAD ADDITIONAL TECHNICAL REGULATION.

### **84.01 Around safety cage**

Inside the cockpit, the passage of the following elements between the side members of the body panel and the safety cage are forbidden:

- Electric cables
- Lines carrying fluids (except for drinking water and windscreen washer fluid)
- Lines of the fire extinguishing system.

Members may enter into the occupant's space by passing over the dashboard and trimming.

### **84.02 Safety cage protect padding (move A1.10)**

All tubes of the cage identified on Figure 3 and all roof reinforcements must be fitted with paddings approved for competition. Each padding must be fixed in such a way that it is not moveable from the tube and must be located everywhere the helmet can touch the cage.

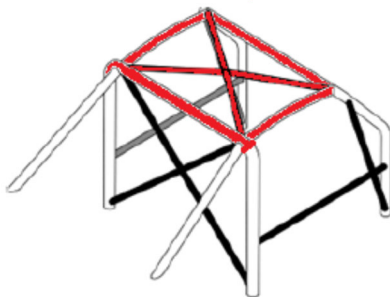

Figure 3

## 84.06 Driver/Co-driver back protection

The occupants' seats must be shielded by a protective panel, positioned directly behind the driver and passenger's seats. The protective panel must be rigidly fixed by welding or by bolts to the main roll-bar of the safety cage. This protective panel must withstand fire, made from steel or an aluminium alloy (minimum thickness 2 [mm]). This portion must cover the whole height and the whole width of the safety cage. Holes are permitted only to put safety equipment's (harnesses).

## 01.85 SEATS

All the occupants' seats must be homologated according to an International Standard for Motorsport Safety.

### 85.01 Seat attachments

Each seat must be attached to the chassis via at least 4 supports, 2 at the front and 2 at the rear of the seat.

Supports must be attached to the seat and the chassis using bolts with a minimum diameter of 8 [mm] (quality 8.8 or higher) and counter plates. The seats must have reinforcement at the locations of the fixation.

The minimum thickness of the supports and counter plates is 3 [mm] for steel and 5 [mm] for light alloy materials. The minimum longitudinal dimension of each support is 6 [cm].

The minimum area of contact between support, shell/chassis and counter plate is 40 [cm<sup>2</sup>] for each mounting point.

Each mounting point must be capable of withstanding a force of 15000 [N] applied in any direction. If quick release systems are used, they must be capable of withstanding vertical and horizontal forces of 18'000 [N], applied non-simultaneously.

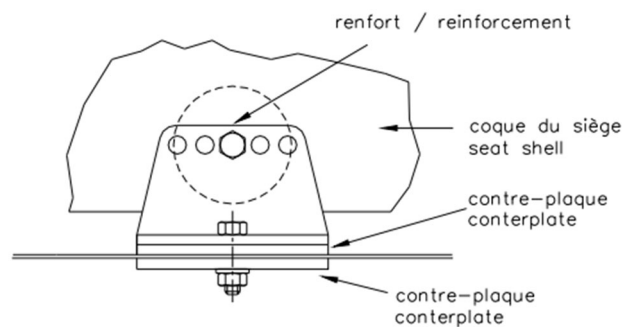

253-65

## 01.86 SEAT HARNESSSES

It is compulsory to use seat harnesses homologated according to an International Standard for Motorsport Safety for each occupant.

It is not allowed to mix parts of harnesses. Only complete sets, of proprietary manufacture, may be used.



The harnesses must be replaced after every severe collision, and whenever the webbing is cut, frayed or weakened due to the actions of chemicals or sunlight.

Elastic devices attached to the shoulder straps are forbidden.

Any harness which does not function perfectly must be replaced.

A safety harness must be used in its homologation configuration without any modifications or removal of parts, and in conformity with the manufacturer's instructions.

### 86.01 Seat harnesses anchored points

It is prohibited for the safety harnesses to be anchored to the seats or their supports. The anchorage points of the series vehicle can be used.

If the installation on the series anchorage points is impossible, new anchorage points must be installed on the chassis, a separate one for each strap the furthest rearward as possible for the shoulder straps.

Care must be taken that the straps cannot be damaged through chafing against sharp edges.

The recommended geometrical locations of the anchorage points are shown in Drawing below.

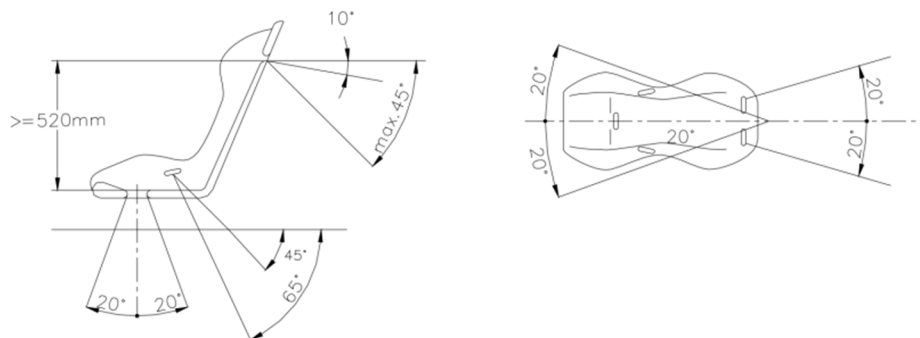

**Figure 4**

In the downwards direction, the shoulder straps must be directed towards the rear, and must be installed in such a way that they do not make an angle of more than 45° to the horizontal from the upper rim of the backrest, although it is recommended that this angle does not exceed 10°.

The maximum angles in relation to the centreline of the seat are 20° divergent or convergent (measurement in horizontal projection).

Anchorage points creating a higher angle to the horizontal must not be used.

If mounting on the series anchorages is impossible, the shoulder straps may be fixed or leaning on a rear transverse tube fixed to the cage or to the top anchorage points of the front belts.

The shoulder straps may also be fixed to the safety cage or to a reinforcement bar by means of a loop, and may also be fixed to the top anchorage points of the rear belts, or be fixed or leaning on a transverse reinforcement welded between the backstays of the cage (see Figure 5) or on transverse tubular reinforcements.

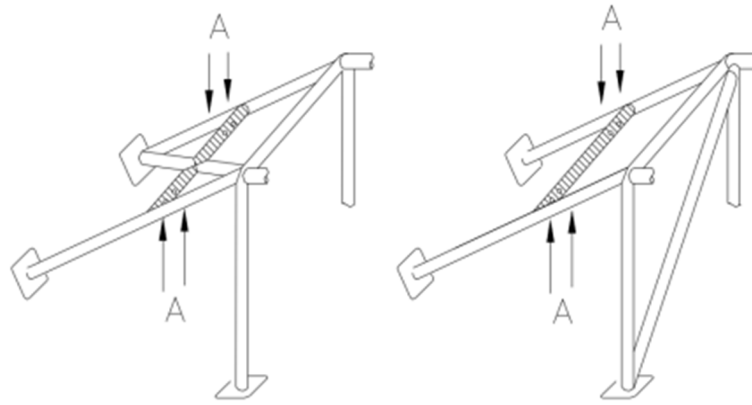

**Figure 5 : Mounting holes for harnesses**

In this case, the use of a transverse reinforcement is subject to the following conditions:

- The transverse reinforcement must be a tube measuring at least 38 [mm] x 2.5 [mm] or 40 [mm] x 2 [mm], made from cold drawn seamless carbon steel, with a minimum tensile strength of 350 [N/mm<sup>2</sup>]
- The height of this reinforcement must be such that the shoulder straps, towards the rear, are directed downwards with an angle of between 10° and 45° to the horizontal from the rim of the backrest, an angle of 10° being recommended.
- The lap and crotch straps must not pass over the sides of the seat but through the seat, in order to wrap and hold the pelvic region over the greatest possible surface.
- The lap straps must fit tightly in the bend between the pelvic crest and the upper thigh. Under no conditions must they be worn over the region of the abdomen
- The straps may be attached by looping or by screws, but in the latter case an insert must be welded for each mounting point.

These inserts must be positioned in the reinforcement tube and the straps must be attached to them using bolts of M12 8.8 (ISO standard, minimum) or 7/16 UNF specification.

Each anchorage point must be able to withstand a load of 1470 [daN], or 720 [daN] for the crotch straps.

In the case of one anchorage point for two straps (prohibited for shoulder straps), the load considered must be equal to the sum of the required loads.

For each new anchorage point created, a steel reinforcement plate with a surface area of at least 40 [cm<sup>2</sup>] and a thickness of at least 3 [mm] must be used.

The effectiveness and longevity of safety harnesses are directly related to the manner in which they are installed, used and maintained.

They must also be replaced if metal parts or buckles are bent, deformed or rusted.

### **86.02 Seat harnesses release**

Two belt cutters must always be carried on board (identified with a sign). They must be easily accessible for the driver and co-driver when seated with their harnesses fastened.

Furthermore, it is recommended that for competitions which include public road sections, the harnesses be equipped with push-button release systems.

## **01.87 BODYPANEL**

The vehicle must be fitted with its original body panel. The only modification allowed are the one requested by this regulation, when safety items are added for example.

A protective shield, installed on the top of the safety cage is compulsory, minimum thickness shall be of minimum 2 [mm] if it is made of steel or aluminium alloy.

A protective panel must be installed in front of the occupants' feet, on both sides of the SSV. This protection panel must be made of steel or aluminium with a minimum thickness of 2 [mm]. This panel must be attached to the chassis' tubes of the chassis

All parts of the body panel must be carefully and fully finished, with no temporary or makeshift parts and no sharp edges.

No mechanical component may be visible from above with the exception of shock absorbers, suspension arms, transversal driveshaft's, radiators, fans, wheels and spare wheels, including their anchorage points and attachments.

All parts having an aerodynamic influence and all parts of the body panel must be secured rigid to the completely sprung part of the vehicle (chassis/body unit); they must not have any degree of freedom, must be securely fixed and must remain immobile in relation to this part when the vehicle is in motion, with exception of the driver's and/or co-driver's ventilation sliders / scoops.

### **87.01 Exterior**

The maximum overall length is 3550 [mm] without spare wheels.

The maximum width the vehicle with of the body panel is 1900 [mm] without rear view mirrors and/or spare wheels.

A windscreen is optional. If a windscreen is installed, it must be made of non-breakable, shatterproof materials.

### **87.02 Lateral windows**

Free, but it must be possible to remove the front doors or the windows of the front doors from inside the cockpit without the use of tools.

### **87.03 Windscreen wipers, motor and mechanism**

These items are free.

### **87.04 Rear view mirrors**

The vehicle must be fitted with two rear view mirrors, one on each side of the car, to provide efficient views to the rear. Each mirror must have a minimum area of 90 [cm<sup>2</sup>].

### **87.05 Rear camera**

One rear view camera is permitted provided if it is non-swivelling.

### **87.06 Aerodynamic device**

Identical to the standard vehicle /no modification authorised.

### **87.07 Underbody protections**

The fitting of underbody protections is authorised on the following conditions:

- They must respect the ground clearance

- They must be removable
- They must protect only the following parts: engine, radiator, intercooler, gearbox, centre differential, rear differential, driveshaft's (longitudinal and transversal), subchassis, suspension parts, steering and exhaust line.

## **01.88 INTERIOR**

### **88.01 Interior safety**

The cockpit must be designed to ensure the comfort and safety of driver and possible co-drivers. No part may present sharp edges or points.

No mechanical part may protrude into the interior of the cockpit. Any equipment that could involve a risk must be protected or insulated and must not be situated in the cockpit.

The cars must have lateral openings allowing the exit of the driver / co-driver.

### **88.02 Inspection hatches**

Inspection hatches are authorised in the bulkheads of the cockpit.

### **88.03 Bulkhead**

A leakproof and flameproof bulkhead made of steel or aluminium alloy (minimum thickness 2 [mm]) or in composite material (minimum thickness 5 [mm]) is compulsory behind the seats and must be fully in contact with the main rollbar of the safety cage.

### **88.04 Protection nets**

Vehicles without side windows must be fitted with lateral protection nets attached to the main rollbar and doors using a quick release system or an articulated window rim. The use of "clip" fixings is recommended. The fixings of the net must not be removable without the use of tools.

These nets must have the following characteristics:

- Minimum width of the strips: 19 [mm]
- Minimum size of the meshes: 25 x 25 [mm]
- Maximum size of the meshes: 60 x 60 [mm]

The lateral opening circumscribed by the tubes of the lateral roll bar and the door upper side must be completely closed by the protection nets.

## **01.89 TRANSMISSION**

The complete transmission (except otherwise specified) of the standard vehicle must be kept without modification.

A modification is only allowed, in order to de-activate the active systems if necessary.

All the parts must be available, as spare parts, through the Manufacturer's commercial network.

### **89.01 Transmission shaft**

Transmission shafts are free but must be made of steel. In addition, they must be solid and in one piece and the joints must come from a series vehicle.

The transmission shaft location must be identical to the standard vehicle and must respect the following conditions:

- It may be situated inside or outside the cockpit.
- The floor of the cockpit must be closed with a metallic sheet, minimum thickness 1.5 [mm].
- The metallic sheet must be securely fixed to the chassis.

### **89.02 The transmission tunnel**

The installation of a transmission tunnel is mandatory if the transmission shaft is located inside the cockpit and can be modified with the following conditions:

- It must enclose the longitudinal shaft over the complete length of the cockpit.
- It must be made from a steel sheet of minimum thickness 1.5 [mm], or from a steel tube of minimum thickness 3.0 [mm].
- The transmission tunnel must be securely fixed to the floor or the chassis in such a way as to ensure that it cannot be detached during normal use or in case of an accident.
- The entire surface of the transmission tunnel must be free of any kind of hole, with the exception of the part attaching it to the floor or chassis.

If fitted outside the cockpit, a minimum of two steel safety straps, of minimum thickness 3.0 [mm] and minimum length 250 [mm], must be fitted to each longitudinal shaft to prevent it from hitting the ground in case of breakage.

Should any fuel or oil tank be close to a longitudinal shaft, it is compulsory that the tank has extra protection in the walls close to the shaft.

### **89.03 Pedal box**

Identical to the standard vehicle but the axis of the pedal box must be situated behind or directly above the axis of the front wheels.

### **89.04 Gearbox**

Modification authorised on the gearbox / differential housing is allowed only to install an additional lubrication system.

#### **89.04.01 CVT sytem**

Identical to the standard vehicle / no modification authorised.

The belt is free provided that it is available as a spare part (reinforced or not) through the Manufacturer's commercial network.

A system for cooling the belt by air is authorised.

#### **89.04.02 Manual or semi automatic or automatic operation control**

Identical to the standard vehicle / no modification authorised.

#### **89.04.03 Gearshift control**

Gear shift type is free.

The gear shift lever must be fixed on the floor or on the steering column and can be adjustable. If fixed on the steering column the link between the gear lever and the gearbox must not be by cable or electric wires in case of semi-automatic or automatic control.

#### **89.04.04 Cut-off sensor for gear command**

Identical to the standard vehicle / no modification authorised.

**89.04.05 Lubrication**

An additional lubrication and oil cooling device is allowed (circulation pump, radiator and air intakes)

**89.04.06 Clutch**

Free, but principle and diameter must remain identical to the standard vehicle / no modification authorised.

**89.04.07 Control system**

Hydraulic or mechanic or other. Identical to the standard vehicle / no modification authorised.

The clutch stop (clutch release bearing) is free.

**89.04.08 Master-cylinder and tank**

Master cylinder and hydraulic oil reservoir are free.

**89.04.09 Supports for Gearbox / CVT / Differentials**

Supports are free.

**01.90 MINIMUM WEIGHT**

No Minimum weight

**01.91 ENGINE**

The maximum cylinder capacity is set at 1050 [cm<sup>3</sup>] for normally aspirated engines and for supercharged engines. The engine of the standard vehicle must be kept as original without modifications.

**91.01 Positions and inclination of the engine**

Identical to the standard vehicle / no modification authorised.

**91.02 Engine supports**

Supports are free.

**91.03 Plastic shields**

Engine shields made of plastic material, the purpose of which is to hide mechanical components in the engine compartment, may be removed if they have a solely aesthetic function.

**91.04 Screws, nuts and bolts**

A nickel-based alloy may be used for the fixing of the exhaust manifold to the cylinder head.

**91.05 Gaskets**

All gaskets are free.

**91.06 Cylinder head gasket**

Identical to the standard vehicle / no modification authorised.

**91.07 Ignition**

The make and type of the spark plugs and leads are free.  
The use of ceramics for spark plugs is authorised.

**91.08 Fuel injection system**

**91.08.01 Fuel rail**

Free.

**91.08.02 Injectors**

Identical to the standard vehicle / no modification authorised.

**91.08.03 Electronic control unit (ECU) and engine control software**

The ECU is free but the electronic control unit must come from a large scale production catalogue or from a competition parts catalogue.

**91.08.04 Sensors**

Sensors shall be identical to the standard vehicle / no modification authorised.

**91.08.05 Actuators**

Identical to the standard vehicle / no modification authorised.

**91.09 Air intake system****91.09.01 Air filter**

The choice of air filter element and its position is free. The plenum chamber and the lines between the restrictor / manifold and the atmosphere are free. Engine intake air must not be taken from inside the cockpit and any modifications must not affect the structure of the vehicle.

**91.10 Supercharging system**

Identical to the standard vehicle (as homologated for public road).

**91.11 Pressure regulation valve (waste gate) / System for injecting air into the exhaust manifold**

These parts must remain identical as fitted on to the standard vehicle / no modifications authorised.

**91.12 Exhaust line**

The silencer(s) exit(s) must be horizontal and situated within the perimeter of the vehicle defined by the chassis, body panels, roll cage and mud flap brackets.

The exits of the exhaust system must be visible from outside.

The extremity of the silencer(s) must not pass the vertical tangent of the rear tyres.

The edges of the silencer(s) shall be rounded (straight, sharp cuts are not permitted).

All the exhaust gases (with the exception of the gasses coming from the wastegate) must pass through the silencer(s). Exhaust fumes must be discharged towards the rear but not in such a manner as to raise dust, foul the tyres or brakes.

Only the original (standard) installed exhaust valve systems provided by the manufacturer is authorised.

**91.13 Heat shielding of the exhaust system**

Heat shielding elements on the exhaust system or on components in close proximity to the exhaust system are authorised, but must be removable.

## **91.14 Cooling system**

The original water pump must be retained.

## **91.15 Coolant radiator**

The position of the coolant radiator is free but forbidden in the cockpit. The fans and their position are free, as are their electric looms.

Hot air shall be directed away from the driver/passenger's compartment.

## **91.16 Coolant lines**

The expansion chambers are free, provided that the capacity of the new chambers does not exceed 2 litres and that they are not located in the cockpit.

The liquid cooling lines external to the engine block and their accessories are free.

## **91.17 Lubrication system**

Radiator, oil/water exchanger, lines, thermostat, filter and pump strainers are free.

Oil pressure may be increased by changing the discharge valve spring.

If the lubrication system includes an open type sump breather, it must be equipped in such a way that the oil flows into a catch tank (minimum capacity: 1 [litre]).

The fitting of one or several ventilators for cooling the engine oil is authorised, provided that this does not have any aerodynamic effect.

## **91.18 Oil sump**

Identical to the standard vehicle / no modification authorised.

## **91.19 Exchanger (intercooler) of the supercharging system**

### **91.19.01 Intercooler**

Identical to the standard vehicle / no modification authorised.

### **91.19.02 Supports and position of the heat exchanger**

Support brackets and their position are free but are forbidden to be placed inside the cockpit.

### **91.19.03 Fans for cooling the exchanger**

Identical to the standard vehicle / no modification authorised.

### **91.19.04 Cooling air ducts of the exchanger**

Cooling air ducts are free.

### **91.19.05 Piping**

All pipes between the supercharging device, the intercooler and the manifold are free (on condition that they remain within the engine bay), but their only function must be to channel air and to join various parts together.

### **91.19.06 Accessories**

Except for the components mentioned in Art. 91.17 Lubrication System, the following accessories must derive from a homologated vehicle engine or from a commercial catalogue and be available for sale to the public:

- alternator
- air conditioning compressor
- air compressors



- fuel pumps
- hydraulic pumps

The number and position of these accessories are free provided that they remain within the engine compartment and/or within the main structure of the vehicle. They may not be placed within the cockpit area. Their method of operation drive systems is free.

Local machining and/or welding of an accessory is permitted for its fitting and/or function.

## **01.92 ELECTRICAL EQUIPMENT**

### **92.01 Wiring loom & Fuses**

All wiring loom (using appropriate size and diameter) and fuses are free.

### **92.02 Circuit breakers**

Circuit breakers may be freely changed regarding their use, position, or number in the case of additional accessories. The general circuit breaker must be a spark-proof model and must cut all electrical circuits, battery, alternator or dynamo, lights, horns, ignition, electrical controls, etc. and must also stop the engine.

At least two circuit breakers must be installed:

- One inside the cockpit: It must be accessible from inside the vehicle by the driver and the co-driver seated and secured by their safety harnesses
- One outside the cockpit.

### **92.03 Battery**

#### **92.03.01 Number**

Identical to the standard vehicle / no modification authorised.

#### **92.03.01 Type**

The make, capacity and cables of the battery are free. The nominal voltage must be the same or lower than that of the standard vehicle. The minimum weight of the battery is 3 [kg].

#### **92.03.01 Location**

The location of the battery(ies) is free, but the battery must be of the dry type if it is in the cockpit.

#### **92.03.01 Fixation**

Each battery must be securely fixed and the positive terminal must be protected.

Should the battery be moved from its original position, it must be attached to the body using a metal seat and two metal clamps with an insulating covering, fixed by bolts and nuts.

For attaching these clamps, metallic bolts with a diameter of at least 10 [mm] must be used, and under each bolt, a counter plate at least 3 [mm] thick and with a surface of at least 20 [cm<sup>2</sup>] beneath the metal of the body panel.

Wet batteries can be used, but must be placed and covered in a leakproof box, attached independently of the battery. The box must be attached independently to the chassis. The securing system must be able to withstand a deceleration of 25 [g].

## **92.04 Starter**

### **92.04.01 Location**

Identical to the standard vehicle / no modification authorised.

### **92.04.02 Make and type**

Identical to the standard vehicle / no modification authorised.

## **92.05 Data acquisition system**

A competitor data recording system is authorised, but only the following sensors are allowed:

- sensors fitted on the reference vehicle
- 3 temperature sensors (engine oil, engine water, gearbox or CVT)
- pressure sensors (1 oil and 1 fuel)
- 1 engine knocking sensor (only if fitted on standard engine)
- 1 fuel level gauge for each fuel tank
- any sensors necessary for the navigation system allowed by the supplementary regulations of the competition
- wheel speed sensors (maximum 2), only on driven wheels.

## **92.06 Sensors**

Any radar system, vehicle speed measurement system (except pulse ring on the gearbox), gyroscope, load sensor (except sensor for engine ignition and/or injection cut-off) or restraining gauge is forbidden.

Accelerometers are authorised for data logging only on condition they are built into the dash display equipment.

## **92.07 Transmission of data**

The transmission of data by WI-FI, radio and/or telemetry is prohibited.

## **01.93 SUSPENSION**

### **93.01 Suspension type**

It is forbidden to use active suspension (any system which allows control of flexibility, damping, height and/or attitude of the suspension when the vehicle is in motion).

### **93.02 Wishbones/suspension arms**

Suspension triangle arms are free, but must remain interchangeable with those of the standard vehicle and must be manufactured in steel. No modifications to their respective mounting points on the chassis are permitted.

### **93.03 Joints (wishbones/links and suspension parts)**

Rubber, ball joint, plain bearing, bearings (ball, roller, needle) : free

### **93.04 Hubcarriers/wheel bearings/wheel hubs**

Identical to the standard vehicle / no modification authorised.

### **93.05 Connection the hubcarrier and the wishbone**

Identical to the standard vehicle / no modification authorised.

### **93.06 Springs and shock absorbers**

Only one shock absorber per wheel is authorised. Shock absorbers are free but their mounting points to the chassis must remain identical as on the reference vehicle.

Any adjustment of the springs and/or shock absorbers from the cockpit is forbidden. Adjustment is only possible when the vehicle is not in motion and only with the use of hand tools. The adjustment device must be situated on the shock absorber or its gas reserve.

Any connections between dampers are forbidden, the only connections permitted are the shock absorber fixing points passing through the chassis; these must have no other function.

### **93.07 Springs**

A coil spring may be replaced with two or more springs of the same type, concentric or in series, provided that they can be fitted without any modifications other than those specified in this article.

### **93.08 Antiroll bars / fixings**

Free, but only one antiroll bar per axle is permitted.

The adjustment of the antiroll bars from the cockpit is forbidden.

The antiroll bar systems must be exclusively mechanical, with no activation or deactivation possible.

Any connections between front and rear antiroll bars are forbidden.

## **01.94 WHEELS**

The fitting of air extractors on the wheels is prohibited.

### **94.01 Rims**

The diameter of the wheel rim is set at a maximum of 15["]].

The rims and bead lock devices must be made of steel or aluminium alloy.

Wheel trims are forbidden

### **94.02 Tyres**

The tires must be off-road type with a maximum diameter of 770 [mm] (complete wheel) measured at 1,2 [bar] and dismounted from the vehicle.

The use of tyres intended for motorcycles is forbidden.

The fitting of intermediate parts between the rims and the tyres is forbidden. The use of tyre balls or tyre blocks is forbidden.

Only one air valve is allowed per wheel and it must be fixed to the rim by a single hole, which has a maximum diameter of 12 [mm] and is positioned on the outer face of the rim.

Modifying the tyre is not authorised. It is forbidden to treat tyres with chemicals, cut or groove them, use tyre warmers or any other means which may alter the shape, minimum Shore hardness, construction or other characteristics.

Only tyres normally available from commercial or retail sources are authorised. The tyres shall appear on the tyre manufacturers range catalogue and tyre specification lists available to the general public.

The E approval mark and number as defined by the UN Vehicle Regulation R75 must be present on both the front and rear tyres sidewalls. The DOT approval mark is also accepted.

The maximum gap between two adjacent tread blocks in any plane perpendicular or parallel to the tread is 15 [mm].

The maximum height for the tread blocks is 15 [mm].

These measures do not apply to a width of 30 [mm] from the sidewalls and on each side. Tread blocks shall not protrude directly from the sidewalls of the tyre.

### **94.03 Fixation**

A bolted "Beadlock" device is allowed.

Central nut wheel fixing is forbidden.

Wheel fixations by bolts may be freely changed to fixations by pins and nuts.

The wheels do not have to be of the same diameter.

Hub and nut protections are permitted.

### **94.04 System for inflating / deflating the tyres**

The use of any system for inflating / deflating the tyres when the vehicle is in motion is forbidden. The inflating / deflating operation must only be carried out while the vehicle is not in motion.

The only system authorised is a system connected to the wheels through a flexible tube during the operation and connected to one valve per wheel.

In order to adjust the tyre pressure, any air going in or out must pass through a conventional complete and unmodified VG5 type valve coming from a series light utility vehicle.

The tube and its inflating manometer may be situated in the cockpit on condition that the operating pressure is lower than 10 bars.

The system may be fed by a 12V electric compressor and/or by compressed air bottles.

#### **94.04.01 Compressed bottles**

If the system to inflate the tyres is composed by compressed air bottles it must follow these restrictions:

- Maximum capacity [3 litres] each
- The mountings must be able to withstand a deceleration of 25 [g]
- Must not be situated in the cockpit.
- Must be positioned transversally in the vehicle
- Secured by at least two metal strap each

### **94.05 Spare wheel**

The vehicle must be fitted with minimum one, maximum 2 spare wheel, free positions.

## **01.95 BRAKING SYSTEM**

### **95.01 Control system**

The pedal must normally control all the wheels and it is activated and controlled only by the driver. It includes at least two independent circuits operated by the same pedal (between the brake pedal and the callipers, the two circuits must be separately identifiable, without any interconnection other than the mechanical braking force balancing device).

The pressure is identical on the wheels of the same axle, with the exception of the pressure generated by the handbrake.

### **95.02 Brake disks**

All the wheels must have a brake disk. The discs must come from a series vehicle or from a catalogue of competition parts. Their maximum diameter is set at 290 [mm].

### **95.03 Callipers**

The callipers must come from a series vehicle or from a catalogue of competition parts with a maximum of 4 pistons.

Mounting spacers for brake callipers is free

### **95.04 Master-cylinders and tanks**

Free

### **95.05 Proportional valve**

Free

### **95.06 Pedal box**

Original / No modification allowed

### **95.07 Handbrake**

Free.

If the original vehicle is fitted with a handbrake, the function must be kept.

## **01.96 STEERING**

### **96.01 General**

The link between the driver and the wheels must be mechanical and continuous.

4-wheel steering is prohibited.

### **96.02 Steering wheel**

The steering wheel may be removable from the steering column through a quick release mechanism. This mechanism must consist of a flange concentric to the steering wheel axis, coloured yellow and installed on the steering column behind the steering wheel.

The release must be operated by pulling the flange along the steering wheel axis. Push buttons and switches may be fitted.

Padding in the form of 60-240 [g/m<sup>2</sup>] material, with a minimum thickness of 40 [mm], must be fitted on the steering wheel over a minimum surface of 20 000 [mm<sup>2</sup>] (200 [cm<sup>2</sup>]) to protect the driver's face.

**96.03 Steering mechanism**

Identical to the standard vehicle / no modification authorised.

**96.04 Steering mechanism position**

Identical to the standard vehicle / no modification authorised.

**96.05 Steering rods / Steering joints**

Free but must be interchangeable (without modification) with those of the standard vehicle.

**96.06 Steering column**

Free but if the reference vehicle is must be fitted with an unmodified OEM (Original Equipment Manufacturer) energy absorbing device, it must be kept (without modification).

The locking system of the anti-theft steering lock must be rendered inoperative.

**96.07 Support / steering column**

Free.

**96.08 Power steering**

Identical to the standard vehicle / no modification authorised.

**96.08.01 Oil cooling**

Oil radiators, as well as a system for circulating the oil without generating pressure, are authorised.

**96.08.02 Oil tank**

Free.

**01.97 FIRE EXTINGUISHERS****97.01 General**

All vehicles must be fitted with one or two manual fire extinguishers. It must be possible to activate the fire extinguishers by the occupants or by fire/rescue services

The following information must be visible on each extinguisher:

- Capacity
- Type of fire extinguisher
- Weight or volume of the fire extinguisher
- Date the fire extinguisher was checked, which must be no more than two years after either the date of filling or the date of the last check, or corresponding expiry date.

**97.02 Permitted fire extinguisher**

AFFF, FX G-TEC, Viro3, powder or any other fire extinguisher homologated.

**97.03 Minimum quantity**

- AFFF 2.4 [litres]
- FX G-TEC 2.0 [kg]
- Viro3 2.0 [kg]
- Zero 360 2.0 [kg]
- Powder 2.0 [kg]

#### **97.04 Pressure**

All extinguishers must be pressurised according in accordance with the manufacturer's instructions except for powder extinguishers with a pressure of 8 [bar] minimum and 13.5 [bar] maximum.

Furthermore, each extinguisher when filled with AFFF must be equipped with a mean of checking the pressure of the contents.

#### **97.05 Location**

At least one of the extinguishers must be easily accessible for the driver and the co-driver(s), seated normally with safety harnesses fastened and steering wheel in place.

All extinguishers must be adequately protected. The container may also be situated in the luggage compartment on condition that it is at least 300 [mm] from the outer edges of the bodypanel in all horizontal directions.

#### **97.06 Fixation**

It must be secured by a minimum of 2 screw-locked metallic straps and the securing system must be able to withstand a deceleration of 25 [g].

Furthermore, only quick-release metal fastenings, with metal straps, are accepted. The material of the securing system must operate within the -15°C to +80°C temperature range.

#### **97.07 Pipes**

Plastic pipes are prohibited and metal pipes are mandatory (unless specified otherwise).

#### **97.08 Triggering**

The means of triggering must be marked with a letter "E" in red inside a white circle of at least 10 [cm] diameter with a red edge.

#### **97.09 Nozzle**

The injector nozzles shall be free of sharp, sharp contact and its nozzles shall not be facing towards the occupants.

#### **97.10 Safety pin**

The extinguisher safety pin must be removed before starting for the selective sectors, easily visible and marked with a red tape of 20x200 [mm] (as shown below). This procedure will always be checked by the stewards at the start as well as at any other time during the qualifying sections. Failure to comply with this safety procedure will result in penalties to be set by the jury.



## **01.98 LIGHTS**

### **98.01 General**

The lighting equipment must be approved according to the ECE R38 road standard (or an equivalent or stricter standard from another country).

The lights must be constantly switched on during the running of the selective sections.

All the lighting equipment must be maintained in perfect working order throughout the entire duration of the competition.

### **98.02 Mandatory lights**

Each vehicle must be fitted with at least:

- 2 headlights (combined passing lights/headlights)
- 2 front lamps
- 2 rear lamps and number plate lighting
- 2 stop lights with a minimum surface of 50 [cm<sup>2</sup>]
- 4 flashing indicators, two at the front and two at the rear
- Distress lights (Warning)
- 2 additional red rear fog lamps twinned or placed side by side with a minimum height of 1.25 [m] from the ground attached to the outside of the vehicle.

### **98.03 Additional lights**

Two additional headlights may be fitted, provided that they are not situated more than 250 [mm] above the base of the windscreen.

They may be housed inside the supports of the external rear view mirrors.

The two headlamps and the additional lamps must be located in front of the axis of the front wheels, at a maximum height corresponding to that of the line of the bonnet/bottom of the windscreen (8 lamps maximum).

## **01.99 DRIVER AND CO-DRIVER EQUIPMENT**

The compulsory clothing equipment per occupant is: fire retardant suit, fireproof boots, hood and fireproof gloves.

The use of Head and Neck Support "HANS" or alternative homologated Frontal Head Restraint "FHR" system (including the helmet) is compulsory. It is not allowed to drive without the use of these mandatory elements the race.

### **99.01 Helmets**

The helmets must conform to the following standards:

- SNELL SA 2010
- SNELL SAH 2010
- SNELL SA 2015
- SNELL SA 2020
- SFI - 31.2A Full face design

---

## **Diagrams**



QUADS	GROUP G (2WD)	GROUP H (4WD)
Max. overall width (mm)	1.300	<del>1.400</del> <b>1.450</b>
Max. rim diameter (inches)	12	15
Max. seat height (mm)	950	<del>1.000</del> <b>1.100</b>
Handlebar width (min-max, mm)	650	800

max overall width 1.400 **1.450** mm (Group H)  
max overall width 1.300 mm (Group G)

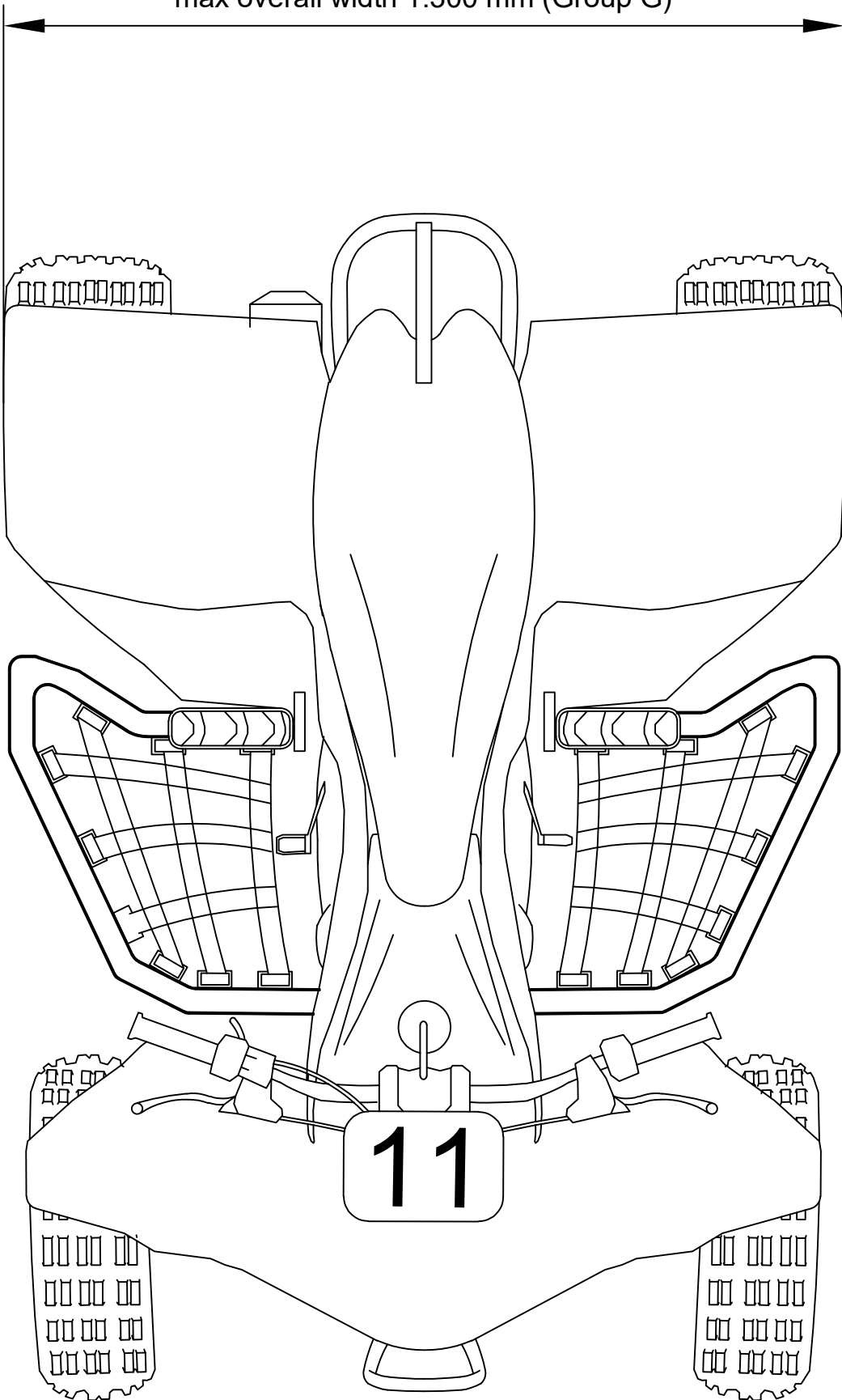

min 600 mm  
max 850 mm



11

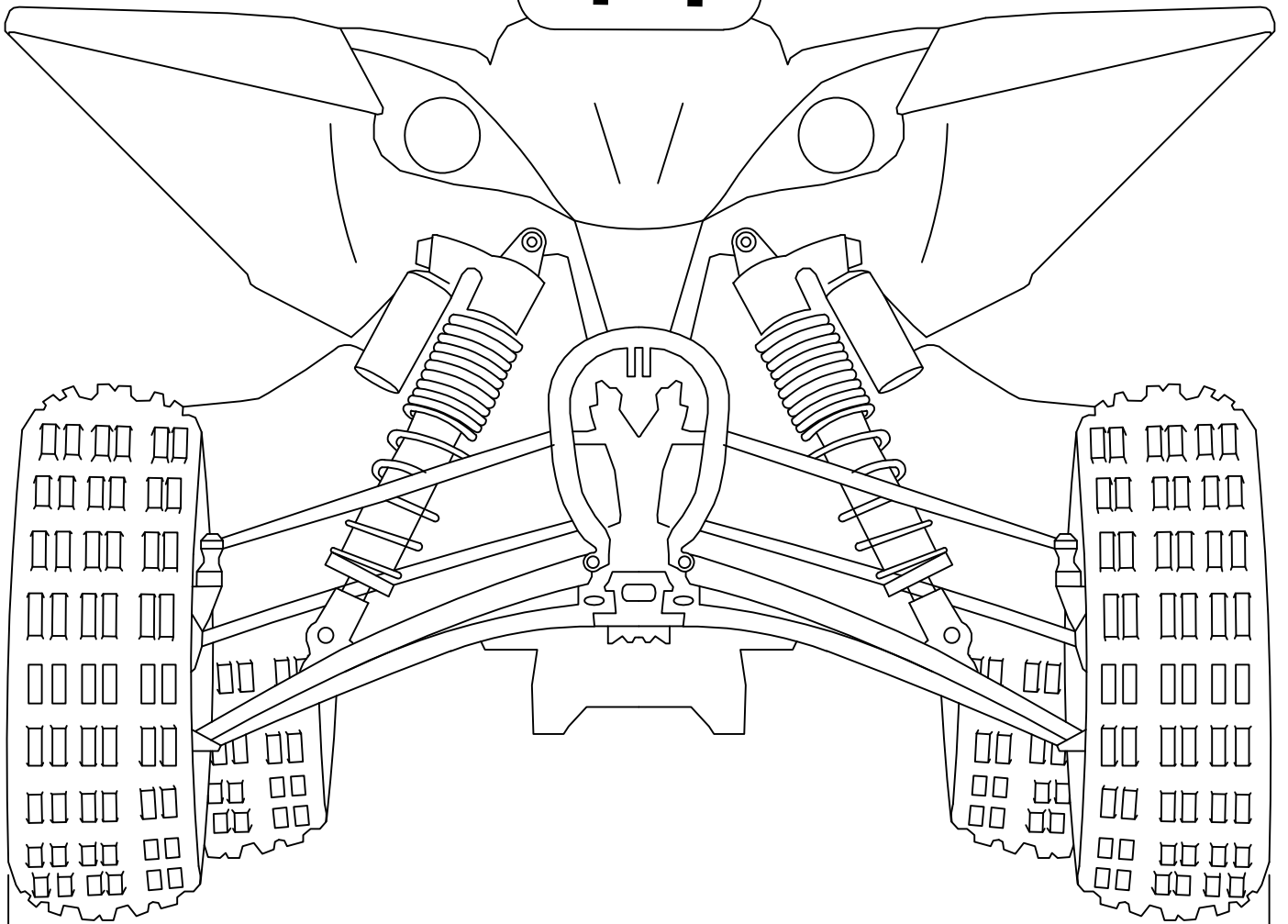

max overall width 1.400 **1.450** mm (Group H)  
max overall width 1.300 mm (Group G)

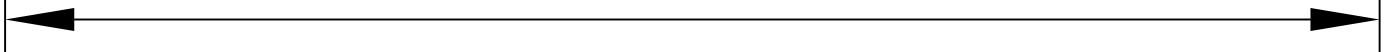

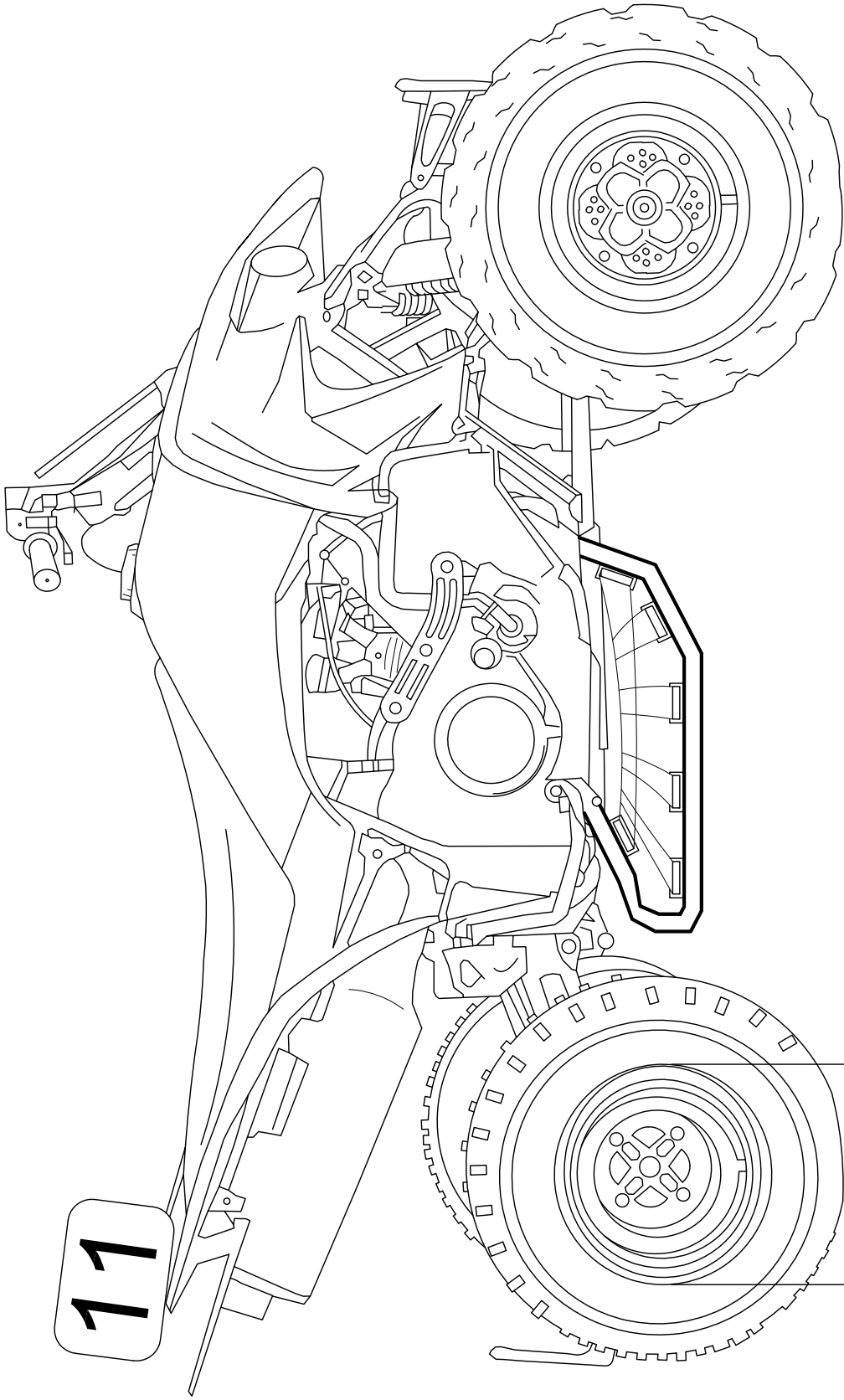

wheel rim  
diameter  
max 12" (Group G)  
max 15" (Group H)

## DIAGRAMME Q (suite)

**PROTECTIVE DEVICES (REAR) : sprocket and disc**  
**SYSTEMES DE PROTECTION (AR): couronne et disque**

- (1) Chain guard, mounting to a height corresponding to minimum 90°  
*Sabot inférieure remontant à la hauteur correspondant à 90° minimum*

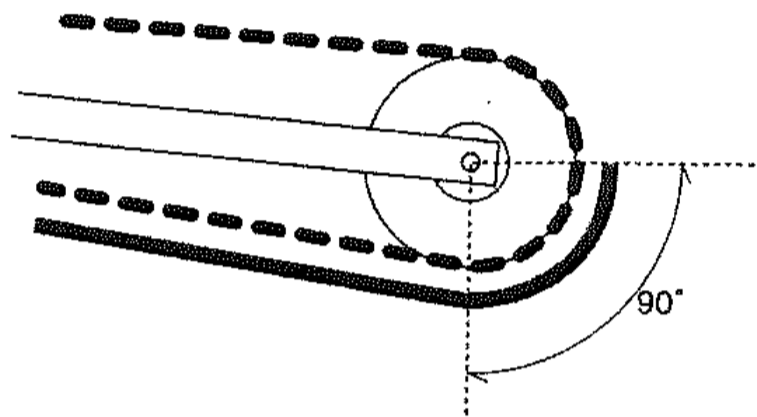

- (2) Chain guard + (3) protective guard  
*Sabot inférieure + (3) barre de protection*

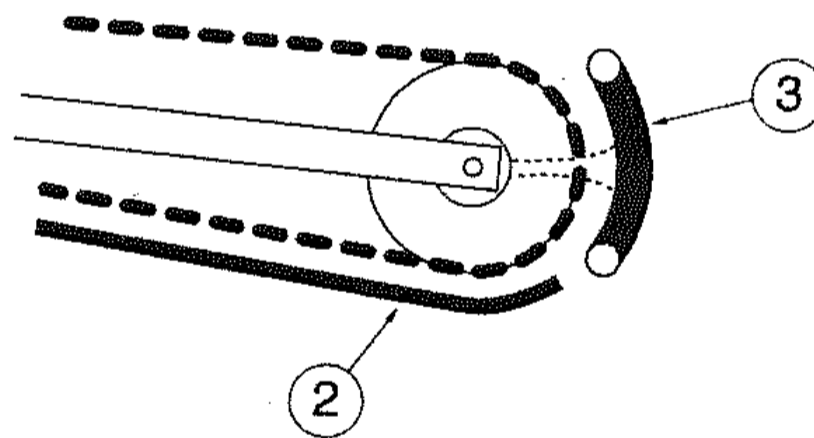

NUMBERS / NUMEROS

0

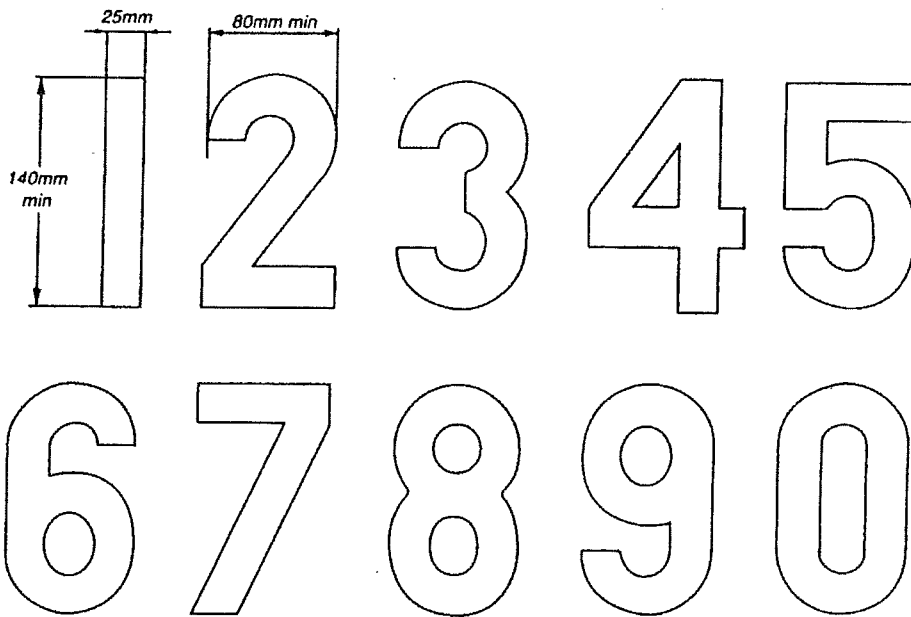
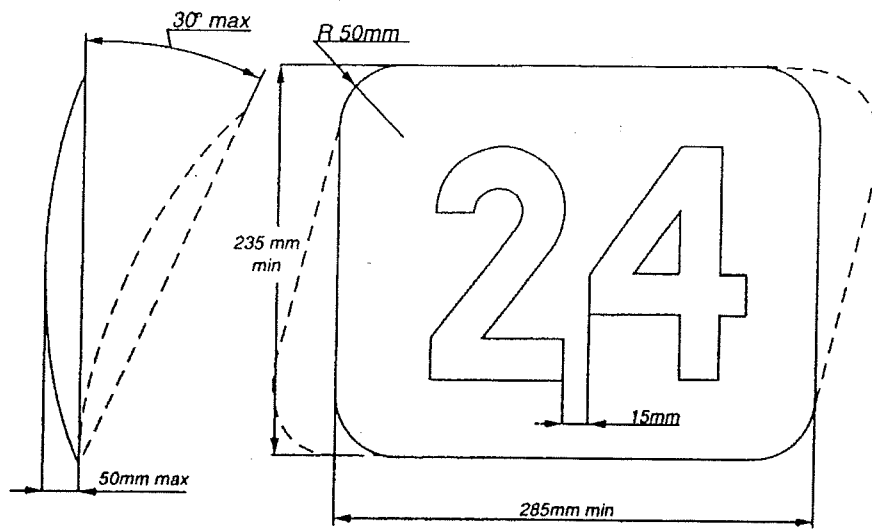

## **TEN FITTING TESTS FOR HELMETS** **DIX TESTS D'ADAPTATION POUR LES CASQUES**

1. *Obtain correct size by measuring the crown of the head*  
Avoir la bonne grandeur en mesurant le sommet de la tête
2. *Check there is no side to side movement*  
Vérifier qu'il n'y ait pas de déplacement d'un côté à l'autre
3. *Tighten strap securely*  
Serrer solidement la jugulaire
4. *With head forward, attempt to pull up back of helmet to ensure helmet cannot be removed this way*  
Tête en avant, essayer de soulever le casque pour s'assurer qu'il ne peut pas être enlevé de cette façon



5. *Check ability to see clearly over shoulder*  
Vérifier si vous pouvez voir clairement par-dessus l'épaule
6. *Make sure nothing impedes your breathing in the helmet and never cover your nose or mouth*  
S'assurer que rien ne gêne votre respiration dans le casque et ne jamais couvrir le nez ou la bouche
7. *Never wind scarf around neck so that air is stopped from entering the helmet. Never wear scarf under the retention strap*  
Ne jamais enrouler une écharpe autour du cou, car cela empêche l'air d'entrer dans le casque. Ne jamais porter d'écharpe sous la jugulaire
8. *Ensure that visor can be opened with one gloved hand*  
S'assurer que la visière peut être ouverte avec une main gantée
9. *Satisfy yourself that the back of your helmet is designed to protect your neck*  
S'assurer que l'arrière de votre casque a une forme telle qu'il vous protège la nuque
10. *Always buy the best you can afford*  
Toujours acheter le meilleur que vous pouvez vous offrir



FÉDÉRATION INTERNATIONALE  
DE MOTOCYCLISME

**FIM-MOTO.com**

11, ROUTE DE SUISSE | CH - 1295 MIES

[cti@fim.ch](mailto:cti@fim.ch)

65 790 07





FÉDÉRATION INTERNATIONALE  
DE MOTOCYCLISME

**FIM SOUND  
REGULATIONS  
2022**

# FIM Sound Regulation

## *Règlement FIM pour le son*

<b>Modifications log</b>		
<b>Updated</b>	<b>Applicable as from</b>	<b>Modified articles</b>
January 1 <sup>st</sup> 2021	01.01.2021	Creation
November 27 <sup>th</sup> 2021	01.01.2022	New value for Motocross
December 22 <sup>th</sup> 2021	01.01.2022	New 2025 values for SuperEnduro
<b>January 18<sup>th</sup> 2022</b>	<b>18.01.2022</b>	<b>A, D, E.6,</b>
<b>February 17<sup>th</sup> 2022</b>	<b>17.02.2022</b>	<b>E.3</b>
<b>February 22<sup>th</sup> 2022</b>	<b>22.02.2022</b>	<b>B, C</b>
<b>April 20<sup>th</sup> 2022</b>	<b>20.04.2022</b>	<b>A, C</b>
<b>May 17<sup>th</sup> 2022</b>	<b>17.05.2022</b>	<b>E.6</b>



## Table of Contents

- A. INTRODUCTION..... 3
- B. PREPARATION OF THE SOUND METER..... 4
- C. SET UP OF THE MEASUREMENT..... 4
- D. TEST PROCEDURE..... 8
- E. SOUND LIMITS..... 11
  - 1. TRIAL World Championships, Cups and Prizes ..... 11
  - 2. TRACK RACING World Championships, Cups and Prizes ..... 11
  - 3. ENDURO and ISDE World Championships, Cups and Prizes ..... 11
  - 4. SUPERENDURO World Championships, Cups and Prizes ..... 11
  - 5. CROSS-COUNTRY RALLIES & BAJAS World Championships and Cups..... 11
  - 6. MOTOCROSS World Championships, Cups and Prizes..... 12

## A. INTRODUCTION

In order to pursue the measures taken to reduce the sound level in favour of environment and in the framework of the 'RIDE QUIET' campaign, a new method for measuring the sound level called "2 metre max" is applied as from 2013 in all 'all-terrain' disciplines.

For the first World Championship event, all competitors' machines will be checked for sound level. After the first event, the machine of a 'wild card-' or 'one event' rider, will be checked for the sound level, as well as any other rider's machine on a random basis.

Excessively loud machines must always be checked, regardless of the participants' status.

The technical specifications and the resources to apply such a method, for the use of the technical stewards and officials, are outlined in the present article.

The "2 metre max" method shows a very good correlation between the sound power level (LwA) issued by motorcycles in full acceleration, and the maximum sound pressure levels measured at proximity of the same motorcycles, with engines at idle and quickly taken to their maximum rotational speeds.

The "2 metre max" method will consist in quantifying not only the sound level produced by the silencer of the exhaust, but the maximum global sound level achieved by the motorcycle when the engine rpm's are raised to the maximum engine speed, limited by a natural regulation (for 2 strokes) or rev limiters (for 4 strokes).

Only the sound levels measured with the "2 meter max" method will be considered by the technical stewards and by the Race Direction/Jury of the event to decide whether the motorcycle is in conformity with the maximum sound levels authorised.

### **For Motocross, Enduro/ISDE/SuperEnduro/HardEnduro:**

**Before the opening of the season, the manufacturers must declare to the FIM International Technical Commission (CTI) at [cti@fim.ch](mailto:cti@fim.ch) the maximum power rpm value of the engine of their motorcycles (in standard 'production' specification as sold on the market). The minimum threshold of rpm applied for each class for the sound control procedure will be defined and communicated by the FIM Technical Director.**

**No modification (in any possible way) of the original RPM channel is allowed. During the sound control, the engine must be able to reach its maximum admissible RPM level (meaning at least the minimum rpm set for each class by the FIM Technical Director according to the information provided by the manufacturers) in Neutral or In Gear position of the gearbox (at the discretion of the Sound Control Officer (SCO)).**

**Furthermore, all systems of dB-Killers must be either the original part delivered by the exhaust manufacturer or made in a safe and professional (well-engineered) way. In case of dispute, the decision of the FIM Technical Director will be final.**

## B. PREPARATION OF THE SOUND METER

**For all FIM championships and prizes, sound level meters must conform to the frequency response tolerance for Class 1 or Class 2 for nominal frequencies between 125Hz to 8000Hz, as stated by the IEC 61672-1:2013 subsection 5.5 standard.**

**All sound level meters must also conform to the tolerance for Class 1 or Class 2 for amplitude linearity, for it's specified class, as stated by the IEC 61672-1:2013 subsection 5.6 standard. IEC 61672 is a regulatory document, which covers specifications and qualification requirements for class 1 and class 2 sound level meters.**

~~For all FIM Championships and Prizes, all sound meters must have a frequency response According to IEC61672 Section 11 within a limit of plus or minus 2 [dB/A] from 125 to 8000 [Hz] at 94, 104 and 114 [dB/A].~~

Two sets of equipment must be available in case of failure of tachometer, sound level meter or calibrator during technical control.

Sound level measuring equipment must also include:

- a compatible calibrator, which must be used immediately before testing begins and always just prior to a re-test if a disciplinary sanction may be imposed;
- a tachometer.

The sound meter shall be prepared by applying the following procedure:

1. Activate the 'A' weighing
2. FAST time weighting must be activated
3. Select the highest range available (ex. 80~130 [dB])
4. Calibrate the sound meter according to the instructions, taking into account the incidence of the wind foam ball
5. Position the wind foam ball on the microphone
6. Activate the function MAX MIN – set on MAX

## C. SET UP OF THE MEASUREMENT

The sound levels will be measured with the microphone fixed on a tripod at a height of 1.35 m above the ground, in horizontal (levelled) position. It is helpful to have the microphone equipped with an extension cable to the sound meter.

For the place and position of the motorcycle, ensure that there are no solid obstacles within 10 m around the microphone.

Depending on the vehicle, the sound meter will be positioned:

**for Solo motorcycles:** at an angle of 45° from the longitudinal axis of the vehicle, on the exhaust side, at a distance of 2 m behind the vehicle (measured from the point where the centre of rear tyre touches the ground).

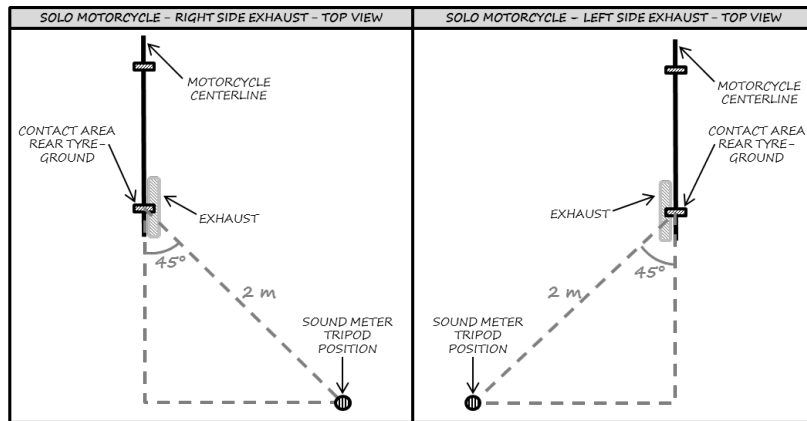

Figure 1 : Sound meter position for solo motorcycle

**for Solo motorcycles with 2 exhaust outputs:** at an angle of 45° from the longitudinal axis of the vehicle, on the side of the air intake, at a distance of 2 m behind the vehicle (measured from the point where the centre of rear tyre touches the ground). Note: if a central positioned air intake is used, both sides will be tested.

**for Snowmobiles:** at an angle of 90° from the longitudinal axis of the vehicle, on the side of the silencer, at a distance of 2 m next to the vehicle (measured from the silencer exit). For continuity of the measurement, use the handlebar as a reference to line up the machine with the microphone - the exhaust pipe is usually located on the right hand side of the machine and directly under the handlebar position. Note: the use of only one silencer is allowed for Snowmobiles.

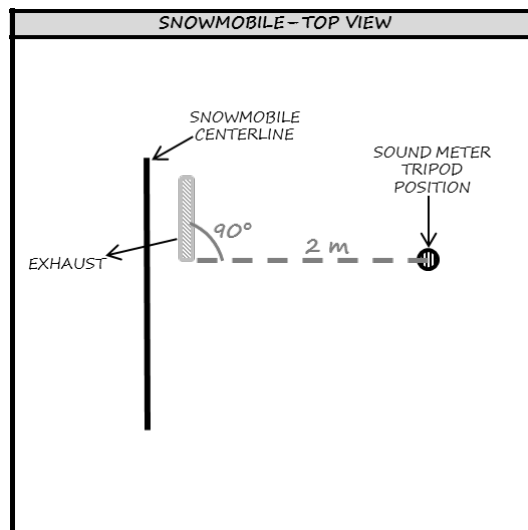

Figure 2: Sound meter position for solo snowmobile

**for Sidecars:** at an angle of 45° from the longitudinal axis of the vehicle, on the sidecar side, at a distance of 2 m behind the vehicle (measured from the point where the sidecar tyre touches the ground). If the exit of the silencer is closer to the motorcycle rear wheel, the reference point will be the contact point of the motorcycle rear wheel on the ground (as for Solo motorcycles).

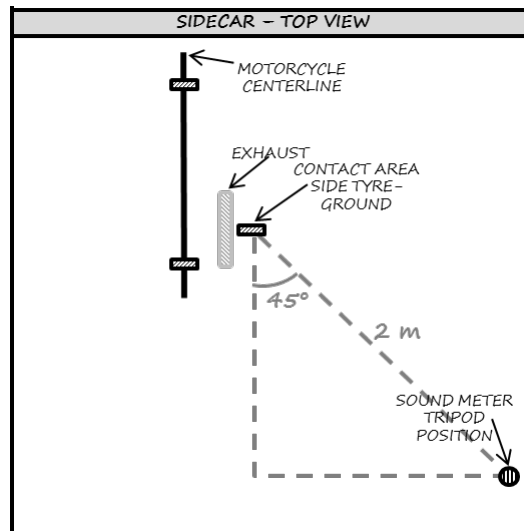

Figure 3: Sound meter position for sidecars

**for Quads:** at an angle of 45° from the median longitudinal axis of the vehicle, at a distance of 2 m behind the vehicle (measured from the point where the line drawn perpendicular to the rear axle touches the ground).

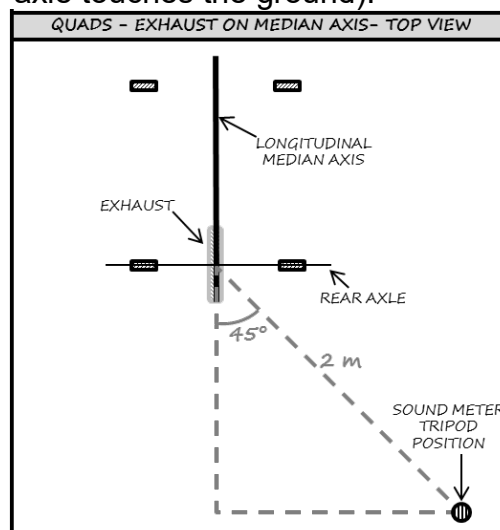

Figure 4: Sound meter position for quads

**for Quads with the exhaust moved out of the median axis:** at an angle of 45° from the exhaust axis, on the offset side, at a distance of 2 m behind the vehicle (measured from the point where the line drawn perpendicular to the rear axle touches the ground).

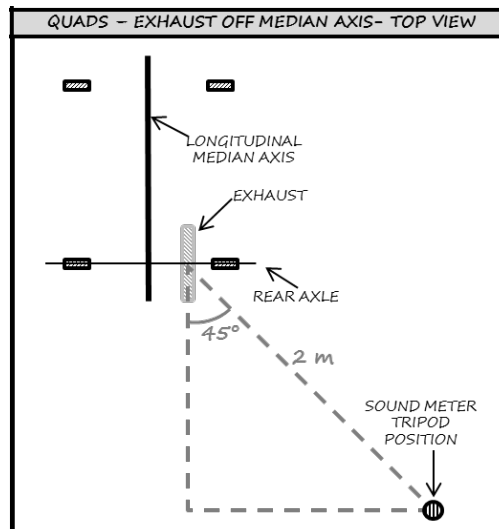

Figure 5: Sound meter position for solo motorcycle with exhaust moved out of the median axis

The sound level for engines with more than one silencer will be measured on each exhaust end.

Silencers fitted with adapters aiming to reduce the sound level shall be permanently fitted.

To make repetitive measurements, all motorcycles can be positioned into a small frame fixed on the ground, making sure to respect the 45° requirements. A squared frame helps the positioning of the motorcycle.

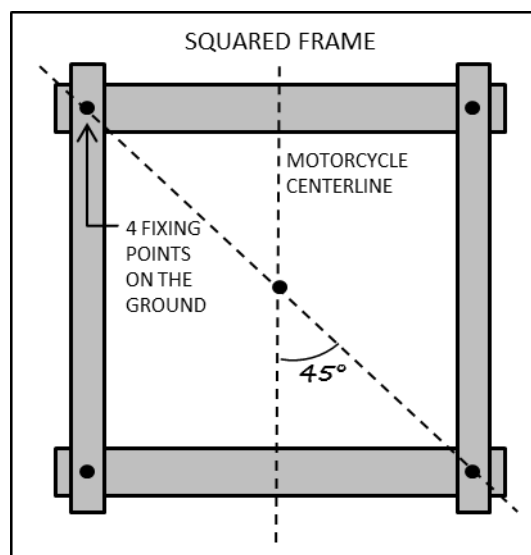

Figure 6 : Squared frame design

Vehicles which are not equipped with a gear box neutral must be placed on a stand.

It is preferred to make the tests on soft ground, not reverberating, i.e. grass or fine gravel.

In other than moderate wind, machines should face forward against the wind direction.



The ambient sound at the point of measurement must be minimum 15 [dB/A] less than the lowest FIM sound limit applied in each discipline.

**It is recommended to re-calibrate the sound meter before starting measurements and before putting the system away except when there has been any accident (physical impact to the equipment). In the event of an impact, the sound meter must be systematically re-calibrated before restarting any measurements.**

~~It is recommended to regularly re-calibrate the sound meter during the test day.~~

## D. TEST PROCEDURE

The Sound Control Officer (SCO) must be holder of a valid FIM Technical Stewards' license, come with good knowledge and experience of the sound control and application of the test method. The FMNR may propose the services from a special technician (acoustic engineer) if there is no FIM licenced Technical Steward available to act as SCO.

The SCO must have arrived in sufficient time for discussions with the Clerk of the Course/FIM Race Director and other Technical Officials in order that a suitable test site and testing procedure can be agreed. The SCO takes place next to the vehicle, opposite to the sound meter/microphone, in order not to screen or stand between the bike and the microphone.

A second technical steward can be present to help. The rider can also be present.

It is strongly advised that the technical steward(s) use earplugs, a headset or ear protectors.

The measurements **are** is made with motorcycle on its wheels, with a hot engine, **whatever in neutral gear position of in-gear position (at the discretion of the SCO)**. During the sound test, only the rider may sit on the vehicle in the normal riding position.

A rider or a mechanic, placed on the left side of the motorcycle, shall disengage the clutch.

The SCO (and not others) shall open the throttle as fast as possible (instantly, within 0.3 s) until "full open throttle", in order to reach the maximum rpm value ("max. rpm").

**For Motocross, Enduro/ISDE/SuperEnduro/HardEnduro, Cross-country rallies/Bajas and Track Racing motorcycles with no FIM homologated silencers,** the "max rpm" is the one defined by the ECU (for 4-stroke engines), or by a natural regulation (for 2-stroke engines).

When in doubt, it can be verified that such "max. rpm" value is higher than the rpm value at which the vehicle supplies its maximum power (kW) ("max. power rpm").

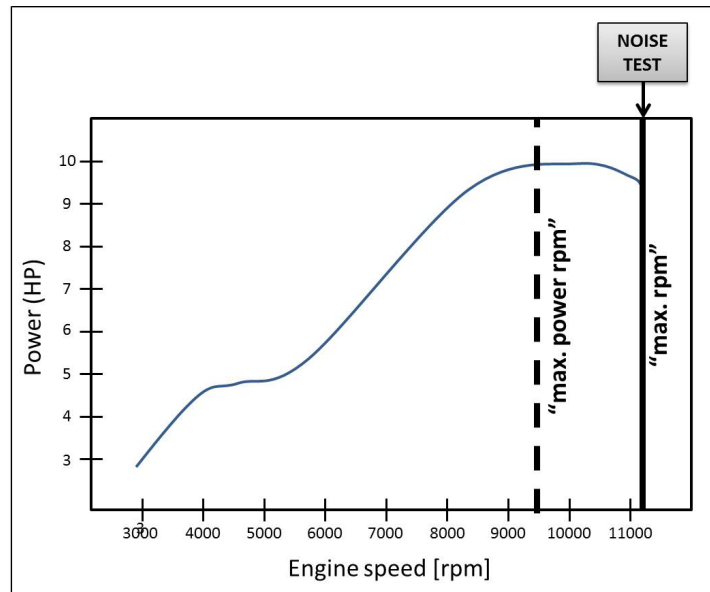

**For Trial**, the "max rpm" is established at 10000 ( $\pm 200$ ) rpm and obtained thanks to a dedicated "sound test" mapping of the internal ECU or an external one, purpose-made and connected in occasion of the test.

**For Track-Racing with FIM homologated silencers**, when sound tests are needed, the "max rpm" is established at 11000 ( $\pm 500$ ) rpm.

The SCO then keeps the engine at the "max. rpm" value for at least 1 s (or until there is an audible sign of over-revving the engine), during which the measurement is taken.

To conclude the test, the SCO releases the throttle quickly.

The maximum noise value (dB/A) registered during the measurement interval is then read on the sound meter and recorded. This noise value shall not be rounded down to the nearest whole number.

The noise value is then compared with the sound limits (see **Art. E**).

The noise test can be "**PASSED**" or "**NOT PASSED**":

**"PASSED"**: The sound test is considered "passed" if the recorded noise value is below or equal to the sound limits of **Art. E**. The silencer can then be marked by the SCO at the end of the test.

The silencer can be changed after verification under the conditions of Technical control.

The end opening of the silencer shall remain unmodified once it has been checked and marked.

**"NOT PASSED"**: The sound test is considered "not passed" if the recorded noise value is above the sound limits of **Art. E**.

In this case, the vehicle (with the same silencer) can be presented again, but for two more tests maximum. If the third test result is negative, the rider can present a different

or repaired silencer (in case the sound test was done before the race) will receive a penalty (in case the sound test was done during or after the race).

The sound meter is then reset by pushing on the side-line and armed by pushing on the side-line again.

**Notes:**

If the engine starts to misfire, close the throttle slightly and re-open the throttle.

If detonations appear, the measurement must be started again.

For vehicles without an engine rev. limiter, the throttle will have to be opened not more than 2 s or until there is an audible sign of over-revving the engine.

Even in case a vehicle has not exceeded the respective sound limit, if there is any doubt, the vehicle may be checked again.

If the vehicle is unable to reach the "max. power rpm" value, the vehicle shall be refused. Any attempt by a participant to prevent his engine from reaching the "max. power rpm" will be considered a breach of the rules.

In case the SCO doubts that the "max. power rpm" value (as declared by the manufacturers or previously obtained with the dyno test), he/she shall measure the engine speed with a tachometer connected to the spark.

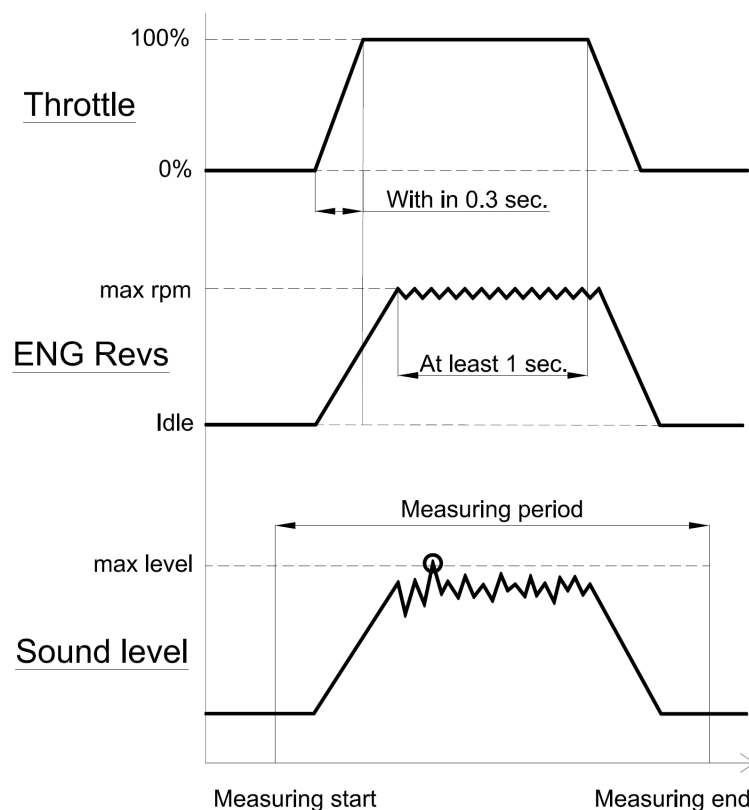

1. The Inspector shall open the throttle until full open throttle within 0.3 seconds.
2. And keep at the max rpm (at rpm limiter) at least 1 second. Then, release the throttle quickly.
3. The sound level is measured in the all period and the maximum level shall be recorded in any case. (automatically by the sound meter).

## E. SOUND LIMITS

Below are listed the maximal sound limits by category and by type of engine. No deductions for ambient temperature, pressure or altitude are allowed. If present, the values that have to be respected after the race take into account the degradation of the silencer (i.e. the limit is raised of 1 [dB/A]).

The measured noise value shall not be rounded down to the nearest whole number.

The values already take into account the accuracy of the method.

### 1. TRIAL World Championships, Cups and Prizes

Type of engine	Maximum Sound limit in [dB/A]	
	Before or during race	After race
2-stroke	103.0	104.0
4-stroke	105.0	106.0

Table 1 : Sound limit for Trial

### 2. TRACK RACING World Championships, Cups and Prizes

Type of engine	Maximum Sound limit in [dB/A]	
	Before or during race	
All	115.0	

Table 2: Sound limit for Track Racing

### 3. ENDURO, ISDE, SUPERENDURO, HARDENDURO World Championships, Cups and Prizes

Type of engine	Maximum Sound limit in [dB/A]	
	Before or during race	After race
All	114.0	115.0
<b>As of 2025</b>	<b>111.0</b> (Target <b>109.0</b> + 2.0 for the precision of the method)	<b>112.0</b> (Target <b>111.0</b> + 1.0 for the degradation of the silencer)

Table 3: Sound limit for

### 4. SUPERENDURO World Championships, Cups and Prizes

Type of engine	Maximum Sound limit in [dB/A]	
	Before or during race	After race
All	114.0	115.0

Table 4: Sound limit for SuperEnduro

### 5. CROSS-COUNTRY RALLIES & BAJAS World Championships and Cups

Type of engine	Maximum Sound limit in [dB/A]	
	Before or during race	After race
All	117.0	118.0

Table 5: Sound limit for Cross-Country Rallies

## 6. MOTOCROSS World Championships, Cups and Prizes

**As from 01/01/2022:**

MOTOCROSS World Championships, Cups and Prizes		
Discipline/Class	Maximum Sound limit (dB/A)	
	Before practice, during practice, before race	After race
MXGP, MX2, <b>Women MX</b>	114.0 <b>(Target 112.0 + 2.0 for the precision of the method)</b>	115.0 <b>(Target 114.0 + 1.0 for the degradation of the silencer)</b>
<b>Supercross (SX)</b>	114.0 <b>(Target 112.0 + 2.0 for the precision of the method)</b>	115.0 <b>(Target 114.0 + 1.0 for the degradation of the silencer)</b>
Sidecars: 2-stroke 4-stroke	114.0 114.0 <b>(Target 112.0 + 2.0 for the precision of the method)</b>	115.0 115.0 <b>(Target 114.0 + 1.0 for the degradation of the silencer)</b>
Junior MX: 2-stroke (65/85) 2-stroke (125) 4-stroke	111.0 <b>(Target 109.0 + 2.0 for the precision of the method)</b> 114.0 <b>(Target 112.0 + 2.0 for the precision of the method)</b>	112.0 <b>(Target 111.0 + 1.0 for the degradation of the silencer)</b> 115.0 <b>(Target 114.0 + 1.0 for the degradation of the silencer)</b>
Supermoto	114.0 <b>(Target 112.0 + 2.0 for the precision of the method)</b>	115.0 <b>(Target 114.0 + 1.0 for the degradation of the silencer)</b>
Snowcross	114.0 <b>(Target 112.0 + 2.0 for the precision of the method)</b>	115.0 <b>(Target 114.0 + 1.0 for the degradation of the silencer)</b>
Quad: 2-stroke 4-stroke	114.0 114.0 <b>(Target 112.0 + 2.0 for the precision of the method)</b>	115.0 115.0 <b>(Target 114.0 + 1.0 for the degradation of the silencer)</b>

Table 6: Sound limit for Motocross as from 01/01/2022

### **NOTES:**

- The values that have to be respected after the race take into account the degradation of the silencer (i.e. the limit is raised of 1 dB/A).
- The values already take into account the accuracy of the method.
- No deductions for ambient temperature, pressure or altitude are allowed.
- The measured noise value shall not be rounded down to the nearest whole number.



FÉDÉRATION INTERNATIONALE  
DE MOTOCYCLISME

**FIM-MOTO.com**

11, ROUTE DE SUISSE | CH - 1295 MIES

[cti@fim.ch](mailto:cti@fim.ch)

65 790 06



FÉDÉRATION INTERNATIONALE  
DE MOTOCYCLISME

**FIM FUELS  
REGULATIONS  
2022**

# FIM Fuels Regulation

## *Règlement FIM pour les essences*

<b>Modifications log</b>		
<b>Updated</b>	<b>Applicable as from</b>	<b>Modified articles</b>
January 1 <sup>st</sup> 2021	01.01.2021	Creation
November 27 <sup>th</sup> 2021	01.01.2022	Fuels specification for Cat. 1 and new fuels added
May 4 <sup>th</sup> 2022	04.04.2022	Art. D Fuels specification
<b>May 17<sup>th</sup> 2022</b>	04.04.2022	Art. D Fuels specification



**Table of Contents**

- A. Regular fuel..... 3
- B. RACE FUELS..... 4
  - 1. Conformed fuels .....4
  - 2. Appointed supplier(s) to event(s) .....4
- C. TESTING LABORATORY ..... 5
- D. FIM SPECIFICATIONS FOR UNLEADED FUELS OR MIXTURES OF UNLEADED FUELS, CATEGORY 1 ..... 6
- E. FIM SPECIFICATIONS FOR UNLEADED FUELS OR MIXTURES OF UNLEADED FUELS, CATEGORY 2 ..... 8
- F. FIM SPECIFICATIONS FOR MIXTURES OF UNLEADED FUEL(S) AND LUBRICANT ..... 10
- G. FUELS CONTROLS..... 11
  - 3. Sampling .....11
  - 4. Testing .....11
- H. FUEL SAMPLE DECLARATION FORM..... 14
- I. LIST OF APPROVED FUELS ..... 15

---

## **A.REGULAR FUEL**

If not specified in the Technical Rules of the Chamiponships, Cup or Prize or in the Supplementary regulation of the event, regular fuel coming from Public Fuel station can be used.

By regular fuel. It is to be understand fuel available at the fuel station with a fuel gun and with an Octane not more than 98.

## B. RACE FUELS

Fuel companies which supply “race” fuels (fuels other than those obtained at public pump stations) to participating teams/riders must test their fuel at against all the FIM specifications set out in **Art. D** of this regulation.

### 1. Conformed fuels

If the specifications of the fuel are in conformity to **Art. D** of this regulation, a certificate containing a test report and batch number will be issued to the fuel company.

The fuel company shall be able to provide a copy of such certificate to their client rider/teams before they take part in a race.

A list of fuels which are in conformity with FIM specifications are listed in **Art. I** of this regulation.

### 2. Appointed supplier(s) to event(s)

In the cases in which only fuel from the appointed supplier is permitted (for a specific event or the entire World Championship, Prize or Cup), the aforementioned fuel shall have been previously tested in a FIM appointed laboratory in order to test its conformity with the FIM specifications as set out in **Art. D** of this regulation:

- in case of conformity, a certificate of conformity (including test report and tested batch number) shall be available and **Art. I** of this regulation applies in case of controls for the riders/teams;
- in case the conformity is not achieved, the FMN of the organising country/the Organiser/the Promoter shall ask the FIM for a waiver in order to enable the use of fuel not corresponding to FIM specifications. If the waiver is granted, the riders/teams will be responsible for using the fuel provided without changing its composition. Controls may be carried out by FIM.

---

## C. TESTING LABORATORY

For question regarding the “race” fuels and/or the testing of the fuels please contact the aforementioned testing laboratory:

**Intertek (Schweiz) AG**

Analytical Testing - Fuel, Lubricants & Combustible  
Wagistraße 2  
8952 Schlieren  
Switzerland

Telephone: +41 43 433 78 10

Fax: +41 43 433 78 19

Email contact: [fimfuels@intertek.com](mailto:fimfuels@intertek.com).

## D. FIM SPECIFICATIONS FOR UNLEADED FUELS OR MIXTURES OF UNLEADED FUELS, CATEGORY 1

The following fuels specifications are valid for these FIM Competitions:

- MotoGP
- Moto2
- Moto3

The following properties shall be within the following thresholds (for each property, the relative test methods to be used for the measurement are indicated):

Property	Units	Min. <sup>1</sup>	Max. <sup>1</sup>	Test Methods <sup>2</sup>
Density at 15°C	[kg/m <sup>3</sup> ]	720.0	775.0	ASTM D4052
RON	-	95	102	EN ISO 5164
MON	-	85	90	EN ISO 5163
Oxidation stability	[min]	360		ASTM D525
Vapour pressure (DVPE)	[kPa]		90	EN 13016-1
Aromatics	% (V/V)		35.0	EN ISO 22854
Benzene	% (V/V)		1.0	EN ISO 22854
Diolefins total	% (m/m)		1.0	GC-MS HPLC
Existent Gum	[mg/100 mL]		5.0	EN ISO 6246
Lead	[mg/L]		5.0	<b>ICP-OES</b> or-EN 237
<b>Manganese</b>	<b>[mg/L]</b>		<b>1.0</b>	<b>ICP-OES</b>
Nitrogen	% (m/m)		0.2	ASTM D 4629
Olefins	% (V/V)		18.0	EN ISO 22854
Oxygen	% (m/m)		2.7	EN ISO 22854
Sulphur	[mg/kg]		10.0	ASTM D5453
Distillation:				EN ISO 3405
E at 70°C	% (V/V)	22.0	50.0	
E at 100°C	% (V/V)	46.0	71.0	
E at 150°C	% (V/V)	75.0		
Final Boiling Point	[°C]		210	
Residue	% (V/V)		2.0	
Copper Corrosion	Rating		Class 1	ISO 2160

Table 1 : Specifications and test methods (does not include the visual inspection)

<sup>1</sup> All reported min. and max. thresholds do not include the tolerance, which needs to be calculated in accordance with ISO 4259 and taken into account to correct the min. and max. thresholds

<sup>2</sup> In case of dispute the test method listed in **bold** will be the reference

Only the following oxygenates will be permitted:

- ◆Methanol
- ◆Ethanol
- ◆Iso-propyl alcohol
- ◆Iso-butyl alcohol
- ◆Methyl tertiary butyl ether
- ◆Ethyl tertiary butyl ether
- ◆Tertiary amyl methyl ether
- ◆Di-isopropyl ether
- ◆n-Propyl alcohol
- ◆Tertiary butyl alcohol
- ◆n-Butyl alcohol
- ◆Secondary butyl alcohol

In addition to these specifications, the appearance of the fuel, controlled by visual inspection must be clear, bright and free from solid matter and undissolved water.

The total of individual hydrocarbon components present at concentrations of less than 5% (m/m) must constitute at least 30% (m/m) of the fuel. The test method will be GC-FID (gas chromatography-flame ionisation detector) and/or GC-MS (gas chromatography-mass spectrometry).

The total concentration of naphthenes, olefins and aromatics classified by carbon number must not exceed the values given in the following table:

% (m/m)	C4	C5	C6	C7	C8	C9 +
Naphthenes	0	5	10	10	10	10
Olefins	5	20	20	15	10	10
Aromatics	-	-	1.2	35	35	30

**Table 2 : Naphtenes, Olefins and aromatics contents**

Bicyclic and polycyclic olefins are not permitted. The fuel must contain no substances which are capable of exothermic reaction in absence of external oxygen.

## E. FIM SPECIFICATIONS FOR UNLEADED FUELS OR MIXTURES OF UNLEADED FUELS, CATEGORY 2

The following fuels specifications are valid all FIM Competitions not included in Category 1.

The following properties shall be within the following thresholds (for each property, the relative test methods to be used for the measurement are indicated):

Property	Units	Min. <sup>3</sup>	Max. <sup>1</sup>	Test Methods <sup>4</sup>	
Density at 15°C	[kg/m <sup>3</sup> ]	720	785	EN ISO 12185	ASTM D4052
RON	-	95	102	EN ISO 5164	ASTM D2699
MON	-	85	90	EN ISO 5163	ASTM D2700
Oxidation stability	[min]	360		EN ISO 7536	ASTM D525
Vapour pressure (DVPE)	[kPa]		100	EN 13016-1	ASTM D5191
Aromatics	% (V/V)		35.0	EN ISO 22854	ASTM D6839
Benzene	% (V/V)		1.0	EN ISO 22854	ASTM D6839 or D5580
Diolfins total	% (m/m)		1.0	GC-MS	HPLC
Lead	[mg/L]		5.0	ICP-OES or-EN 237	AAS
Manganese	[mg/L]		2.0	ICP-OES	AAS
Nitrogen	% (m/m)		0.2	<b>ASTM D 4629</b>	ASTM 5762
Olefins	% (V/V)		18.0	EN ISO 22854	ASTM D6839
Oxygen (includes 10% ethanol allowance)	% (m/m)		3.7	<b>EN ISO 22854</b>	EN 13132 or elemental analysis
Sulphur	[mg/kg]		10.0	EN ISO 20846	ASTM D5453
Distillation:				EN ISO 3405	ASTM D86
E at 70°C	% (V/V)	20.0	52.0		
E at 100°C	% (V/V)	46.0	72.0		
E at 150°C	% (V/V)	75.0			
Final Boiling Point	[°C]		210		
Residue	% (V/V)		2.0		
Oxygenates:				<b>EN ISO 22854</b>	EN 13132
Methanol	% (V/V)		3.0		
Ethanol	% (V/V)		10.0		
Isopropanol	% (V/V)		12.0		
Isobutanol	% (V/V)		15.0		
tert-Butanol	% (V/V)		15.0		
Ethers (C5 or higher)	% (V/V)		22.0		
Others	% (V/V)		15.0		

Table 3 : Specifications and test methods (does not include the visual inspection)

<sup>3</sup> All reported min. and max. thresholds do not include the tolerance, which needs to be calculated in accordance with ISO 4259 and taken into account to correct the min. and max. thresholds

<sup>4</sup> In case of dispute the test method listed in **bold** will be the reference

In addition to these specifications, the appearance of the fuel, controlled by visual inspection must be clear, bright and free from solid matter and undissolved water.

The total of individual hydrocarbon components present at concentrations of less than 5% (m/m) must constitute at least 30% (m/m) of the fuel. The test method will be GC-FID (gas chromatography-flame ionisation detector) and/or GC-MS (gas chromatography-mass spectrometry).

The total concentration of naphthenes, olefins and aromatics classified by carbon number must not exceed the values given in the following table:

% (m/m)	C4	C5	C6	C7	C8	C9
						+
Naphthenes	0	5	10	10	10	10
Olefins	5	20	20	15	10	10
Aromatics	-	-	1.2	35	35	30

**Table 4 : Naphtenes, Olefins and aromatics contents**

Bicyclic and polycyclic olefins are not permitted. The fuel must contain no substances which are capable of exothermic reaction in absence of external oxygen.



## F. FIM SPECIFICATIONS FOR MIXTURES OF UNLEADED FUEL(S) AND LUBRICANT

The lubricant must not:

1. change the composition of the fuel fraction when added to the fuel
2. contain any nitro-compounds, peroxides or any other engine power boosting additives
3. contribute to an improvement in overall performance in any way
4. show a reduction in mass by evaporation of more than 10% (m/m) during the distillation up to 250°C (test method: simulated distillation GC)
5. contain more than 10% of anti-knock agents (lead, manganese, iron) (test method: ICP-OES).

Moreover, the following specifications are set for the mixture of unleaded fuel(s) and lubricant:

The following properties shall be within the following thresholds (for each property, the relative test methods to be used for the measurement are indicated):

Property	Units	Min.	Max. <sup>1</sup>	Test Methods	
Density at 15°C <sup>5</sup>	[kg/m <sup>3</sup> ]	690	815	EN ISO 12185	ASTM D4052
RON	-		102	EN ISO 5164	ASTM D2699
MON	-		90	EN ISO 5163	ASTM D2700

<sup>5</sup> For the density measurement, the min. and max. thresholds do include the tolerance

## G. FUELS CONTROLS

The FIM may require fuel controls, i.e. controls of the unleaded fuel, mixture of unleaded fuels or mixture of unleaded fuel and lubricant, used by riders/teams at events. These controls involve an initial sampling at the event and further testing in the FIM appointed laboratory.

### 3. Sampling

- 1) The FIM Technical Director (or the FMNR Chief Technical Steward when there is no FIM Technical Director appointed) is the sole official responsible for the sampling management and supervision.
- 2) Riders/teams selected for fuel controls are directed to proceed with their vehicles to the area that has been designated for this purpose.
- 3) The FIM Technical Director/FMNR Chief Technical Steward collects the fuel from the motorcycle by using only new sample containers and pipettes/hand pumps.
- 4) The fuel is transferred through the use of the pipette/hand pump directly from the fuel tank into three containers, denominated A, B and C. The containers are closed and sealed by the FIM Technical Director/FMNR Chief Technical Steward.
- 5) The FIM Technical Director/FMNR Chief Technical Steward fills in (in all its parts) and signs the Fuel Sample Declaration Form (see forms). The rider or a team representative also signs this Form, after verifying that all the information is correct.
- 6) The FIM Technical Director/FMNR Chief Technical Steward prepares an appropriate shipping box containing the collected A, B and C samples and a copy of the respective, signed, Fuel Sample Declaration Form. The box is then shipped to the FIM appointed laboratory by courier.

### 4. Testing

- 1) One or more properties to be checked (following the relevant testing method as per **Art. D, E or F**) are set by the FIM for each selected rider/team.
- 2) Sample A is the first sample to be tested by the FIM appointed laboratory.
- 3) Sample B can be used for a second analysis if required by the FIM. The test result of the A or B sample more favourable to the rider/team is taken into account. Costs for the shipping and testing of sample A and B are paid by FIM.
- 4) As soon as possible after completing the testing, the FIM appointed laboratory reports the test results directly to the responsible CTI Coordinator.
- 5) For negative cases (i.e. conformity of the tested property(ies) with the specification), the riders/teams concerned will be individually informed by the FIM in due course, copying the rider/team's FMN, the FIM Technical Director/FMNR Chief Technical Steward, the competent authority (e.g. Race Direction, International Jury), the CTI Director, the Director and Coordinator(s) of the sporting Commission concerned.

- 6) Only for positive cases following testing of sample A or B or A and B (i.e. non-conformity of one or more properties\*), the responsible CTI Coordinator notifies by electronic mail\* the rider/team concerned (including the testing results) and, 24 hours after, forwards the relevant information to the rider/team's FMN, the FIM Technical Director/FMNR Chief Technical Steward, the competent authority (e.g. Race Direction, International Jury), the CTI Director, the Director and Coordinator(s) of the sporting Commission concerned.

\*Note: The non-conformity of one property (except the Appearance) is sufficient for declaring non-conformity of the fuel or the mixture.

- 7) If the rider/team wishes to request a counter-expertise, he must notify the responsible CTI Coordinator by electronic mail\* accordingly, within 72 hours of receipt by the FIM of the delivery status notification pertaining to the notification of the test results to the rider/team.

- If a counter-expertise is requested, the sample dedicated to the counter-expertise is sample C and the test shall aim at checking the same property(ies) previously checked on sample A/B. The rider/team can request that sample C be tested at one of the available FIM appointed laboratories. Costs for shipping and testing of sample C are paid by the rider/team concerned.

Upon notification of the sample C results, the responsible CTI Coordinator notifies by electronic mail<sup>6</sup> the rider/team concerned (including the testing results) and forwards the relevant information to the rider/team's FMN, the FIM Technical Director/FMNR Chief Technical Steward, the competent authority (e.g. Race Direction, International Jury), the CTI Director, the Director and Coordinator(s) of the sporting Commission concerned.

- If no counter-expertise is requested within the time limit, the responsible CTI Coordinator forwards the relevant information by electronic mail\* the rider/team's FMN, the FIM Technical Director/FMNR Chief Technical Steward), the competent authority (e.g. Race Direction, International Jury), the CTI Director, Director and Coordinator(s) of the sporting Commission concerned.
- 8) The competent authority of the event concerned (e.g. Race Direction, International Jury) makes a decision based on the information received. The Coordinator of the sporting Commission concerned notifies the rider/team concerned regarding the decision by electronic mail\*.

The non-conformity of :

- A sample (in the cases B sample was not used) or
- B sample (in the cases A sample result was not conclusive) or
- A and B samples or

---

<sup>6</sup> The receipt of a delivery status notification will be deemed as proof of delivery

- A and B and C samples (in the cases B sample was used and a counter-expertise was requested) or
- A and C samples (in the cases B sample was not used and a counter-expertise was requested)

automatically results in the disqualification of the rider/team from the entire event.

No disqualification will be applied in case of conformity of sample C.

Furthermore, in any case, other penalties may be applied.

- 9) The rider/team has the right to appeal against the decision of competent authority of the event concerned (e.g. Race Direction, International Jury) in accordance with FIM Disciplinary and Arbitration Code applicable to the relevant discipline.

## H. FUEL SAMPLE DECLARATION FORM

 <span style="font-size: 1.5em; font-weight: bold; vertical-align: middle;">FIM Fuel Sample Declaration Form</span>																
Discipline																
IMN (xxx/xx)																
Rider/team's name																
Rider/team's number																
Rider/team's email or telephone number																
Team																
Vehicle's make																
Fuel's make and type																
Fuel origin (public station or race supplier)																
Fuel samples taken on date (dd/mm/yy)																
Fuel samples taken at (right before or after):																
<b>MOTOCROSS</b>  Practice <input type="checkbox"/> Qualifying race <input type="checkbox"/> Race 1 <input type="checkbox"/> Race 2 <input type="checkbox"/>	<b>TRIAL</b>  Day 1 <input type="checkbox"/> Day 2 <input type="checkbox"/>	<b>TRACK RACING</b>  Heat n°__ <input type="checkbox"/>	<b>ENDURO /ISDE</b>  Day 1 <input type="checkbox"/> Day 2 <input type="checkbox"/> Day n°__ <input type="checkbox"/>	<b>RALLIES /BAJAS</b>  Day 1 <input type="checkbox"/> Day 2 <input type="checkbox"/> Day n°__ <input type="checkbox"/>												
<table border="1" style="margin: auto; border-collapse: collapse;"> <thead> <tr> <th style="width: 10%;"></th> <th style="width: 10%;"></th> <th style="width: 80%;">Container seal n°</th> </tr> </thead> <tbody> <tr> <td style="text-align: center;"><b>Sample A</b></td> <td></td> <td></td> </tr> <tr> <td style="text-align: center;"><b>Sample B</b></td> <td></td> <td></td> </tr> <tr> <td style="text-align: center;"><b>Sample C</b></td> <td></td> <td></td> </tr> </tbody> </table>							Container seal n°	<b>Sample A</b>			<b>Sample B</b>			<b>Sample C</b>		
		Container seal n°														
<b>Sample A</b>																
<b>Sample B</b>																
<b>Sample C</b>																
<p>The above listed details refer to fuel samples taken from the fuel tank of the motorcycle specified.</p> <p><b>Sample A</b> is the first testing sample to be used by the FIM appointed laboratory</p> <p><b>Sample B</b> can be used for a second analysis if required by the FIM</p> <p><b>Sample C</b> is used if a counter-expertise is required by the rider/team.</p> <p>The serial numbers of the vial seals and the accuracy of the listed information have been verified.</p>																
Rider or team responsible name																
Rider or team responsible signature																
FIM Technical Director/ FMNR Chief Technical Steward name																
FIM Technical Director/ FMNR Chief Technical Steward signature																

## I. LIST OF APPROVED FUELS<sup>7</sup>

The fuels are listed in 2 categories:

- **Category 1:** MotoGP, Moto2, Moto3
- **Category 2:** All others

ENI					
N°	Sample incoming	Dossier	Batch/Lot	Reference	Category
2	19/01/12	112052/01	11/314	ENI SBK 2010 B	1   2
4	04/03/13	113085/02		Eni Blu super +	1   2
5	22/05/13	113085/03	13/002	Eni Blu super +	1   2
6	24/06/13	113085/04	13-131	SF-S	1   2
7	03/09/13	113085/05	PP130540	SF-S	1   2
8	20/01/14	114053/01	PP130711	Eni SF-S	1   2
9	31/01/14	114053/02	14/001	Eni Blu super +	1   2
10	10/02/15	115095/01#01	PP 140390	SF-S	1   2
11	02/03/15	115095/02	PTMG 01	Eni Blu Super+	1   2
12	09/03/15	115095/03#01	PP 150065	Eni SF S	1   2
13	15/02/16	116162/01	3391	SF-S 102	1   2
14	08/04/16	116162/02	E031-16	Eni SF-S	1   2

<sup>7</sup> The approved fuels listed here above are classified by manufacturer's alphabetical order to facilitate the reading

## Haltermann ETSP

N°	Sample incoming	Dossier	Batch/Lot	Reference	Category	
2	04/04/2013	113118/03	13-04/3015	ESC 1954		2
5	17/10/2013	113118/17	13-10/3157	TBX 4 EVO 2		2
6	17/10/2013	113118/18	13-10/3160	TBX 5 EVO 2		2
7	17/10/2013	113118/19	13-10/3161	XS EVO 2		2
8	14/03/2014	114152/01	14-03/3306	ESC LC5	1	2
9	04/08/2014	114152/02	14-07/3434	TBX 5 EVO 3		2
11	10/12/2015	115176/02	15-12/3865	ESC 1935	1	2
12	09/03/2016	116248/01	15-10/3833	IRF 102	1	2
13	29/08/2011	111045/05#01-02	BI-11-08/2595	ESC1933(APA001)	1	2
15	20/07/2016	116248/05	BI 16-07/4077	ESC STRAT 5	1	2
16	22/08/2016	116248/07	BI 16-08/4096	ESC LC6	1	2
17	11/01/2017	117019/06	BI 17-01/4185	ESC 1955 A		2
18	31/03/2017	117019/07	BI 17-03/4282	ESC LC6	1	2
19	14/07/2017	117019/08#01	BI 17-07/4362	ESC LC6	1	2
20	21/08/2018	118082/09	BI 18-08/4698	ESC LC6	1	2
21	15/03/2019	119076/04	BI 19-02/4826	ESC 1955		2
22	22/05/2019	119076/07	BI 19-05/4905	STRATO 5	1	2
23	06/06/2019	119076/09	BI 19-06/4921	ESC LC6	1	2
24	08/01/2020	120019/01	BI 19-12/5078	STRATO 5	1	2
25	10/01/2020	120019/02	BI 20-01/5084	STRATO 5	1	2
26	23/01/2020	120019/03	BI 20-01/5094	ESC 1955		2
27	30/06/2020	120019/04	BI 20-06/5155	STRATO 5	1	2
28	21/10/2020	120019/06	BI 20-10/5216	ESC 1937 C		2
29	30/10/2020	120019/07#01	BI 20-10/5214	STRATO 5	1	2
30	19/01/2021	121000/02	BI 21-01/5232	ESC 1955		2
31	09/04/2021	121000/03	BI 21-04/5289	STRATO 5	1	2
32	17/05/2021	121000/04	BI 21-05/5311	STRATO K2 B	1	2
<b>33</b>	<b>17/06/2021</b>	<b>121000/05</b>	<b>BI 21-06/5339</b>	<b>STRATO K2 B</b>	<b>1</b>	<b>2</b>
<b>34</b>	<b>12/08/2021</b>	<b>121000/06</b>	<b>BI 21-08/5374</b>	<b>STRATO K2 B</b>	<b>1</b>	<b>2</b>

## Lantmännen Aspen

N°	Sample incoming	Dossier	Batch/Lot	Reference	Category	
1	09/08/2017	117548/01	N/A/	NEW AR / ASPEN R	1	2

## Lukoil

N°	Sample incoming	Dossier	Batch/Lot	Reference	Category	
1	09/05/2016	116405/01	#1	Sporting gasoline	1	2
2	03/08/2016	116405/03	1330	Gasoline "SPORT"	1	2

## P1 Racing fuels

N°	Sample incoming	Dossier	Batch/Lot	Reference	Category	
1	11/01/2019	119033/01		SBX (P-RG-008-03)	1	2

## Panta

N°	Sample incoming	Dossier	Batch/Lot	Reference	Category	
3	27/05/2014	114219/01		K4	1	2
4	18/05/2015	115206/01			1	2
5	05/04/2016	116283/02	19/16	K4	1	2
6	15/03/2017	117183/01	01-17	Mtv4T01	1	2
7	15/03/2017	117183/02	22-17	K4	1	2
8	19/02/2020	120118/01	101	Panta MTV 4T-01		2
9	19/02/2020	120118/02	104	Panta K4	1	2
10	20/05/2020	120118/04	120	Panta K20	1	2

## Petronas

N°	Sample incoming	Dossier	Batch/Lot	Reference	Category	
1	15/11/2019	119415/01#01	M2A	Petronas Primax Pro-Race 1902M2A	1	2
2	11/11/2020	120374/01	M2A	Petronas Primax Pro-Race 2001M2A	1	2

## Race Republic

N°	Sample incoming	Dossier	Batch/Lot	Reference	Category	
1	11/02/2014	114101/01		P1 102 RX racing fuel	1	2

## Renegade

N°	Sample incoming	Dossier	Batch/Lot	Reference	Category	
1	17/04/2013	113179/01	14213	GP4-2/7	1	2



## Repsol

N°	Sample incoming	Dossier	Batch/Lot	Reference	Category	
					1	2
1	14/02/2012	112101/01		CTR-55-HRC	1	2
2	18/02/2013	113087/01		CTR-55 HRC	1	2
3	04/02/2014	114085/01		CTR-55 HRC	1	2
4	29/01/2015	115069/01		CTR-55-HRC	1	2
5	10/11/2015	115069/02#01		CTR-55-HRC	1	2
6	20/04/2016	116362/01	2016/01	CTR-19-MH	1	2
7	25/10/2016	116362/02		CTR-55 HRC	1	2
8	15/03/2017	117179/01	2017/01	CTR-19-MH	1	2
9	22/11/2017	117179/02		CTR-55-HRC	1	2
10	05/04/2018	118280/01		CTR-55-HRC	1	2
11	05/04/2018	118280/02		CTR-19	1	2
12	29/11/2018	118280/03		CTR-55-HRC	1	2
13	25/03/2019	119117/01		CTR-55	1	2
14	12/09/2019	119117/02	1-2019	CTR-19	1	2
15	01/09/2020	120024/01		CTR-55	1	2
16	09/03/2021	121153/01		CTR-19 MH	1	2
17	27/05/2021	121153/02		CTR-55 HRC	1	2

## Scuderia Braunschweig

N°	Sample incoming	Dossier	Batch/Lot	Reference	Category	
					1	2
Scu1	10/07/2019	119278/01	1907	SGR102		2

# Shell (1/2)

N°	Sample incoming	Dossier	Batch/Lot	Reference	Category	
1	25/05/2011	111008/06	PR4414	PR4414 - Ducati Fuel G2	1	2
2	09/02/2012	112091/01	PR4666	Ducati Fuel Duc 3	1	2
3	13/02/2012	112091/02	PR4670	RD 05-08-Fuel	1	2
4	13/03/2012	112091/03	PR4696	Ducati Fuel Duc 10	1	2
5	21/03/2012	112091/05	PR4719	Racing Fuel - RT	1	2
6	27/03/2012	112091/06	PR4722	Racing Fuel - BF	1	2
7	13/06/2012	112091/07	PR4826	Ducati Fuel DUC 10	1	2
8	28/01/2013	113058/01	PR5050	Ducati Fuel Duc 10	1	2
9	20/02/2013	113058/02	PR5088	Ducati Fuel Duc 10	1	2
10	14/06/2013	113058/03	PR5193	Ducati Fuel Duc 10	1	2
11	06/12/2013	113058/04	PR5383	Ducati Fuel Duc 10	1	2
12	27/12/2013	113058/05	PR5438	Ducati Fuel Duc 12	1	2
13	10/03/2014	114140/01	PR5498	Ducati Fuel Duc 12	1	2
14	04/06/2014	114140/06	PR5640	Ducati Fuel Duc 12	1	2
15	22/08/2014	114140/11	PR5803	Ducati Fuel Duc 12	1	2
17	27/11/2014	114140/13	PR5941	Ducati Fuel Duc 12	1	2
18	16/02/2015	115104/01	PR6084	Ducati Fuel Duc 30	1	2
19	07/05/2015	115104/02	PR6198	Ducati Fuel Duc 30	1	2
20	01/06/2015	115104/03	PR6235	Ducati Fuel Duc 30	1	2
21	27/07/2015	115104/04	PR6293	Ducati Fuel Duc 30	1	2
22	23/10/2015	115104/05	PR6395	Ducati Fuel Duc 30	1	2
23	13/01/2016	116063/01	PR6456	Ducati Fuel Duc 30	1	2
24	21/04/2016	116063/02	PR6605	Ducati Fuel Duc 30	1	2
25	02/08/2016	116063/05	PR6697	Ducati Fuel Duc 50	1	2
26	09/09/2016	116063/06	PR6730	Ducati Fuel Duc 51	1	2
27	17/10/2016	116063/07	PR6795	Ducati Fuel Duc 30	1	2
28	20/02/2017	117138/01	PR6914	Ducati Fuel Duc 50	1	2
29	08/05/2017	117138/02	PR6980	Ducati Fuel Duc 30	1	2
30	08/05/2017	117138/03	PR6989	Ducati Fuel Duc 53	1	2
31	09/06/2017	117138/04	PR7042	Ducati Fuel Duc 53	1	2
32	11/07/2017	117138/05	PR7074	Ducati Fuel Duc 50	1	2
33	04/12/2017	117138/06	PR7219	Ducati Fuel Duc 53	1	2
34	06/02/2018	118039/01	PR7275	Ducati Fuel Duc 30	1	2
35	09/02/2018	118039/02	PR7308	Ducati Fuel	1	2
36	09/02/2018	118039/03	PR7313	Ducati Fuel	1	2
37	20/02/2018	118039/04	PR7324	Ducati Fuel	1	2
38	27/02/2018	118039/05	PR7331	Ducati Fuel	1	2
39	21/03/2018	118039/06	PR7361	Ducati Fuel	1	2
40	16/07/2018	118039/07	PR7519	Ducati Fuel	1	2
41	25/07/2018	118039/08	PR7531	Ducati Fuel	1	2
42	14/08/2018	118039/09	PR7557	Ducati Fuel	1	2
43	16/11/2018	118039/10	PR7652	Ducati Fuel	1	2
44	30/01/2019	119075/01	PR7674	Shell V-Power	1	2
45	13/05/2019	119075/02	PR7832	Ducati Fuel	1	2
46	05/08/2019	119075/03	PR7917	Ducati Fuel	1	2
47	24/12/2019	119075/04	PR8101	Ducati Fuel	1	2
48	29/01/2020	120070/01#01	PR8129	Ducati Fuel	1	2
49	06/07/2020	120070/03	PR8283	Ducati Fuel	1	2
50	10/08/2020	120070/04	PR8329	Ducati Fuel	1	2

## Shell (2/2)

N°	Sample incoming	Dossier	Batch/Lot	Reference	Category	
51	14/08/2020	120070/05#01	14/08/2020	Ducati Fuel	1	2
52	31/03/2021	121194/01#01	PR8569	Ducati Fuel	1	2
53	18/05/2021	121194/02	PR8672	Ducati Fuel		2
54	07/06/2021	121194/03	PR8694	Ducati Fuel	1	2
55	26/07/2021	121194/04	PR8749	Ducati Fuel	1	2
56	05/08/2021	121194/05	PR8820	Ducati Fuel	1	2

## Showa Shell Sekiju

N°	Sample incoming	Dossier	Batch/Lot	Reference	Category	
1	10/07/2014	114266/01			1	2

## Slovakia Ring Agency

N°	Sample incoming	Dossier	Batch/Lot	Reference	Category	
1	20/03/2018	118224/01		OMV MaxxMotion 100+	1	2

## Soldà Vladimiro SpA (Wladoil)

N°	Sample incoming	Dossier	Batch/Lot	Reference	Category	
1	27/05/2016	116466/01	16/05/04	WLADOGAS BB1	1	2

# Total (1/3)

N°	Sample incoming	Dossier	Batch/Lot	Reference	Category	
1	30/12/2011	111083/18	WSBK-FIM, 01220581U	MOTO 4TMAX, O1220561U	1	2
2	09/01/2012	112012/01	O1220559U	YMH48	1	2
3	01/03/2012	112012/03	P0120617U	MIT46	1	2
4	01/03/2012	112012/04	P0220640U	MIT42	1	2
5	07/03/2012	112012/05	P0220643U	Moto 4SGP	1	2
6	30/04/2012	112012/07	P0420713U	Moto 4SGP	1	2
7	31/05/2012	112012/08	P0520750U	YMH48	1	2
8	27/06/2012	112012/09	P0520756U	MIT 46	1	2
9	12/07/2012	112012/10	P0720847U	SPB MOTO 4T MAX	1	2
10	13/08/2012	112012/11	P0620824U	ESSENCE SP MIT 43	1	2
11	07/01/2013	113014/01	P1221076U	SPB HRC41	1	2
12	07/01/2013	113014/02	P1221064U	MOTO 4SGP	1	2
13	17/01/2013	113014/03 113014/07	P1221069U T0321199U	MOTO 4TMAX WSBK	1	2
14	17/01/2013	113014/04	P1221066U	YMH48	1	2
15	17/03/2013	113014/05	T0221130U	SP YMH48	1	2
16	17/03/2013	113014/06	T0221129G	MOTO 4TMAX	1	2
17	10/05/2013	113014/08	T0321200U	MOTO 4SGP	1	2
18	09/09/2013	113014/09	T0821415U	SPB HRC41	1	2
19	15/10/2013	113014/10	T0921520U	SPB HRC41	1	2
20	13/11/2013	113014/11 113014/12	T1021523U T1021523U	SZK34 SP 4THRC33	1	2
22	17/12/2013	113014/16	T1121601U	MOTO 4T YMH48	1	2
23	06/01/2014	114015/01	T1121610U	SPB HRC41	1	2
24	03/02/2014	114015/02	PCT120371U PCQ010325U	SPB MOTO 4TMAX WSBK-FIM	1	2
25	11/02/2014	114015/03	PCQ010240U	SPB MOTO 4SGP	1	2
26	20/02/2014	114015/04	PCQ010236U	SP YMH48	1	2
27	14/04/2014	114015/05	PCQ040134G PCQ040211	SPB MOTO 4TMAX WSBK-FIM T50L	1	2
28	19/05/2014	114015/06	PCQ040116U	SPB HRC41	1	2
29	23/05/2014	114015/07	PCQ030232G PCQ050131G	SPB MOTO 4TMAX WSBK-FIM	1	2
30	02/06/2014	114015/08	PCQ050143U	SP YMH48	1	2
31	27/06/2014	114015/09	PCQ060147U	SPB MOTO 4SGP	1	2
32	31/07/2014	114015/13	PCQ070079U	SPB HRC41	1	2
33	22/08/2014	114015/15	PCQ060192G PCQ080194G	SPB MOTO 4TMAX WSBK-FIM	1	2
34	23/09/2014	114015/22	PCQ090232U	SZK34	1	2
35	16/12/2014	114015/23	PCQ100382U	SPB HRC41	1	2
36	07/01/2015	115017/01	PCQ120216U	SZK34	1	2
37	14/01/2015	115017/02	PCQ120252U	YMH48	1	2
38	18/02/2015	115017/03	PCZ020169U	MOTO 4SGP	1	2
39	10/07/2015	115017/04	PCZ060345 PCZ060291	MOTO 4TMAX WSBK-FIM	1	2
40	11/08/2015	115017/05	PCZ070267U	YMH48	1	2
41	14/09/2015	115017/06	PCZ090168U	HRC41	1	2
42	30/09/2015	115017/07	PCZ090304U	Moto 4SGP	1	2

## Total (2/3)

N°	Sample incoming	Dossier	Batch/Lot	Reference	Category	
43	22/12/2015	115017/08	PCZ110339U	SZK34	1	2
44	22/12/2015	115017/09	PCZ090305U	SPB MOTO 4SGP	1	2
45	22/12/2015	115017/10	PCZ120176G	MOTO 2 FIM	1	2
46	12/01/2016	116060/01	PCZ120373U	MOTO 4SGP	1	2
47	23/02/2016	116060/02	PCS020149U	YMH48	1	2
48	03/03/2016	116060/03	PCS020288U	MOTO 4SGP	1	2
49	31/03/2016	116060/04	PCS030155U	SZK34	1	2
50-51	05/04/2016	116060/05	PCS030327 + PCS030328	MOTO 4T MAX + WSBK-FIM	1	2
52	10/05/2016	116060/06	PCS040330U	SPB MOTO 4SGP	1	2
53	14/06/2016	116060/07	PCS050314U	MITS46	1	2
54	22/07/2016	116060/08	PCS060244U	SZK34	1	2
55	27/07/2016	116060/09	PCS070136G	SPB MOTO 4SGP	1	2
56	31/08/2016	116060/10	PCS080240U	SBP HRC41	1	2
57	08/09/2016	116060/11	PCS080332	SPB MOTO 4T MAX	1	2
58	08/09/2016	116060/11	PCS080333	WSBK-FIM	1	2
59	14/12/2016	116060/12	PCS110336U	HRC41	1	2
60	30/12/2016	117012/01	PCS1202616U	SPB MOTO 4SGP	1	2
61	30/12/2016	117012/02	PCS120465U	SZK 34	1	2
62	03/02/2017	117012/03	PCE010121G	ELF MOTO 2 FIM	1	2
63	03/02/2017	117012/03	PCE010121G	TOTAL MOTO 2 FIM	1	2
64	24/02/2017	117012/04	PCE010368U	SPB MOTO 4T MAX	1	2
65	24/02/2017	117012/04	PCE020215	WSBK-FIM	1	2
66	09/03/2017	117012/05	PCE0201799G	Moto 4SGP	1	2
67	09/03/2017	117012/06	PCE030052U	YMH48	1	2
68	04/05/2017	117012/07	PCE040329U	SZK46	1	2
69	18/05/2017	117012/08	PCE040292U	MOTO 4SGP	1	2
70	26/05/2017	117012/09	PCE040261U	HRC41	1	2
71	07/06/2017	117012/10	PCE050235U	SZK34	1	2
72	22/09/2017	117012/11	PCE080094U	MITS46	1	2
73	06/10/2017	117012/12	PCE090297U	MOTO 4SGP	1	2
74	15/12/2017	117012/13	PCE110351U	SZK34	1	2
75	01/02/2018	117012/14	PCE120271U	APL03	1	2
76	01/02/2018	118013/01	PCE120284U	HRC41	1	2
77	05/02/2018	118013/02	PCE120376U	MOTO 4SGP	1	2
78	08/02/2018	118013/03	PCE120378U	YMH48	1	2
79	08/02/2018	118013/04	PCH010065G	ELF MOTO 2 FIM	1	2
80	09/04/2018	118013/05	PCH030291G	ELF MOTO 2 FIM	1	2
81	30/04/2018	118013/07	PCH040203U	MOTO 4SGP	1	2
82	09/05/2018	118013/08	PCH050144U	APL03	1	2
83	09/05/2018	118013/09	PCH050163P	APL03	1	2
84	04/06/2018	118013/10	PCH050294U	SZK46	1	2
85	29/06/2018	118013/11	PCH050362U	Moto 4SGP	1	2
86	08/08/2018	118013/16	PCH080204U	APL03	1	2
87	16/08/2018	118013/17	PCH080148U	YMH48	1	2
88	16/08/2018	118013/17	PCH080487	APL02	1	2
89	12/09/2018	118013/18	PCH080141U	Moto 4SGP	1	2
90	10/12/2018	118013/19	PCH100529U	Moto 4SGP	1	2

## Total (3/3)

N°	Sample incoming	Dossier	Batch/Lot	Reference	Category	
91	09/01/2019	119022/01	PCH110243G	ELF MOTO 2 FIM	1	2
92	01/02/2019	119022/02#01	PCF010098G	ESSENCE SPB MOTO 4SGP	1	2
93	26/02/2019	119022/05	PVF020242U	Essence SP YMH48	1	2
94	13/03/2019	119022/06	PCF020373U	SZK48	1	2
95	17/04/2019	119022/08	PCF040238U	APL02	1	2
96	29/05/2019	119022/09	PCF050286U	YMH48	1	2
97	11/06/2019	119022/10	PCF050313U	MOTO 4SGP	1	2
98	18/07/2019	119022/11	PCF070179U	MOTO 4SGP	1	2
99	05/08/2019	119022/12	PCF070373U	MOTO 4T MAX	1	2
100	19/08/2019	119022/13	PCF070414U	APL02	1	2
101	19/08/2019	119022/14	PCF080079	WBSK-FIM	1	2
102	10/12/2019	119022/15	PCF120187U-GC	YMH48	1	2
103	13/12/2019	119022/16	PCF120134G	MOTO 4SGP	1	2
104	27/12/2019	119022/17	PCF110267U	MITS46	1	2
105	09/03/2020	120050/12	PCV020291U	ELF 4S FIM EVOX		2
106	09/03/2020	120050/13	PCV020392U	APL05	1	2
107	25/05/2020	120050/14#01	PCV040144U	Essence SPB YMH48	1	2
108	21/07/2020	120050/15	PCV070214U	ELF 4S FIM EVOX	1	2
109	31/07/2020	120050/17	PCV070412	APL05	1	2
110	11/08/2020	120050/18	PCV070408G	ELF MOTO2 FIM	1	2
111	25/08/2020	120050/19	PCV070431U	ELF 4S FIM EVOX	1	2
112	30/09/2020	120050/20	PCV090122U	Essence SP YMH48	1	2
113	13/11/2020	120050/21	PCV100391U	ELF 4S FIM EVOX		2
114	22/02/2021	121131/01	PCU020095U	Essence SPB MOTO 4SGP	1	2
115	22/02/2021	121131/02	PCU020136U	Essence SP YMH48	1	2
116	24/03/2021	121131/04	PCU030021G	ELF MOTO 2 FIM	1	2
117	26/04/2021	121131/07	PCU040311U	ELF 4S FIM EVOX		2
118	14/05/2021	121131/08	PCU040289	APL05	1	2
119	06/07/2021	121131/13	PCU060378U	Essence SP YMH48	1	2
120	/2021	121131/14#01	PCU050322U	Essence SPB MOTO 4SGP	1	2
121	22/07/2021	121131/15	PCU070208U	ELF 4S FIM EVOX		2

## VP Racing Fuels

N°	Sample incoming	Dossier	Batch/Lot	Reference	Category	
1	28/05/2015	115205/01	128/15	VP Moto		2
2	31/08/2018	118649/01	242/18	VP Moto		2
3	11/04/2019	119078/03	#053/19	VP MGP	1	2



FÉDÉRATION INTERNATIONALE  
DE MOTOCYCLISME

**FIM-MOTO.com**

11, ROUTE DE SUISSE | CH - 1295 MIES

[cti@fim.ch](mailto:cti@fim.ch)

65 790 06