



FÉDÉRATION INTERNATIONALE  
DE MOTOCYCLISME

# FIM FLAT TRACK APPENDICES

## 2022



### **IMPORTANT NOTE**

Whilst the CCP will make every effort to complete the 2022 championships in accordance with these regulations, it has to be understood and accepted that due to the severe health crisis encountered since 2020, some regulations may be subject to change possibly last minute due to changing circumstances and government requirements.

<b>SPORTING RULES</b>		
1	General	4
1.1	Titles	4
1.2	Definitions	4
1.3	Supplementary regulations	4
1.4	Dates of the meetings	4
1.5	Responsibility for organisation	5
2	Officials	5
3	Riders	10
3.1	Medical certificate and examination	10
3.2	Age of the riders	11
3.3	Licences	11
3.4	Entries	11
3.5	Fines	11
3.6	Starting numbers	12
3.7	Riding numbers	12
3.8	Permanent	12
3.9	Wild card	13
3.10	Substitutes	13
3.11	Signing on	13
3.12	Health and safety	13
4	Tracks	13
5	Motorcycles	13
5.1	Artificial heating tyres	13
5.2	Number of motorcycles	13
6	Practices	14
7	Race	14
7.1	Direction of races	14
7.2	Punctuality in starting	14
7.3	Delaying the start	14
7.4	Starts	14
7.5	Race stoppage	15
7.6	Re-staging / abandonment of a meeting	15
7.7	Faulty starting gate	15
7.8	Starting assistance	15
7.9	Leaving the track	15
7.10	Foul or dangerous riding	15
7.11	Time limit	16
7.12	Finish of a heat	16
7.13	False finish	16
7.14	Rerun heat	16
8	Results	16
8.1	Calculation of the results	16
8.2	Riders' scores	17
9	Race format	17
9.1	Points system	18
9.2	Ties	18

9.3	Run off heats	1/
9.4	Communication of the results	19
9.5	Alteration of the results	19
9.6	Price giving ceremony	19
9.7	FIM Awards	19
10	Alcohol/anti doping controls	19
11	Protests/penalties	19
12	Expense reimbursement	20
<b>TECHNICAL RULES</b>		
1	Equipment	21
1.1	Clothing / protection	21
1.2	Footwear	21
1.3	Helmet	21
1.4	Gloves	21
1.5	Google	22
2	Construction	22
3	Definition of a solo frame	23
4	Starting device	23
5	Fuel tank	23
6	Open transmission guards	23
7	Exhaust pipe/silencer	23
8	Handlebars	24
9	Control levers	24
10	Footrest	24
11	Mudguards	25
12	Streamlining	25
13	Suspension	25
14	Wheels, rims and tyres	25
15	Capacity	25
16	Supercharging	26
17	Telemetry	26
18	Number plates	26
19	Numbers sashes	26
20	Ignition cut out switches	27
21	Breaks	27
22	Fuel	27
23	Carburation	30
24	Throttle controls	30
25	Gear Box	31
26	Technical verification	31
27	Dangerous machines	33
28	Sound level control	33
	Diagrams	37

## **1. GENERAL**

The following appendices apply to the FIM Flat Track world championship in addition to the rules laid down in the FIM sporting code and the FIM Track Racing appendices.

In the following appendices, "He" is used in a non-sexist way and must be understood as "she/he".

### The Flat Track bureau:

The Flat Track bureau is competent to study and approve amendments to the Flat Track regulations proposed by the CCP or by other parties involved such as riders, teams, manufacturers, etc. referred to hereafter as the FIM FT bureau

The FIM FT bureau group shall consist of:

- The FIM CCP director
- The FIM sports director
- The FIM CCP coordinator

### **1.1 Titles**

The FIM recognises the FIM Flat Track world championship in the field of Track Racing. This championship is run under the authority and jurisdiction of the FIM and shall be organised in accordance with all FIM rules.

### **1.2 Definitions**

A Flat Track meeting consists of all official activities related to racing, starting with the first administration controls and technical verifications until the settlement of all possible protests which are to be dealt with by the jury or the referee, if the jury does not exist.

The actual racing consists of a series of several heats, between 4 or more riders, referred to hereafter as rider(s), run on a Flat Track or a TT track – please refer to FIM STRC for flat track requirements.

These meetings may be run between riders competing individually. Each heat will be limited to one class of motorcycles of the same group.

The FIM world championship, recognised by the FIM, referred to hereafter as the FIM Flat Track World championship may be staged as a final series.

In accordance with prevailing circumstances, the FIM FT bureau at its sole discretion may cancel, alter, change or amend ANY aspect of the system and/or diagrams (i.e. the selection of wild card riders, permanent riders, nominated riders, etc.) in respect of any FIM championship at any time.

### **1.3 Supplementary regulations**

Supplementary regulations, referred to hereafter as SR, must be issued by the FMNR in accordance with the FIM sporting code, the Track Racing appendices or these regulations.

For all meetings counting towards the FIM Flat Track world championship, the SR must be published in english and must be approved by the FMNR and the FIM, and subsequently ratified by the international jury. One copy must be sent to the FIM administration at least two months before the date of the meeting for approval by the FIM, by electronic mail.

After approval, and not later than 1 month before the date of the meeting, the FIM must send copies of the approved SR to all persons concerned or connected with the meeting (international jury members, FIM officials, FMNs, riders, teams etc).

The SR must in no case modify the FIM sporting code and must be drawn up in conformity with the standard model established by the FIM FT bureau.

#### *Amendments to the supplementary regulations*

No amendment may be made to the SR after their approval by the FIM administration or the FMNR. However, in exceptional circumstances, the international jury or, if the meeting has not started, the FMNR after approval of the FIM, may authorise, an amendment to the SR, which must be brought to the attention of all persons concerned.

### **1.4 Dates of the meetings**

The meeting diagrams and the dates on which the FIM Flat Track world championship meetings are to be held will be prescribed, according to art. 20.1.1 of the FIM sporting code, by the FIM FT bureau. Each meeting will be allocated to an FMN. To provide for postponements which may be necessary (due to bad

weather conditions for example); the FMNR must declare a re-staging date, which should always be the day following the original date of the meeting, and notify accordingly in the SR.

If the meeting cannot take place on either of the specified dates, the FIM FT bureau will agree an appropriate rerun date and venue.

### **1.5 Responsibility for organisation**

The organiser of the meeting, whether an FMNR, an individual, a club, a corporate body or a member of such a club or body, is responsible for the overall staging and organisation of the meeting for which a permit or other authorisation has been granted by the FMNR, and for provision of all equipment required for the efficient running of the meeting.

In accepting these responsibilities, the organiser undertakes to ensure the loyal observance of all rules and provisions of the FIM sporting code, its appendices and regulations.

## **2. OFFICIALS**

### *Appointment of officials*

For FIM championships (which comprise an international jury), the jury president and the referee are appointed by the FIM. The other officials are appointed by the FMNR.

### *Incompatibilities of officials*

An official may not be a competitor, team manager, team member, mechanic, manufacturer's representative or sponsor participating in the meeting.

An FMN delegate may act as a team manager if he has, in accordance with art. 2.4.14, been entered into the meeting also as a team manager.

### *Officials who hold a FIM licence*

When on duty at FIM World championship, any of the following officials must be a holder of the appropriate FIM international official's licence which is valid for the current year:

- Jury president
- Referee
- FMN and FMNR delegate
- Clerk of the course
- Technical director
- Technical steward
- Timekeeper\*
- Environmental steward
- **National** Team manager

\* In respect of the timekeeper position, an organiser may appoint a non FIM licenced timekeeper in which case the recorded times will not be considered official for FIM purposes.

### *Terms of reference of officials*

#### *International jury president*

The president of the international jury (jury president) ensures that the decisions of the international jury conform to the provisions of the FIM sporting code, to the FIM rules and the SR of the meeting.

The jury president shall, if necessary, convene any extraordinary meetings.

The jury president has the right to invite any guests to the international jury meetings, when appropriate for the meeting.

He is responsible for the communication with the FMN delegates.

In case of absence of the jury president, the position will be replaced by the referee appointed by the FIM.

A meeting of the international jury shall be called before the first official practice session and during this meeting the international jury shall approve, control or reject the following matters:

- Approve the SR and any amendments.
- Report of the clerk of the course stipulating that all riders and participants engaged are in possession of their respective licences as well as all officials with any responsibility for the running of the meeting.

- Report from the clerk of the course showing all steps to be taken to ensure the orderly running of the meeting.
- Report and control of the safety standards of the meeting.
- Approve, control or reject any amendments of requests for extra safety measures as mentioned in the track inspection report.
- Control, of the official permission from the local authorities to run the meeting and of the third-party liability insurance policy of the organiser.

At the end of the official practice, during a session of the international jury, the president will hear the reports of all the appropriate officials.

At the end of the meeting, during the last session of the international jury, the president, together with the referee, must sign the official classification of the meeting. He must also sign, with the secretary to the international jury, all minutes of the meetings.

The jury minutes must include details of any outstanding fuel test results where laboratory testing is required. In the event of any anomaly being officially confirmed by the FIM, the jury president will reconvene the jury and impose appropriate penalties as required by these regulations.

**He shall send a short report of the meeting straight after the last jury meeting (number of spectators, accidents, ....) and the following documents to the FIM administration within 72 hours of the finish of the meeting:**

- The jury president's report and the minutes of the international jury meetings (using the official form),
- Details of any protests submitted together with the security deposits collected,
- Copy of the official spreadsheet duly filled in.

### *Referee*

When on duty, during practice and racing, the referee exercises supreme control over the meeting and he is responsible for ensuring that all regulations are observed. He may consult the jury president if he considers his advice necessary.

The referee has no responsibility for the organisation of the meeting and he has no executive duties other than those defined in these regulations.

He is entitled to refuse access to his box to any person other than the clerk of the course, and when on duty in his box, no person shall speak to him without permission.

The referee's report must include details of any penalties imposed, delays which may have occurred, protests received and any other incidents which it is considered should be brought to notice.

He must prohibit any rider/team from taking part or any machine from being used in practice or in racing if, in his opinion, other rider/team or the public would be endangered.

He must ensure that all his decisions which may affect or vary from the published programme, such as the rerunning of a heat and the disqualification of a rider are communicated immediately to the clerk of the course for action.

If a degradation of the track or any other such situation occurs during practice or racing which could cause the postponement, stopping or abandonment of the meeting, the referee should request the jury president to call an immediate international jury meeting for an appropriate decision which is to be communicated immediately to the clerk of the course for action.

However, the clerk of the course and the riders must be consulted before any decision concerning weather conditions, surface of the track, visibility of riders or for any other reason which could lead to a dangerous situation for riders or spectators.

The decisions of the international jury are to be announced by the speaker to the public.

The referee may inflict a penalty on any person who fails to comply with any regulation or instruction given, or is guilty of misconduct or unfair behaviour, or who shows by word or action dissent from any decision given by the referee or other authorised official.

The penalty may take the form of a warning, a fine or a disqualification of a rider from one or more heats, removal from the meeting and/or a warning or a report to the FMN of the rider for action as that body may consider fit.

The referee shall give the reason for a penalty if the person concerned makes a request for an explanation. Having provided the explanation, the referee may not discuss it in private or in public.

When on duty, during practice and racing, the referee shall deal immediately with any protest, submitted

to him through the clerk of the course in accordance with the FIM disciplinary and arbitration code, these present rules, and the SR.

The referee, in agreement with the international jury, shall satisfy him/ herself as to the correct handling of technical controls of the riders' machines and safety equipment and determine, in conformity with the FIM medical code and the anti-doping code, what controls of the riders' physical conditions are to be made, i.e. medical and doping tests.

The referee must judge in which order the riders cross the finish line and this decision, once announced, is final and may not be the object of a protest.

At the end of the meeting, during the last jury meeting, the referee together with the jury president must sign the official classification of the meeting.

The maximum age limit for referees officiating at FIM championships is 60 years.

The referee appointed by the FIM to officiate at a FIM championship cannot act as manager of a national team or individual rider in any Track Racing championship of that year.

#### *FMNR delegate*

The FMNR delegate can attend international jury meetings with voting rights.

#### *Clerk of the course*

The clerk of the course is responsible for the conduct and efficient running of the meeting.

He is not a voting member of the jury but is considered as -in case of no FMNR delegate- is nominated as representative of his FMN.

The clerk of the course cannot be a team manager in a competition while appointed as clerk of the course with voting rights.

It is strongly recommended that the clerk of the course speak one of the two official FIM languages. If not, a competent translator must always be available.

They must ensure that the track receives timely and adequate preparation before practice and before racing and that all facilities are provided to maintain the track in a satisfactory condition during practice and during racing.

They must exercise authority over all officials of the meeting (except for the international jury members) and is responsible for ensuring that they are present and ready to carry out their duties properly.

They must verify the identity of the riders; the correct numbering of the motorcycles, and that there is nothing to prevent a rider from participating in the meeting, e.g. suspension, disqualification or any other ban on riding.

They must ensure that all riders taking part in the meeting have signed on and give the signing on list to the jury president.

They must carry out as soon as possible all instructions received orally (directly or by telephone) or in writing from the referee.

They must provide any information regarding the organisation and control of the meeting which he considers relevant for the international jury or the referee to know or which may be requested by the international jury or the referee.

They must prevent any person from communicating directly with the referee, when he is on duty in his box, (including communicating by telephone), without the referee's permission.

They must ensure that protests are in order and accompanied by the appropriate security deposit before passing them to the referee.

They must notify the international jury and the referee of all decisions to be taken or already taken, and of any protest addressed to him.

They ensure that the FIM rules are respected. He may propose penalties to the referee or the international jury.

They must order the removal from the circuit, track or venue and its vicinity of any person refusing to obey the orders of an official in charge.

They must ensure that no machine or engine is removed from the pits without the authorisation of the referee until 30 minutes after the last race.

They must ensure that the speaker has taken notice of his duties as mentioned later in this article.

They must collate the reports of the timekeepers and other executive officials and all other information necessary to present his report to the international jury and have the provisional results of the meeting approved.

### *FIM technical director*

- The FIM technical director is appointed by the director of FIM international technical commission in consultation with the director of FIM Track Racing commission.
- The FIM technical director is not responsible for the technical verifications but will ensure that they are carried out in accordance with the FIM technical code.
- The FIM technical director works in cooperation with the FIM race director/jury president and FIM delegate/clerk of the course.
- The authority and duties of the FIM technical director include but are not limited (please, also refer to FIM technical code):
  - a) The FIM technical director will report any concerns or deficiencies relating to the technical verifications to the FIM jury president and present proposals to resolve such concerns.
  - b) The FIM technical director is the final arbiter in relation to technical issues at the event.
  - c) The FIM technical director will examine with the chief technical steward the motorcycle(s) and the protective equipment of any rider(s) involved in serious or fatal accidents and presents a written report to FIM jury president.
  - d) The FIM technical director will attend all jury meetings but without voting rights.

### *Technical steward*

The technical steward must verify the machines, clothing and helmets in accordance with the FIM rules, appendix 01 (Track Racing technical rules) and the SR. He must present his report to the international jury prior to and after racing.

### *Chief medical officer (CMO)*

The chief medical officer must fulfil the duties required in the FIM medical code.

### *Environmental steward*

The environmental steward shall be responsible for all environmental aspects. He must fulfil the duties required in the FIM environmental code.

### *Timekeeper*

The timekeeper must be qualified to use a timekeeping system.

He must record the times taken in each heat by the winner and the time taken by any other rider, if so required by the referee.

The times, but no other information, may be conveyed to the public.

The records of times must be certified by the timekeeper, retained for scrutiny and not destroyed without the authorisation of the clerk of the course.

He must advise the FMNR of all track records established during a meeting.

### *Speaker*

The speaker must give members of the public such information as they may reasonably require understanding the sport they are watching and to enjoy it.

He must communicate all information as required by the referee, but may not comment on, give an opinion on or amplify such information or any decision made by the referee.

He must be strictly impartial in what he says and refrain from any statement which might incite members of the public to demonstrate against or denigrate an official, rider or to encourage any section of the public to be an annoyance or nuisance to another section.

He must not convey to the public, information which is contrary to the FIM sporting code or the SR, or which is untrue, or information on any protest or appeal, which may be lodged.

The results must also be communicated in english.

### *Starting marshal*

The starting marshal is responsible for:

- Ensuring that before the beginning of practice and racing, signaling flags, disqualification discs, spare starting gate tapes and elastics, track marking equipment, rakes and fire extinguishers are readily

available and in order.

- The layout and marking of the starting area comply with regulations, and that all starting positions are raked, graded or swept to give an even surface immediately before each heat;
- **The riders are controlled when they are preparing to start in a heat and that he remains in front at the start/finish line with a red flag until he is satisfied all riders are in their correct positions and ready to start. When the Start Marshall is satisfied they will signal to the referee who will wait the start marshal must commence to walk clear of the riders, then illuminate the green light to indicate to the riders the race is about to start.**
- On the showing of the referee's signal, the start marshal must commence to walk clear of the riders.
- Signals for the stopping of a heat (or the disqualification of a rider) given by the referee are repeated by;
- Flag signals are to be made, as agreed and directed by the referee, should the starting gate or signal lamps fail or not operate in a proper and acceptable manner.

#### *Flag marshals*

Please refer to the STRC – Flat Track / TT section.

#### *Pits' marshal*

The pits marshal and his assistants must be permanently present in the pits area during the FIM meeting.

The pits' marshal is responsible for ensuring that:

- only the riders and their teams and other persons with appropriate passes (police, fire and medical staff in uniform and doctors, do not need passes for identification) are permitted in the pits;
- all necessary equipment, including fire extinguishers and emergency tools (see appendix 079, "STRC") are in order;
- machines are positioned in the pits in order according to riding numbers or by nationality to facilitate quick identification;
- riders, passengers and machines carry the correct riding numbers according to the programme;
- riders concerned are marshalled in readiness for the heat in which they are competing immediately after the previous heat has started;
- before authorising riders and machines to leave the pits for practice or racing, the track is clear of all obstructions;
- the gate between track and pits is opened only when necessary for access for riders, machines and pusher-off, and that, during racing, the gate is properly closed and all persons in the pits are kept at a safe distance from it;
- instructions from the referee or clerk of the course are clearly understood and carried out.
- nobody smokes in the pits area.
- during the race and the practice session, except for the riders, only persons who have reached their age of majority/adulthood can enter the pits with valid accreditations.
- no rider, mechanic, manager or delegate goes on the track when track maintenance is in progress.
- a race card, placed in the pits area, is filled in and updated according the points scored during the meeting.

#### *FMN delegate*

Each FMN which has a rider participating in a FIM championship is entitled to be represented by a national delegate, holder of a sporting steward's licence.

All such nominations must be submitted in writing to the FMNR. The FMNs must inform the FMNR of the name of their delegate not less than 15 days prior to the meeting.

This national delegate represents his/her FMN and the riders entered by that FMN.

He is entitled to :

- attend the open meetings of the international jury, as observer,
- receive documents, including the international jury minutes, during the entire meeting,
- submit his queries to the jury president so that the international jury is aware of all circumstances,
- receive passes to be present at important places during the meeting.

If necessary, the jury president will arrange a meeting with all FMN delegates to explain the work of the international jury and to receive the remarks of the FMN delegates.

#### *INTERNATIONAL JURY*

The members of the international jury with voting rights are: the jury president, the referee and the FMNR delegate/clerk of the course.

In the case of a tie, the jury president has the casting vote.

The following persons are entitled to attend the meetings of the international jury but without the right to vote: the members of the board of directors, the directors of the permanent commissions and panels, the FIM chief executive officer, the FIM sports director and the administrative staff of the sporting commission concerned, the environmental steward, the chief medical officer, the technical director, technical steward, the FMN delegate(s), the team managers and any guests in possession of an FIM licence invited by the jury president.

#### *Nominations*

For FIM championships with or without a FIM promoter, the nomination of the jury president and the referee will be decided by the FIM/CCP.

Terms of reference of the international jury: please refer to art. 50.1 of the FIM sporting code.

Procedure at international jury meetings: decisions of the international jury are based on a simple majority. In the case of a tie, the president will exercise a casting vote.

Publication of the international jury decisions: All decisions of the international jury necessary for the running of the meeting as well as the results must be published as soon as is reasonably possible. The decisions must be published at least in the english language.

#### *Minutes of the international jury meetings*

The minutes for all FIM championships must be written in the english language. They are to be prepared by the secretary to the international jury and must be signed by him/her and the jury president. A copy of these minutes must be sent to the FIM administration within 72 hours after the meeting in respect of meetings counting towards a FIM championship.

The minutes must state in detail any penalty imposed; the decisions taken concerning any protests received (copies of which must be attached; any possible irregularities observed, as well as the opinion of the international jury regarding the success of the organisation and any possible remarks they consider to be worthy of special mention.

#### *International jury meeting room*

A special jury room fitted with a large table and enough chairs must be provided for the jury to conduct their meetings. A printer must be available in the room and preferably a photocopier. A secure and reliable wi-fi internet connection must also be provided. The room must be prepared, available and free always prior, during and after the meetings. Coffee, soft drinks, snacks etc. must be available at each jury meeting. If the room is always not manned the jury president, the clerk of the course and the secretary must be given personal keys for entering.

### **3. RIDERS**

#### **3.1 Medical certificate and examination**

Every rider taking part in Track Racing meetings must be medically fit.

A special medical examination may be carried out at any time during a meeting by an official doctor or by another doctor nominated by the chief medical officer (CMO) at the request of the jury president, referee or the FIM medical representative.

Any rider who has suffered an injury requiring hospital treatment and who has not since raced in any official meeting must provide a medical certificate in english or french confirming fitness to take part in the meeting.

In addition, the international jury will require the rider to submit to a full medical examination by the chief medical officer or an approved deputy before being allowed to take part in the meeting or practice. Furthermore, as proof of fitness it is compulsory for the said rider to take part in the scheduled practice session for the meeting unless excused by express permission of the FIM FT bureau.

Please refer to the FIM medical code.

### 3.2 Age of riders

Licences for riders are issued for **FIM Flat Track world championship, as well as for Flat Track international meetings**, only when the minimum age has been attained as below:

Minimum	Maximum
16 years	-

The minimum age for each category of meetings starts on the competitors' minimum age birthday. For applicants aged over 50 years, please refer to the FIM medical code.

### 3.3 Licences

In conformity with the FIM sporting code, the riders must be holders of an appropriate and valid FIM World championship Track Racing licence to be allowed to take part in a FIM Flat Track world championship:

- Annual FIM Speedway Grand Prix world championship licence;
- **Annual Flat Track world championship licence;**
- Annual / one event FIM Track Racing world championship licence;
- Annual / one event Flat Track world championship licence;

The FIM team sporting licence must be implemented according to the sporting code art. 70.2.

Annual **permanent riders'** licences will not be required to be shown as the FIM will provide to appropriate officials a list of licensed riders in advance of the competition dates.

### 3.4 Entries

On agreeing to enter the final series, a rider will participate into all the FIM Flat Track world championship final series meetings, he may be called up to do unless prevented from doing so by injury or other "force majeure".

In the case of injury or illness a suitably qualified medical body must certify injury or illness in writing to that effect.

A rider's FMN is responsible for the completion of this entry form and submitting it to the FIM/CCP administration, furthermore, the rider commits himself by his signature to be fully aware of all the FIM rules; to accept them all and to compete in the FIM Flat Track world championship meeting for which he has been nominated.

A nominated substitute rider, who without a reason accepted by the FIM FT bureau refuses to take part in a meeting, may be removed from the nominated substitute rider list for the rest of the season.

If no "nominated substitute" are available, the FIM FT bureau may select one or more substitute riders.

#### *Cancellation of an entry*

A penalty of suspension entails the cancellation of all entries made by the sanctioned rider for any meeting to be held during the period of suspension.

### 3.5 Fines

Every breach of the rule shall be penalised with a fine or penalised with another sanction provided for in the FIM disciplinary and arbitration code. The sanction must be proportional to the offence, and to the circumstances (attenuating or aggravating if applicable) and taking account of any possible advantage gained by the rider. Riders breaking the rules shall be sanctioned by the international jury as follows:

Any inappropriate conduct	AMOUNT
with words or signs with violence	<b>1000€</b> 2.000 € and up to disqualification from the meeting
Arriving after the start of heat 1	600 € Disqualification from the meeting
Absence without having advised the <b>FIM and/or</b> organiser in <b>writing</b> or absence after having advised the <b>FIM and/or</b> organiser in <b>writing</b> but for a reason not accepted by the international jury	2000 €
ABSENCE OR LATE ARRIVAL AT THE: Machine Examination Signing on Practice Riders' briefing Parade Prize-giving ceremony Press conference	300 € 300 € 300 € 300 € 300 € 300 € 300 €
<b>Championship logo not stuck on the front plate when required during parade, racing, draws, in the pits, interviews, prize giving ceremony, press conference</b>	600 €
Not using an environmental mat in the pits, <b>parc fermé</b>	70 € per mat

All other offences to the rules will be penalised according to the FIM disciplinary and arbitration code. Riders are responsible for their mechanics.

### 3.6 Starting numbers

The starting numbers will be balloted. A balloted position is open to any nomination from the FMN concerned, up until the rider signs on or reports to the clerk of the course at the meeting.

Places made vacant by withdrawals will be filled by FIM FT bureau decision and any FMN not honouring its engagements may be penalised after an investigation of the circumstances by the CCP.

### 3.7 Riding numbers

Each rider accepted for the FIM Flat Track world championship will be allocated a series number between 1 and 30, which will be valid for the FIM Flat Track world championship series of that year.

Additionally, the permanent riders may apply to use their own personal racing numbers on their race jacket / race suits and bikes. They may choose any riding number with a maximum of 3 digits if it has not previously been allocated to another rider, the number cannot start with a 0. To request a specific personal racing number the rider must send an application to FIM within a set deadline. Should more than one rider request the same number, preference will be given to either the rider who has a clear history of adopting that number, or if this is not the case for either rider, then the higher ranked rider will be allocated this number. Other riders will then need to select an alternative number. Riders who have not requested a specific personal riding number within the deadline will be required to use their allocated Flat Track number.

Wild card rider will be allocated numbers 33-34-35-36-37 if he has not requested a special number within the deadline (3 weeks before the event).

### 3.8 Permanent riders

Permanent places for the final series meetings will be confirmed by the FIM FT bureau.

### **3.9 Wild card riders**

For a separate final meeting, the FMNR is permitted to nominate one wild card rider approved by the FIM FT bureau. The proposal must be made in writing to the FIM not later than 1 month prior to the meeting.

**The FIM FT bureau will also nominate 1 wild card per event.**

### **3.10 Nominated substitute rider**

A rider appearing on the approved list of nominated substitute riders for a Final series. If an originally permanently nominated rider is unable to participate and the time allows, they will be replaced by the next rider from the list of nominated substitute riders of that discipline.

A nominated substitute rider must take part in any meeting into which they are promoted on the notification/instruction of the FT bureau.

### **3.11 Signing on**

All riders must sign-on during the period stipulated in the SR. By signing-on, the rider enters the venue and accepts to be under the jurisdiction of all FIM rules and regulations applicable to the meeting. The signing-on time shall expire 30 minutes before the first international jury meeting. No rider or official can leave the meeting without the authorisation of the referee until the time limit for protests has elapsed. When a rider has signed on they are deemed to have entered the meeting and is not permitted to take part in any other motorcycle meeting until completion of the event.

### **3.12 Health and safety**

In the best interests of health and safety, in the event any incident whatsoever occurring within the competition arena, under no circumstances is any member of a competitor's support team (mechanic, sponsor etc.) allowed to enter the arena without specific authority to do so having been given by the clerk of course or their appointed deputy. In circumstances where authority is given, activity should be limited to the safe recovery of a competitor's racing machine. There should be no interference with the activities of the CMO or medical support team under any circumstances unless in unusual circumstances assistance is specifically invited by the CMO.

## **4. TRACKS**

### **4.1 Standards**

The track must comply with Appendix 079 "FIM Standards for Track Racing Circuits" (STRC).

Tracks used for FIM Flat Track world championship must be homologated by the FIM and have a valid FIM track licence.

## **5. MOTORCYCLES**

Please refer to technical rules of this rulebook.

### **5.1 Artificial heating of tyres**

The referee shall immediately disqualify a rider whose motorcycle's rear tyre has been artificially warmed prior to the start of a heat. This includes the spinning of the rear wheel whilst in contact with the track or any other object. This does not apply to practice starts.

### **5.2 Number of motorcycles**

Each rider will be allowed a maximum of 2 motorcycles in the pits during racing.

These two motorcycles must be placed in the riders' allocated pits' area immediately after the machine examination has taken place.

Motorcycles taken outside the controlled pits' enclosure or track area shall be re-presented for inspection before they can again be placed in the allocated pits' area.

If needed, any extra motorcycle can be parked in the specially provided "standby" area, near to the pits.

## 6. PRACTICE

Every organiser must plan a practice session open to all entered riders, according to the provisions contained in this article.

Information about the date and time for practicing must be clearly stated in the SR.

Weather conditions and accidents may dictate alterations to this procedure, which may only be decided by the international jury.

If the weather and the track conditions are good, the international jury may permit an additional practice session for riders who participate in additional heats.

No machine or mechanic shall be permitted on the infield during any practice run.

During the 2 minutes time allowance, the mechanics must only work on his rider's bike within the controlled area. Mechanics may only leave the controlled area to assist his rider in an emergency.

For safety reasons it is forbidden to make practice starts on the corners or on the starting straight.

Furthermore, mechanics and support crew must remain in vicinity of the pit and pit gate area during practice unless assisting with the recovery of a damaged or failed machine.

A competitor is considered having practiced having completed 2 laps during the official practice session.

The practice must be arranged not earlier than one day before racing and, if planned on the same day as racing, the practice must be scheduled to start a minimum of 3 hours before the 1<sup>st</sup> heat.

Each rider must make himself ready in the lining-up zone, within the time limit of his group. On the order of the clerk of the course he will be allowed to enter the track. Riders must practice according to their riding numbers. However, if the rider is not ready, he will miss that run.

PRACTICE COMPULSORY	SESSIONS	START PRACTICE	MAX. RIDERS ON TRACK
YES	2 x 5min.	NO	10

## 7. RACES

**The number of the laps will be decided on the 1<sup>st</sup> international jury meeting before the event.**

### 7.1 Direction of racing

All heats are run in an anti-clockwise direction.

### 7.2 Punctuality in starting

All heats must start at the time announced and riders must hold themselves ready for the start when called upon to do so by the appointed official.

The referee must indicate the start of a 2 minutes period by means of a warning horn or bell audible in the pits area together with the flashing amber lights.

Except when the referee considers that there are valid reasons for delaying the start of an ensuing heat, the interval between the finish of one heat and the start of the next shall not exceed 4 minutes including the 2 minutes period as mentioned above. Should any of the riders not be ready to start, they shall be disqualified from the heat.

### 7.3 Delaying the start

A rider who fails to ride directly and without delay from the pits to the starting line, delays the start in any other manner may be disqualified from the heat at the sole discretion of the referee.

### 7.4 Starts

On the order of the pits' marshal (or after a signal in the pits) the required riders must leave the pits together and proceed under power immediately in an anti-clockwise direction to the starting area where they must stop under the control of the starting marshal.

Engines must be kept running, machines parallel with the inner edge of the track and front wheels not more than 10 cm from each row starting line.

**The referee, when satisfied that the riders are correctly positioned, must switch on the green light indicating that the start is imminent. After a pause long enough for the riders to fix their attention on the green light and are standing still, the referee must switch off the green light that permitted the start.**

#### 7.4.1 False starts

**Any competitor who allows their motorcycle to move forward after the referee has switched on the green light must be handicapped by 15 metres from the back line of the grid if there is a re-start. He must occupy the outside position on the track.**

#### 7.5 Race stoppage

At the sole discretion of the referee, any competitor who causes a race to be stopped will either be disqualified from the re-run or if reinstated will be handicapped by 15 meters (measured rearwards from the back line of the grid).

N.B. Handicapped riders will always occupy the outside position.

In the case of a race stoppage:

6 laps race: 5 laps completed by all riders still under power – result to stand based on the positions at the time of the stoppage.

8 laps race: 6 laps completed by all riders still under power – result to stand based on the positions at the time of the stoppage.

10/12 laps race: 8 laps completed by all riders still under power – result to stand based on the positions at the time of the stoppage.

#### 7.6 Re-staging or abandonment of a meeting

To be confirmed depending on the format.

#### 7.7 Faulty starting gate

If, because of faulty operation of the starting gate/lights, or for any other reason, the referee considers a start to have been incorrect, he must immediately stop the heat and order a restart with all riders competing.

#### 7.8 Starting assistance

After the green light has been switched on (or other starting warning given), or the start machine being released, an outside assistance may be given to any rider.

If, at that time, a rider's machine is not moving under its own power, the rider concerned will be handicapped by 15 meters (measured rearwards from the start line).

N.B. Handicapped riders will always occupy the outside lane) and will go to the back of the grid or be placed 15 m from the back of the grid if a re-start.

#### 7.9 Leaving the track

A rider whose machine crosses the inner edge of the track marking with 2 wheels must be disqualified unless, in the opinion of the referee, the action was taken in the interest of safety for other riders or the rider involved was forced off-course by another rider.

This rule also applies to the crossing of the marking of the outer edge of a track.

#### 7.10 Foul or dangerous riding

The referee shall immediately disqualify any rider (or riders) whom he considers indulges in foul, unfair or dangerous riding.

A rider, who, having started in a heat does not make an honest attempt to ride to the best of their ability, as judged by the referee, shall be guilty of an offence, which may entail disqualification from the heat or a penalty.

There shall be no protest or appeal against a referee's decision to declare a heat completed or as to his statement of foul, unfair or dangerous riding.

If, in the opinion of the referee, such conduct produces an advantage to the rider (or team) involved or affects the chances of one or more riders, the referee may stop the heat and order a re-run.

If any rider is unable to cross the finish line as a result of foul, unfair or dangerous riding on the part of another rider who, in consequence, has been disqualified, the disadvantaged rider shall be deemed to have finished the heat in the placing held immediately before the foul, unfair or dangerous riding and allowing for any advancement in placing following the disqualification of the guilty rider.

A similar system shall apply for a rider who, in the opinion of the referee, has deliberately laid down his machine or has left the course in the interest of safety.

### **7.11 Time limit**

No protest or appeal is permitted against this rule.

A rider must be considered as having retired from a heat if he has not started their last lap before the winner has crossed the finish line.

### **7.12 Finish of a heat**

The finish of a heat shall occur in the case of any of the following circumstances.

- a) when the front part of the front wheel of the motorcycle (whilst attached to the machine) passes over the finishing line after completing the appropriate number of laps provided the competitor is in contact with his motorcycle.
- b) when the referee has awarded the heat as provided for in these regulations.
- c) If the referee has caused to stop a heat after the leading rider has passed the start/finish line to commence the last lap, the disqualified rider will be awarded no points and any competitors behind the disqualified riders being advanced one place.
- d) Where racing incidents etc. have reduced the riders available to take part in the re run of any heat to a single competitor, the referee may award the appropriate number of points to the remaining competitor without the need for a further rerun.

### **7.13 False finish**

When a heat has been indicated as finished by display of the black- and-white chequered flag before the required number of laps has been completed by the leading rider, the referee may declare the heat void and order a rerun except when the race has been awarded as allowed for.

If the black-and-white chequered flag has not been shown after the completion of the required number of laps, the flag shall be considered to have been shown.

### **7.14 Rerun heat**

If an accident on the track occurs and, in the opinion of the referee, it is dangerous for the heat to continue, he must stop the heat. Only the referee is empowered to order a heat to be stopped.

Any rider who, for any reason, is deemed to have been the primary cause of the heat being stopped shall be disqualified.

The referee may permit any rider who has fallen because of having been fouled or because they have deliberately laid down their motorcycle or left the course in the interest of safety to take part in the rerun. In such cases any outside assistance may be ignored.

Any rider eligible to take part in a rerun may change their motorcycle for the rerun.

When taking part in a rerun, riders must start from their original starting positions –except for the handicapped rider(s).

Any rider who has failed to start in, has retired from (which includes not proceeding under power when the heat was stopped) or has been disqualified from a heat which has been ordered to be rerun, shall be ineligible to take part in the rerun, except in circumstances where they have retired after being fouled or have stopped in the interest of safety as described above.

## **8. RESULTS**

### **8.1 Calculation of results**

Results are determined by points related to finishing order or in the last chance and the final (without points) are determined only related to finishing order and chronological order in case of riders not finishing the heat.

The winner of the heat is the rider who has completed the required number of laps in the shortest time. The riders following are placed according to the order of crossing the finish line.

Only the referee is entitled to determine the points or placing for each rider in each heat. His decision, once announced, is final and may not be the object of protest. Once the referee has declared a heat over and he has announced the finishing order and respective points, in no case shall that heat be re-run. (The only exceptions are being explained in false finish or rerun heat articles)

In very special circumstances however involving situations that are beyond the control of the Referee and have influenced the heat result the referee can take a decision to order a re-run of the heat concerned or amend the result of the heat before the start of the next heat or within 5 minutes in the case of the last heat of the meeting.



After heat 16:

- Riders 1<sup>st</sup> to 10<sup>th</sup> will be qualified for the final heat.
- Riders 11<sup>th</sup> – 20<sup>th</sup> will be qualified for the last chance heat.

Top 2 of the last chance heat will qualify for the final.

### World championship points system

1 <sup>st</sup>	25pts	1 <sup>st</sup> place in the final
2 <sup>nd</sup>	22pts	2 <sup>nd</sup> place in the final
3 <sup>rd</sup>	20pts	3 <sup>rd</sup> place in the final
4 <sup>th</sup>	18pts	4 <sup>th</sup> place in the final
5 <sup>th</sup>	16pts	5 <sup>th</sup> place in the final
6 <sup>th</sup>	15pts	6 <sup>th</sup> place in the final
7 <sup>th</sup>	14pts	7 <sup>th</sup> place in the final
8 <sup>th</sup>	13pts	8 <sup>th</sup> place in the final
9 <sup>th</sup>	12pts	9 <sup>th</sup> place in the final
10 <sup>th</sup>	11pts	10 <sup>th</sup> place in the final
11 <sup>th</sup>	10pts	11 <sup>th</sup> place in the final
12 <sup>th</sup>	9pts	12 <sup>th</sup> place in the final

13 <sup>th</sup>	8pts	3 <sup>rd</sup> place in the last chance
14 <sup>th</sup>	7pts	4 <sup>th</sup> place in the last chance
15 <sup>th</sup>	6pts	5 <sup>th</sup> place in the last chance
16 <sup>th</sup>	5pts	6 <sup>th</sup> place in the last chance
17 <sup>th</sup>	4pts	7 <sup>th</sup> place in the last chance
18 <sup>th</sup>	3pts	8 <sup>th</sup> place in the last chance
19 <sup>th</sup>	2pts	9 <sup>th</sup> place in the last chance
20 <sup>th</sup>	1pt	10 <sup>th</sup> place in the last chance
21 <sup>st</sup>	0pt	21 <sup>st</sup> place after last qualif. heat
22 <sup>nd</sup>	0pt	22 <sup>nd</sup> place after last qualif. heat
23 <sup>rd</sup>	0pt	23 <sup>rd</sup> place after last qualif. heat
24 <sup>th</sup>	0pt	24 <sup>th</sup> place after last qualif. heat
25 <sup>th</sup>	0pt	25 <sup>th</sup> place after last qualif. heat

The FIM Flat Track world champion will be the rider having collected the most world championship points at the end of the final meeting series.

#### 9.2 Ties

*After the completion of the qualifying heats*

When establishing the order between the riders in the list of intermediate classification at the conclusion of qualifying heats, any ties will be solved as follows:

Precedence will be given to the riders (tied on race points) having the better placings (a “0” for last placing is better than being disqualified for whatever reason).

If the tie persists and involves only 2 riders, precedence will be given to the better placed rider in the heat or heats where the 2 riders met.

**If the tie persists the order will be determined by ballot.**

*The intermediate final series classification*

In case of riders tied on Flat Track points in the intermediate classification, precedence will be given to the rider having the greatest amount of Flat Track 1<sup>st</sup> place results, followed by 2<sup>nd</sup>, 3<sup>rd</sup>, 4<sup>th</sup> and so on in the current season. If the tie still persists precedence will be given to the rider with the highest final classification at the last round of the current season.

#### The final overall classification

In case of riders involved in a tie on the final overall classification, at the end of the Flat Track series, the following will apply:

- 1 Run-off for 1<sup>st</sup> place.
- 2 For all other placings: Precedence will be given to the rider having the greatest amount of 1st place results, followed by 2<sup>nd</sup>, 3<sup>rd</sup>, 4<sup>th</sup> and so on in the current season. If the tie still persists precedence will be given to the rider with the highest final classification at the last round of the current Flat Track season.

#### 9.3 Run-off heats

In all run-off heats concerning the ties, the starting positions at the gate shall be balloted in presence of the jury president.  
starting area

If only two riders take part in the run-off, the starting area must be divided into two equal parts (outer and inner start position).

If three riders take part in the run-off, the starting area must be divided into three equal parts.

#### **9.4 Communication of results**

Compulsory: The organiser will supply a scoreboard and must supply a person responsible for inputting the results of each heat on the scoreboard located in the pits.

Immediately after the meeting, the FMNR must send by e-mail to the FIM the complete results of all participants who competed in their meeting. The original of all documents sent by e-mail must also be signed by the jury president and the referee and sent to the FIM by mail.

The results must contain at least the following information:

- FIM, FMNR, organiser/moto club, championship Logos
- Title, venue, date, FMNR, IMN N° of the meeting
- Position, number, surname(s), first name(s), nationality, FMN of the rider
- Championship points obtained

The jury president is responsible for organising the transmission of the results to the FIM within the hour that follows the approval of the results. This transmission will be made by e-mail to the FIM.

It is compulsory for organisers to make available an appropriate internet connection for use by the jury throughout the period of event.

#### **9.5 Alteration of results**

No alteration to the list of results may be made after the expiry of the time limit, which is set for protests. This does not place any restriction on the right of protest according to the FIM disciplinary and arbitration code.

#### **9.6 Prize-giving ceremony**

In all meetings, after the official programme of heats is terminated, there shall be a prize-giving ceremony. The riders placed first, second and third shall attend the official prize-giving ceremony. The presence of the FMNR or FIM officials at the prize-giving ceremony is not a confirmation of the official results. The riders must present themselves in their racing equipment.

#### **9.7 FIM Awards**

FIM medals and diplomas are awarded to winners in accordance with the FIM sporting code.

### **10. ALCOHOL AND DOPING CONTROLS**

Tests may be carried out at any FIM championships or international meetings to detect alcohol and prohibited substances, according to the provisions laid down in the FIM anti-doping code.

Where alcohol controls are carried out at FIM championships or international meetings, this must be done according to the FIM medical code.

Alcohol controls may be carried out by an alcohol control officer before the start of the practice, or at any time during the meeting.

The sanctions for a positive doping and/or alcohol test will be pronounced according to the rules and proceedings laid down in the FIM anti-doping code, FIM medical code and FIM disciplinary and arbitration code.

### **11. PROTESTS AND PENALTIES**

Protests and appeals are subject to the rules and proceedings provided for in the FIM disciplinary and arbitration code.

Any protest must be lodged immediately after the reason for the protest is known. They must be in writing, stating the article numbers relevant to the protest, and accompanied by the fee stipulated in the SR and submitted to the clerk of the course who in turn will submit them to the referee.

If the protest requires a measurement of the capacity of an engine which proves to be in order, then the protesting party must pay the actual labour costs for dismantling and reassembling the engine, up to a maximum of 660 euros. Any irregularity, error or fraudulent action on the part of the rider (and/or the

machine concerned) that could influence on the result of a heat or the race would be followed by sanctions (cancellation of the points of the heat or the meeting, disqualification, suspension, etc...).

Protests relating to an error, irregularity or fraudulent action on the part of the rider (and/or the machine concerned) that could influence the result of a subsequent heat must be lodged before those concerned leave the pits for that subsequent heat.

If the protest relates to an incident during racing, it must be lodged before the riders leave the pits for their next heat.

Should the reason for the protest occur in the last heat of the meeting, the protest must be lodged within 10 minutes of the finish of that heat. If a protest has been lodged verbally, it must be confirmed in writing not more than 15 minutes later.

*Right of protest and appeal*

No protest or appeal may be made against a decision by a referee or technical steward on a statement of fact.

## 12. SCALE OF EXPENSE REIMBURSEMENT

Travel expenses, as well as long distance and ferry costs, are included in the scale of expense reimbursement. All amounts indicated in the scale of expense reimbursement are shown in euros and are net amounts. All amounts can only be paid to the riders in euros after the last jury meeting at every event or by bank transfer in special circumstances.

1 <sup>st</sup>	250€	11 <sup>th</sup>	95€
2 <sup>nd</sup>	230€	12 <sup>th</sup>	90€
3 <sup>rd</sup>	210€	13 <sup>th</sup>	85€
4 <sup>th</sup>	180€	14 <sup>th</sup>	80€
5 <sup>th</sup>	160€	15 <sup>th</sup>	75€
6 <sup>th</sup>	140€	16 <sup>th</sup>	70€
7 <sup>th</sup>	130€	17 <sup>th</sup>	65€
8 <sup>th</sup>	120€	18 <sup>th</sup>	60€
9 <sup>th</sup>	110€	19 <sup>th</sup>	55€
10 <sup>th</sup>	100€	20 <sup>th</sup>	50€
TOTAL 2355€			

### 12.1 Expense reimbursement in case of cancellation or interruption of a meeting

In the case where a meeting is interrupted, suspended or cancelled for any reason whatsoever so that a proper classification cannot be obtained, and the meeting cannot be restaged on the dates given in the SR, the riders are entitled to receive 50% of the amount shown in the scale of expense reimbursement divided by the number of riders (reserve riders included).

## INTRODUCTION

The term motorcycle covers all vehicles having, in principle, less than four wheels, propelled by an engine and designed essentially for the carriage of one or more persons of which one is the rider of the vehicle. The wheels must normally be in contact with the ground except momentarily or in certain exceptional circumstances.

### 1. EQUIPMENT AND PROTECTIVE CLOTHING DURING PRACTICE AND RACE

The FIM cannot be held liable for any injuries that a rider or passenger may sustain from the use of a specific item of equipment or protective clothing.

#### 1.1 Clothing and protectors

In general, it is recommended to use suit, trousers, long-sleeve shirts and undergarments made of textiles which are not fully constituted of nylon or spandex (e.g. lycra, elastan), in order to avoid degradation in case of abrasion (friction).

It is compulsory that all protective devices are clearly marked with the relative norms and comply with the following standard:

- EN 1621-1, level 2, for shoulders, elbows, hips and knees
- EN 1621-2, level 1 or 2, for the back: CB ("central back") or FB ("full back")
- EN 1621-3, level 1 or 2,

It is compulsory that all riders/passengers wear either suit or trousers, a long-sleeve shirt, chest and back protectors. incorporated within the suit or worn separately. It is strongly recommended to wear shoulder, elbow and knee protectors as well.

Riders can wear a complete leather/kevlar suit in one piece, with a minimum thickness of 1.2 mm, and with additional leather padding or other protection on the principal contact points (elbows, shoulders, fore-arms, hips, knees, etc.).

Moreover, it is compulsory that riders wear a back protector complying with EN 1621- 2, CB ("central back") or FB ("full back") level 1 or 2. Sections of the leather suit not directly subject to 'crash' damage may use a small limited area or strip not made of leather.

#### 1.2 Footwear

Footwear, in a good condition, made of leather or other materials having equivalent properties, shall be worn and have a minimum height of 30 cm.

#### 1.3 Helmets

It is compulsory for all participants taking part in practice and races to wear a protective helmet. The helmet must be properly fastened, be of a good fit, and be in good condition. The helmet must have a chin strap type 'retention system'.

- A protective lower face cover must be present and must be not detachable, not moveable.
- Helmets constructed with an outer shell made of more than one piece are not permitted (e.g. they must not contain any seam).
- A retention system with a strap and the double D ring closing system is recommended.
- All helmets must be marked with one of the official international standard marks mentioned below. Any FMN approval marks do not substitute the official international standard marks.
- A helmet is made to provide protection. It is not a platform to attach foreign objects. Cameras and/or other accessories are NOT permitted nor shall be attached to the rider's helmet. Failure to observe the above rules will entail exclusion. The helmets must comply with the FIM technical rules.

#### HELMET OPERATIVE INSTRUCTIONS

All helmets must be intact, and no alteration must have been made to their construction. After an accident involving impact the helmet must be presented to the technical steward for examination.

The chief technical steward and/or the technical steward may perform the following checks before the rider is permitted to take part in practice of the race: That the helmet fits well on the rider's head.

That it is not possible to slip the retention system over the chin, when fully fastened. That it is not possible to pull the helmet over the rider's head by pulling it from the back of the helmet.

If a helmet does not meet the technical requirements or is found to be defective, the technical steward clearly mark in red (e.g. with a red dot) all international marks without destroying them and retain the helmet until the end of the event. The rider must submit another helmet for approval by the technical steward. After an accident involving impact, the helmet must be presented to the technical steward.

### RECOGNISED INTERNATIONAL HELMET APPROVAL MARKS

Helmets must conform to one of the recognised international standards:

- EUROPE ECE 22.05 or ECE 22.06 (only "P" type)
- JAPAN JIS T 8133:2015 (only "Type 2 Full face")
- USA SNELL M2015 or SNELL M2020D or SNELL 2020R

Examples of labels are reported below (for Europe, the country numbers which have granted the approval are also indicated):

EUROPE	 <p><b>051406/P-1952</b>      <b>061406/P-1952</b></p> <p><small>1/ 1 for Germany, 2 for France, 3 for Italy, 4 for the Netherlands, 5 for Sweden, 6 for Belgium, 7 for Hungary, 8 for the Czech Republic, 9 for Spain, 10 for Yugoslavia, 11 for the United Kingdom, 12 for Austria, 13 for Luxembourg, 14 for Switzerland, 15 (vacant), 16 for Norway, 17 for Finland, 18 for Denmark, 19 for Romania, 20 for Poland, 21 for Portugal, 22 for the Russian Federation, 23 for Greece, 24 for Ireland, 25 for Croatia, 26 for Slovenia, 27 for Slovakia, 28 for Belarus, 29 for Estonia, 30 (vacant), 31 for Bosnia and Herzegovina, 32 for Latvia, 33 (vacant), 34 for Bulgaria, 35 (vacant), 36 for Lithuania, 37 for Turkey, 38 (vacant), 39 for Azerbaijan, 40 for The former Yugoslav Republic of Macedonia, 41 (vacant), 42 for the European Community (Approvals are granted by its Member States using their respective ECE symbol), 43 for Japan, 44 (vacant), 45 for Australia, 46 for Ukraine, 47 for South Africa and 48 for New Zealand. Subsequent numbers shall be assigned to other countries in the chronological order in which they ratify or accede to the Agreement Concerning the Adoption of Uniform Technical Prescriptions for Wheeled Vehicles, Equipment and Parts which can be Fitted and/or be Used on Wheeled Vehicles and the Conditions for Reciprocal Recognition of Approvals Granted on the Basis of these Prescriptions, and the numbers thus assigned shall be communicated by the Secretary-General of the United Nations to the Contracting Parties to the Agreement.</small></p>
JAPAN	 <p><b>JIS T8133:2015 Class 2</b>      Certification No. XXX000000      Label serial No. 000000000      XXX Manufacturer's name  <small>(Trade mark of certification body)</small></p>
USA	



### 1.4 Gloves

Riders shall wear gloves made of leather or other materials having equivalent properties.

### 1.5 Goggles

Riders must wear face shield/goggles. The use of glasses, helmet visors and 'tear offs' or 'roll offs' are also permitted. The material used for glasses, goggles and visors must be made of shatter-proof material. Helmet visors must not be an integral part of the helmet. Eye protectors which cause visual disturbance (e.g. scratched) must not be used.

## 2. FREEDOM OF CONSTRUCTION

A motorcycle must conform to the requirements of the FIM regulations as well as to several specific conditions that the FIM may require for certain competitions. No restriction is placed on the make, construction or type of motorcycle used.

All solo motorcycles must be constructed in such a way that they are entirely controlled by a rider. The use of titanium in the construction of the frame, the front forks, the handlebars, the swinging arms, the wheel- and swinging arm-spindles is forbidden. The use of light alloys for wheel spindles is also forbidden. The use of titanium alloy nuts and bolts is allowed.

#### *Carbon fibre*

The use of carbon fibre reinforced materials is authorised (with the exception of handlebars and wheel rims).

#### *Ceramic materials*

The use of ceramic parts is forbidden.

#### *Other equipment*

The use of data recording devices and automatic electronic ignition is authorised. No signal of any kind may pass between a moving motorcycle and any person, including radio and bluetooth communication. The exception is for the signal from the time keeping transponder, automatic lap timing devices or from the approved onboard cameras (with prior written approval from the FIM).

#### *Number of cylinders*

The number of cylinders in an engine is determined by the number of combustion chambers. If separate combustion spaces are used, they must be connected by an unrestricted passage of minimum cross-sectional area at least 50 % of the total inlet port area.

### **3. DEFINITION OF A FRAME OF A SOLO MOTORCYCLE**

The structure or structures used to join any steering mechanism at the front of the machine to the engine/gear box unit and to all components of the rear suspension.

### **4. STARTING DEVICES**

Starting devices for the engine are permitted.

### **5. FUEL TANKS**

The fuel tank and fuel cap must always be leak proof. Fuel tanks shall only be filled in the paddock or pit lane.

Additional fuel tanks are allowed provided that:

- they are made by an approved company
  - they must be firmly fixed
  - hose connections must be leak-proof
- they must be protected against projections
- they are not placed **in front or** above the handlebar

Additional fuel tanks must be presented - already mounted - for inspection at the technical verifications.

### **6. OPEN TRANSMISSION GUARDS**

A guard must be fitted to the countershaft sprocket.

If the primary transmission is exposed, it must be fitted with a guard as a safety measure. The guard must be designed so that rider or the passenger cannot under any circumstances come into accidental contact with the transmission parts. It must be designed to protect the rider from injuring his fingers.

A chain guard must be fitted in such a way to prevent trapping between the lower chain run and the final driven sprocket at the rear wheel.

### **7. EXHAUST PIPES AND SILENCERS**

Exhaust pipes and silencers must fulfil all the requirements concerning sound control

The axis of the silencer end must be parallel (tolerance 15°) to the two principal longitudinal planes of the vehicle. The extremity of the silencer must not pass the vertical tangent of the rear tyre. The edge of the silencer shall not be dangerous in case of accidental contact with theriders or helpers. If the final tube protrudes more than 3 mm, the edge must be rolled to an angle of 180° or radiused (see pictures below). In both cases, the edgethickness shall be 3 mm minimum.

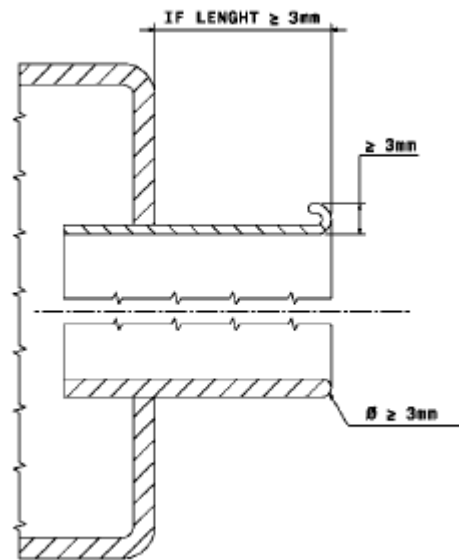

Exhaust fumes must be discharged towards the rear but not in such a manner as to raise dust, foul the tyres or brakes, or any other rider.

## 8. HANDLEBARS

The width of handlebars must be not less than 600 mm and not more than 850 mm (see diagrams).

The handlebars must be equipped with a protection pad on the cross bar. Handlebars without a cross member must be equipped with a protection pad located in the middle of the handlebars, covering widely the handlebars clamps.

Handlebar clamps must be very carefully radiused and engineered to avoid any fracture points in the handlebar.

Exposed handlebar ends must be plugged with a solid material or rubber covered.

When hand protectors are used, these must be made of a shatter-resistant material and have a permanent opening for the hand.

Handlebars made of composite materials are not authorised. Repair by welding of light alloy handlebars is prohibited.

Solid stops (when on full-lock, other than steering dampers) must be fitted. These must ensure a minimum clearance of 30 mm between the handlebar with levers and the tank to prevent trapping the rider's fingers.

## 9. CONTROL LEVERS

All handlebar levers (clutch, brake, etc.) must be in principle ball ended (diameter of this ball to be at least 16 mm, see diagrams). This ball can also be flattened, but in any case the edges must be rounded (minimum thickness of this flattened part 14mm). These ends must be permanently fixed and form an integral part of the lever. If the gear lever consists of a tube, then its edge must be rounded. Each control lever (hand and foot levers) must be mounted on an independent pivot.

The brake lever if pivoted on the footrest axis must work under all circumstances, such as the footrest being bent or deformed.

Hand- and foot-controls may be modified for mobility challenged riders.

## 10. FOOTRESTS

Footrests must comply with all the following:

- fixed to the original mounting position on the frame provided by the manufacturer
- not lower than the frame or the lowest part of the engine
- footrest end must be rounded, at least 8mm radius
- no 'Speedway' or 'Long Track' type footrest is allowed

### 11. MUDGUARDS AND WHEEL PROTECTION

Motorcycles must be fitted with rounded mudguards. Mudguards must project laterally beyond the tyre on each side.

Mudguards must be made of flexible materials only (e.g. plastics).

### 12. STREAMLINING

No type of streamlining is allowed.

Radiator covers (shields) must be made of flexible materials only (e. g. plastics).

### 13. SUSPENSION

Electronically controlled suspension systems must not be used.

### 14. WHEELS, RIMS, TYRES

The front and rear rim size shall be 19 inches.

Any modification to the rim or spokes of an integral wheel (cast, moulded, riveted) as supplied by the manufacturer, or of a traditional detachable rim other than for spokes, valve or security bolts, is prohibited. The only exception made is for tyre retention screws, sometimes used to prevent tyre movement relative to the rim. If the rim is modified for these purposes, bolts, screws, etc., must be fitted. The original (moulded) flat track tyre tread pattern cannot be cut or modified. Handcut tyres are not permitted. MX, Trial, Enduro and Track Racing type tyres are not permitted.

### 15. CAPACITY

The following engine capacities are allowed on the FIM Flat Track rounds:

- Two strokes: over 250cc up to 500cc, single cylinder engines
- Four strokes: over 250cc up to 450cc, single cylinder engines
- All engines must be connected to a properly fastened oil catch tank of 0.2 litres minimum capacity or have a closed breather system (engine breather system connected to the airbox).

#### *Measurement of the capacity*

Reciprocating movement engine, "Otto" cycle

The capacity of each engine cylinder is calculated by the geometric formula which gives the volume of a cylinder; the diameter is represented by the bore, and the height by the space swept by the piston from its highest to lowest point:

$$\text{Capacity} = \frac{D^2 \times 3.1416 \times C}{4} \quad \text{where } D = \text{bore and } C = \text{stroke}$$

When a cylinder bore is not circular, the cross-sectional area must be determined by a suitable geometrical method or calculation, then multiplied by the stroke to determine capacity. When measuring, a tolerance of 1/10 mm is permitted in the bore. If with this tolerance the capacity limit is exceeded for the class in question, a further measurement should be taken with the engine cold, to 1/100 mm limits.

#### *Rotary engines*

The capacity of an engine which determines the class in which the motorcycle shall compete in a meeting shall be calculated by:

$$\text{Capacity} = \frac{2 \times V}{N} \quad \text{where } V = \text{total capacity of all the chambers comprising the engine and}$$

N = number of turns of the motor necessary to complete one cycle in a chamber classified as a 4-stroke.  
Wankel system

For Wankel system engines with a triangular piston, the capacity is given by the formula:

Capacity = 2 x V x D, where V = capacity of a single chamber and D = number of rotors.

This engine is classified as a 4-stroke.

## 16. SUPERCHARGING

Supercharging by means of a device of any kind is forbidden in all meetings. An engine, whether 2-stroke or 4-stroke, coming within any one of the recognized classes (determined by the capacity of the working cylinder) shall not be considered as supercharged when, in respect of one engine cycle, the total capacity measured geometrically, of the fuel charging device or devices, including the capacity of the working cylinder (if used for injecting the fuel), does not exceed the maximum capacity of the class in question.

## 17. TELEMETRY

Information must not be transmitted in any way to or from a moving motorcycle.

An official signalling device may be required on the machine.

Automatic lap timing devices are not considered as "telemetry".

Automatic lap timing devices must not disrupt any official time keeping methods and equipment.

## 18. NUMBER PLATES

Number plates must be made of flexible materials only (e.g. plastic). Number plates are required as follows:

- One (1) front number plate, mounted on the top section of the front forks and the riders' riding number on the back of the rider
- Two (2) number plates, one (1) mounted on each side of the motorcycle behind the rider
- Number plate dimensions are: 25 cm x 30 cm (height x length)

- **Colours: black numbers on a yellow background.**

**Background color: RAL 1023**

**Numbers minimum height: 120mm**

**Numbers color: black**

**Flat Track logo is **COMPULSORY****



One plate must be fixed to the front inclined not more than 30° towards the rear from the vertical plane. Holes can be perforated between the numbers on the numberplate. However, under no circumstances must the actual numbers be perforated. The following minimum dimensions must be respected on the front number plate:

- Height of the number 140 mm
- Width of each number 70 mm
- Width of the stroke 25 mm
- Space between two numbers 15 mm
- Space between the FIM logo and the number 10 mm

## 19. NUMBER SASHES

Starting numbers to be worn on sashes (bibs) or printed on the riders' jersey must be conforming to the following:

The colour of the number must be in strong contrast with the colour of the background. The number may be outlined. The colour of the outlining must contrast with the background color as well as the number colour (ex: a white jersey with orange numbers could use a black outline).

Distance between the numbers: 1.5 cm.

Height of number: minimum 20 cm.

Width of number: minimum 10 cm for one-digit numbers minimum 20 cm for two-digit numbers - minimum 25 cm for three-digit numbers.

Width of stroke: 3 cm.

Minimum free space around the number without publicity: 5 cm.

Starting numbers used by riders on number sashes or tee-shirts must follow the starting number of the race in question. Furthermore, the numbers must be worn during the practices as well as during the races.

## 20. IGNITION CUT-OUT SWITCHES

Motorcycles must be equipped with a functional ignition kill switch or button mounted on either right or left side of handlebar (within reach of the hand while on the hand grips) that stops a running engine. The ignition cut-out switch may also be fitted on the handlebar, as close as practicable to the throttle.

The lanyard must be made of a non-elastic material and must remain attached to the wrist of the rider, mechanic or support team member always the motorcycle is under power, including, but not limited to, during warm up, in the pits, in the competition area or any public area. The ignition cut-out must stop the engine immediately, by the simple action of pulling a lanyard or a non-elastic string (which must be as short as possible) attached to the rider's right wrist.

All other engine management switches and electrical connectors must remain covered or closed during riding.

## 21. BRAKES

Front wheel brakes are only compulsory for TT meetings.

In all other Flat Track classes of competition front brakes are prohibited and all components relating to the front brake must be removed. The rear wheel must have an efficient brake system.

- A safety device (pin or lock nut) should be installed on the brake pad fixture.
- The safety wire used on the bolts of the brake callipers must be visible.

## 22. FUEL

All vehicles must be fuelled with

- unleaded gasoline (from public pump station or race type)

OR

- a mixture of unleaded gasolines

OR

- a mixture of unleaded gasoline(s) and lubricant in the case of 2-stroke engines.

The unleaded gasoline or the mixture of unleaded gasolines used must comply with the FIM specifications. The mixture of unleaded gasoline(s) and lubricant must comply with the FIM specifications. Riders/teams must declare to the FIM technical director (or the FMNR chief technical steward when there is no FIM technical director appointed) the make and type of gasoline to be used during practices and race(s), upon presentation of the rider/team's motorcycle(s) at the initial technical verifications. They are also recommended to provide a certificate issued by the gasoline company which certifies that the gasoline has been tested and is in conformity with FIM specifications.

Gasoline companies which supply 'race' gasolines (gasolines other than those obtained at public pump stations) to participating teams/riders must test their gasoline at Intertek Schlieren (Switzerland) against all the FIM specifications.

Providing the gasoline is within the FIM specifications, a certificate containing a test report and batch number will be issued to the fuel company. The gasoline company shall be able to provide a copy of such certificate to their client rider/teams before they take part in a race.

Contact for fuel analysis: [fimfuels@intertek.com](mailto:fimfuels@intertek.com).

A list of gasolines which are in conformity with FIM specifications will be published by FIM on the FIM website.

Furthermore, in the cases in which only gasoline from the appointed supplier is permitted (for a specific event or the entire World championship, prize or cup), the aforementioned gasoline shall have been previously tested in a FIM appointed laboratory in order to test its conformity with the FIM specifications:

- in case of conformity, a certificate of conformity (including test report and tested batch number) shall be available and art. 01.63 applies in case of controls for the riders/teams;
- in case the conformity is not achieved, the FMN of the organizing country/the organiser shall ask the FIM for a waiver to enable the use of gasoline not corresponding to FIM specifications. If the waiver is granted, the riders/teams will be responsible for using the gasoline provided without changing its composition. Controls may be carried out by FIM.

FIM specifications for unleaded gasolines or mixtures of unleaded gasolines.

The following specifications are set for unleaded gasoline or the mixture of unleaded gasolines:

The following properties shall be within the following thresholds (for each property, the relative test methods to be used for the measurement are indicated):

Property	Units	Min.*	Max.*	Test Method
RON		95.0	102.0	EN ISO 5164 or ASTM D2699
MON		85.0	90.0	EN ISO 5163 or ASTM D2700
Oxygen (includes 10% ethanol allowance)	% (m/m)		3.7	EN ISO 22854 <sup>1</sup> or EN 13132 or elemental analysis
Nitrogen	% (m/m)		0.2	ASTM D 4629 <sup>2</sup> or ASTM 5762
Benzene	% (V/V)		1.0	EN ISO 22854 or ASTM D6839 or ASTM D5580
Vapour pressure (DVPE)	kPa		100.0	EN 13016-1 or ASTM D5191
Lead	mg/L		5.0	ICP-OES or AAS
Manganese	mg/L		2.0	ICP-OES or AAS
Density at 15°C	kg/m <sup>3</sup>	720.0	785.0	EN ISO 12185 or ASTM D4052
Oxidation stability	minutes	360		EN ISO 7536 or ASTM D525
Sulphur	mg/kg		10.0	EN ISO 20846 or ASTM D5453
<u>Distillation:</u>				EN ISO 3405 or
				ASTM D86
E at 70°C	% (V/V)	20.0	52.0	
E at 100°C	% (V/V)	46.0	72.0	
E at 150°C	% (V/V)	75.0		
Final Boiling Point	°C		210	
Residue	% (V/V)		2.0	
Appearance	clear, bright and visually free from solid matter and undissolved water			Visual inspection
Olefins	% (V/V)		18.0	EN ISO 22854 or ASTM D6839
Aromatics	% (V/V)		35.0	EN ISO 22854 or ASTM D6839
Total diolefins	% (m/m)		1.0	GC-MS or HPLC
<u>Oxygenates:</u>				EN ISO 22854 <sup>1</sup> or EN 13132
Methanol	% (V/V)		3.0	The only oxygenates permitted are paraffinic mono-alcohols and paraffinic mono-ethers (of 5 or more carbon atoms per molecule) with a final boiling point below 210°C.
Ethanol	% (V/V)		10.0	
Isopropanol	% (V/V)		12.0	
Isobutanol	% (V/V)		15.0	
<i>tert</i> -Butanol	% (V/V)		15.0	
Ethers (C5 or higher)	% (V/V)		22.0	
Others	% (V/V)		15.0	

2 In cases of dispute ASTM D 4629 will be the reference method.

a) All reported min. and max. thresholds do not include the tolerance, which needs to be calculated in accordance with ISO 4259 and considered to correct the min. and max. thresholds.

b) The total of individual hydrocarbon components presents at concentrations of less than 5% (m/m) must constitute at least 30% (m/m) of the fuel. The test method will be GC-FID (gas chromatography-flame ionisation detector) and/or GC-MS (gas chromatography-mass spectrometry).

c) The total concentration of naphthenes, olefins and aromatics classified by carbon number must not exceed the values given in the following table:

% (m/m)	C4	C5	C6	C7	C8	C9+
Naphthenes	0	5	10	10	10	10
Olefins	5	20	20	15	10	10
Aromatics	-	-	1.2	35	35	30

Bicyclic and polycyclic olefins are not permitted. The fuel must contain no substances which are capable of exothermic reaction in absence of external oxygen.

FIM specifications for mixtures of unleaded gasoline(s) and lubricant

The lubricant:

- must not change the composition of the gasoline fraction when added to the gasoline;
- must not contain any nitro-compounds, peroxides or any other engine power boosting additives;
- must in no way contribute to an improvement in overall performance;
- during the distillation up to 250°C, must not show a reduction in mass by evaporation of more than 10% (m/m) (test method: simulated distillation GC);
- must contain a max. content of anti-knock agents (lead, manganese, iron) of 10 mg/Kg (test method: ICP-OES).

Moreover, the following specifications are set for the mixture of unleaded gasoline(s) and lubricant:

The following properties shall be within the following thresholds (for each property, the relative test methods to be used for the measurement are indicated):

Property	Unit	Min.	Max.	Test Method
RON			102.0*	EN ISO 5164 or ASTM D2699
MON			90.0*	EN ISO 5163 or ASTM D2700
Density at 15°C	kg/m <sup>3</sup>	690**	815**	EN ISO 12185 or ASTM D4052

\*Reported min. and max. thresholds do not include the tolerance, which needs to be calculated in accordance with ISO 4259 and taken into account to correct the min. and max. thresholds.

\*\* Min. and max. thresholds do include the tolerance.

### *Air*

Only ambient air may be mixed with the fuel as an oxidant.

### *Sampling and Testing*

The FIM may require gasoline controls, i.e. controls of the unleaded gasoline, mixture of unleaded gasolines or mixture of unleaded gasoline and lubricant, used by riders/teams at events. These controls involve an initial sampling at the event and further testing in the FIM appointed laboratory.

#### *Sampling*

- 1) The FIM technical director (or the FMNR chief technical Steward when there is no FIM technical director appointed) is the sole official responsible for the sampling management and supervision.
- 2) Riders/teams selected for gasoline controls are directed to proceed with their vehicles to the area that has been designated for this purpose.
- 3) The FIM technical director /FMNR chief technical steward collects the gasoline from the motorcycle by using only new sample containers and pipettes/hand pumps.  
The gasoline is transferred using the pipette/hand pump directly from the gasoline tank into three containers, denominated A, B and C. The containers are closed and sealed by the FIM technical director/FMNR chief technical steward.
- 4) The FIM technical director /FMNR chief technical steward fills in (in all its parts) and signs the gasoline sample declaration form (see 63.04.03). The rider or a team representative also signs this form, after verifying that all the information is correct.
- 5) The FIM technical director/FMNR chief technical steward prepares an appropriate shipping box containing the collected A, B and C samples and a copy of the respective, signed, gasoline sample declaration form. The box is then shipped to the FIM appointed laboratory by registered courier.

#### *Testing*

- 1) One or more properties to be checked (following the relevant testing method) are set by the FIM for each selected rider/team. 2) Sample A is the first sample to be tested by the FIM appointed laboratory.
- 3) Sample B can be used for a second analysis if required by the FIM. The test result of the A or B sample more favourable to the rider/team is considered. Costs for the shipping and testing of sample A and B are paid by FIM.
- 4) As soon as possible after completing the testing, the FIM appointed laboratory reports the test results directly to the responsible CTI coordinator.
- 5) For negative cases (i.e. conformity of the tested property(ies) with the specification), the riders/teams concerned will be individually informed by the FIM in due course, copying the rider/team's FMN, the FIM

technical director/FMNR chief technical steward, the competent authority (e.g. international jury), the CTI director, the director and coordinator(s) of the sporting commission concerned.

6) Only for positive cases following testing of sample A or B or A and B (i.e. nonconformity of one or more properties\*), the responsible CTI coordinator notifies by electronic mail\* the rider/team concerned (including the testing results) and, 24 hours after, forwards the relevant information to the rider/team's FMN, the FIM technical director/FMNR chief technical steward, the competent authority (e.g. race direction, international jury), the CTI director, the director and coordinator(s) of the sporting commission (s) concerned. \*Note: The non-conformity of one property (except the Appearance) is enough for declaring non-conformity of the gasoline or the mixture.

If the rider/team wishes to request a counter-expertise, he must notify the responsible CTI coordinator by electronic mail\* accordingly, within 72 hours of receipt by the FIM of the delivery status notification pertaining to the notification of the test results to the rider/team.

- If a counter-expertise is requested, the sample dedicated to the counterexpertise is sample C and the test shall aim at checking the same property(ies) previously checked on sample A/B. The rider/team can request that sample C be tested at one of the available FIM appointed laboratories. Costs for shipping and testing of sample C are paid by the rider/team concerned.

Upon notification of the sample C results, the responsible CTI coordinator notifies by electronic mail\* the rider/team concerned (including the testing results) and forwards the relevant information to the rider/team's FMN, the FIM technical director/FMNR Chief technical steward, the competent authority (e.g. race direction, international jury), the CTI director, the director and coordinator(s) of the sporting Commission concerned.

- If no counter-expertise is requested within the time limit, the responsible CTI coordinator forwards the relevant information by electronic mail\* the rider/team's FMN, the FIM technical director/FMNR Chief technical steward), the competent authority (e.g. race direction, international jury), the CTI director, director and coordinator(s) of the sporting commission concerned.

8) The competent authority of the event concerned (e.g. race direction, international jury) takes a decision based on the information received. The coordinator of the sporting commission concerned notifies the rider/team concerned regarding the decision by electronic mail\*.

The non-conformity of the

- A sample (in the cases B sample was not used) or
- B sample (in the cases A sample result was not conclusive) or
- A and B samples or
- A and B and C samples (in the cases B sample was used and a counterexpertise was requested) or
- A and C samples (in the cases B sample was not used and a counterexpertise was requested),
- automatically results in the disqualification of the rider/team from the entire event.

No disqualification will be applied in case of conformity of sample C. Furthermore, in any case, other penalties may be applied.

The rider/team has the right to appeal against the decision of competent authority of the event concerned (e.g international jury) in accordance with FIM disciplinary and arbitration code applicable to the relevant discipline.

\*The receipt of a delivery status notification will be deemed as proof of delivery.

### **23. CARBURATION SYSTEMS**

Any fuel injection system or carburetion is permitted. The ECU may be modified or replaced with an aftermarket model only with the purpose of changing fuel mapping and ignition settings. Wiring harness, spark plugs, plug wires and spark plug caps may be replaced.

### **24. ENGINE AND THROTTLE CONTROLS**

Only the engine stops (cut-out switch) may be fitted on the handlebar. The engine stop switch (connected through a lanyard to the riders' wrist) must be fitted to the ignition system of the machine.

All other engine management switches and electrical connectors must remain covered or closed during the competition.

## 25. GEAR BOX

The gear box itself must be fully integrated with the engine. A separate gear is not permitted. Only foot operated gearbox changes are permitted. Electric or electronically assisted gearbox or gearbox lever changing mechanisms are not permitted.

### *BADGE OF THE FIM*

Under certain circumstances the FIM may permit the use of the FIM badge on certain equipment to show that the latter conforms to the standards laid down by the FIM. When this authorisation is granted and provided the equipment on which it appears is in good condition, the badge is then the guarantee of the conformity with the standard set by the FIM.

## 26. TECHNICAL VERIFICATIONS

Prior to any practice or racing all motorcycles will be checked to ensure the compliance with the technical rules.

All motorcycles entered in the event must comply with these regulations and the supplementary regulations, whether the intention is to use the motorcycle or not. Any rider not complying with the regulations will be disqualified from the race and his motorcycles removed from the pits.

- Before the start of the competition, a closed and guarded area (closed parc/parc-fermé) shall be prepared.
- Inspection must take place under cover with a large enough area.
- Inspection area must be supplied with the necessary equipment, including tables, chairs, electric light and power outlet.

*The necessary tools are listed below:*

Revolution meter

Sound meter, calibrator and spare batteries

Slide calliper (for verifying engine capacity, carburettor diameter, etc.)

Depth gauge

Steel measuring tape

Seals

Tools for measuring the engine capacity

Lampoil tester is recommended and when used, it indicates the cylinder capacity. When a more precise measurement is required, the chief technical steward may ask to take the cylinder head off the cylinder.

Colour for marking parts

Heat resistant stickers or paint for marking the silencer (and solvent)

Magnet

Adequate fuel sample bottles

PC with CD drive + updated operating system

Printer, etc. are recommended

Calculator

*The necessary documents are listed below:*

Supplementary regulations

FIM technical rules - current year

FIM rules of the discipline concerned

FIM sporting code

Homologation papers (if applicable)

Writing material

*Technical verifications forms*

All necessary measures and administrative equipment should be in place at least 1/2 hour before the start of the technical verifications is due to open (time in supplementary regulations).

The technical verifications before the official practice should last at least 30 min, before the race at least one hour, after the race last at least 30 min.

The technical control must be carried out in conformity with the procedure and times fixed in the CCP rules and the supplementary regulations of the event.

- The sound control must be carried out first. The sound level will be recorded in the technical card. The exhaust silencer will be marked with paint or sticker.

An overall inspection of the motorcycle must be carried out in conformity with the FIM rules. Accepted

motorcycles will be marked with paint or a sticker.

- The technical verifications will be recorded on the technical verifications form.
- During the event, the technical steward must control all machines and equipment. This control must be made before the machines enter onto the track.
- As soon as a rider has finished all his heats, all used machines must be immediately placed in a closed park where they must remain for 30 minutes, in case of a protest or should further examination be required.
- Competitors must retrieve their machines within 30 minutes after the opening of the closed park area, except for the machines which are chosen for disassembly. After this time limit, the closed park officials will no longer be responsible for the machines left behind.
- If required, a sound level control may be carried out before the machines are placed in the closed park.
- For the technical verifications taking place after the race, it shall be ensured that the selected machines used during the race go directly to the parc fermé.

#### *FMNR chief technical steward and technical stewards*

- The chief technical steward must attend an event one hour before the technical verifications are due to begin. He must inform the clerk of the course and FIM technical director, if present, of his arrival.
- The chief technical steward must ensure that all technical stewards appointed for the event carry out their duties in a proper manner. The chief technical steward shall appoint the technical stewards to individual posts for the race, practices and final control.
- Scrutineers can have different tasks, but the team of scrutineers must have a minimum of three persons. The FMNR chief technical steward must be a holder of an FIM SENIOR technical stewards Licence and it is recommended that at least one technical steward hold a FIM technical stewards Licence.

A minimum number of scrutineers is required according to the following:

- Checking of documentation: one

- Sound test, silencer marking: two

- Machine inspection, helmet and clothing: two

- The sound control officer (SCO) must be holder of a valid FIM technical steward's license, come with good knowledge and experience of the sound control and application of the test method. The FMNR may propose the services from a special technician (acoustic engineer) if there is no FIM licenced technical steward available to act as SCO.
- The technical steward must fill in the technical card which must be signed by the rider.
- If a motorcycle is involved in an accident, the technical steward must check the machine to ensure that no defect of a serious nature has occurred.
- If the helmet is clearly defective, the technical steward must retain it. The organiser must send this helmet, together with the accident and medical report (and pictures and video, if available) to the federation of the rider. If there are head injuries stated in the medical report, the helmet then must be sent to a neutral institute for examination.
- The chief technical steward has the right to look/ inspect any part of the motorcycle at any time of the event.
- All technical stewards shall be well informed and shall make sure their FMN has supplied them with all technical "updates" that may have been issued after the printing of the technical rulebooks.

#### *Rider and/or mechanic*

- The rider and/or the mechanic and/or team manager must attend at least once the technical verifications with the (rider's) machine within the time limits stated in the supplementary regulations.
- On request of the technical steward, the rider must present themselves to the technical verifications. The maximum number of persons present at the technical verification will be the rider and/or the mechanic and/or team manager.
- A rider remains at all times responsible that his machine and his personal protective gear are in conformity with the FIM technical rules for Track Racing motorcycles.
- The rider and/or the mechanic and/or the team manager must present a clean motorcycle in conformity to the FIM rules.
- The rider is permitted to use whichever motorcycle he chooses from the accepted motorcycles. He may also use the motorcycle of another rider.

The rider and/or the mechanic and/or the team manager must present the rider's protective wear (equipment), e.g. helmet and bib with prescribed starting number.

- Any rider failing to report as required by the provisions below may be excluded from the meeting.
- The clerk of the course may prohibit any person who does not comply with the rules, or any rider who could be a danger to other participants or to spectators, from taking part in the competitions.

## **27. DANGEROUS MACHINES**

If, during practice or the race, a technical steward finds that a machine is defective and might constitute a danger to other riders, he must immediately notify the clerk of the course or his deputy. It is their duty to exclude such a machine either from the practice or from the race itself.

## **28. SOUND LEVEL CONTROL**

NOTES:

- EPVs (group J) are exempted from sound level control.
- For the first World championship event, all competitors' machines will be checked for sound level. After the first event, the machine of a 'wild card-' or 'one event' rider will be checked for the sound level, as well as any other rider's machine on a random basis.
- Excessively loud machines must always be checked, regardless of the participants' status.

To pursue the measures taken to reduce the sound level in favour of environment and in the framework of the 'RIDE QUIET' campaign, a new method for measuring the sound level called "2 metre max" is applied as from 2013 in all 'allterrain' disciplines.

The technical specifications and the resources to apply such a method, for the use of the technical stewards and officials, are outlined in the present article.

The "2 metre max" method shows a very good correlation between the sound power level (L<sub>WA</sub>) issued by motorcycles in full acceleration, and the maximum sound pressure levels measured at proximity of the same motorcycles, with engines at idle and quickly taken to their maximum rotational speeds.

The "2 metre max" method will consist in quantifying not only the sound level produced by the silencer of the exhaust, but the maximum global sound level achieved by the motorcycle when the engine rpms are raised to the maximum engine speed, limited by a natural regulation (for 2 strokes) or rev limiters (for 4 strokes). Only the sound levels measured with the "2-meter max" method will be considered by the technical stewards and by the race direction/jury of the event to decide whether the motorcycle is in conformity with the maximum sound levels authorised.

### *Preparation of the sound meter*

For all FIM championships and prices, all sound meters must have a frequency response according to IEC61672 section 11 within a limit of plus or minus 2 dBA from 125 to 8000 Hz at 94, 104 and 114 dBA.

Sound level measuring equipment must also include:

- a compatible calibrator, which must be used immediately before testing begins and always just prior to a re-test if a disciplinary sanction may be imposed;
- a tachometer.

Two sets of equipment must be available in case of failure of tachometer, sound level meter or calibrator during technical control.

The sound meter shall be prepared by applying the following procedure:

- Activate the 'A' weighing
- FAST time weighting must be activated
- Select the highest range available (ex. 80~130 dB)
- Calibrate the sound meter according to the instructions, considering the incidence of the wind foam ball
- Position the wind foam ball on the microphone
- Activate the function MAX MIN – set on MAX

Set up of the sound meter and the motorcycle

The sound levels will be measured with the microphone fixed on a tripod at a height of 1.35 m above the ground, in horizontal (levelled) position. It is helpful to have the microphone equipped with an extension cable to the sound meter.

For the place and position of the vehicle, ensure that there are no solid obstacles within 10 m around the microphone.

Depending on the vehicle, the sound meter will be positioned - for Solo motorcycles at an angle of 45° from the longitudinal axis of the vehicle, on the exhaust side, at 2 m behind the vehicle (measured from the point where the centre of rear tyre touches the ground) for solo motorcycles with 2 exhaust outputs: at an angle of 45° from the longitudinal axis of the vehicle, on the side of the air intake, at a distance of 2 m behind the vehicle (measured from the point where the centre of rear tyre touches the ground). Note: if a central positioned air intake is used, both sides will be tested.

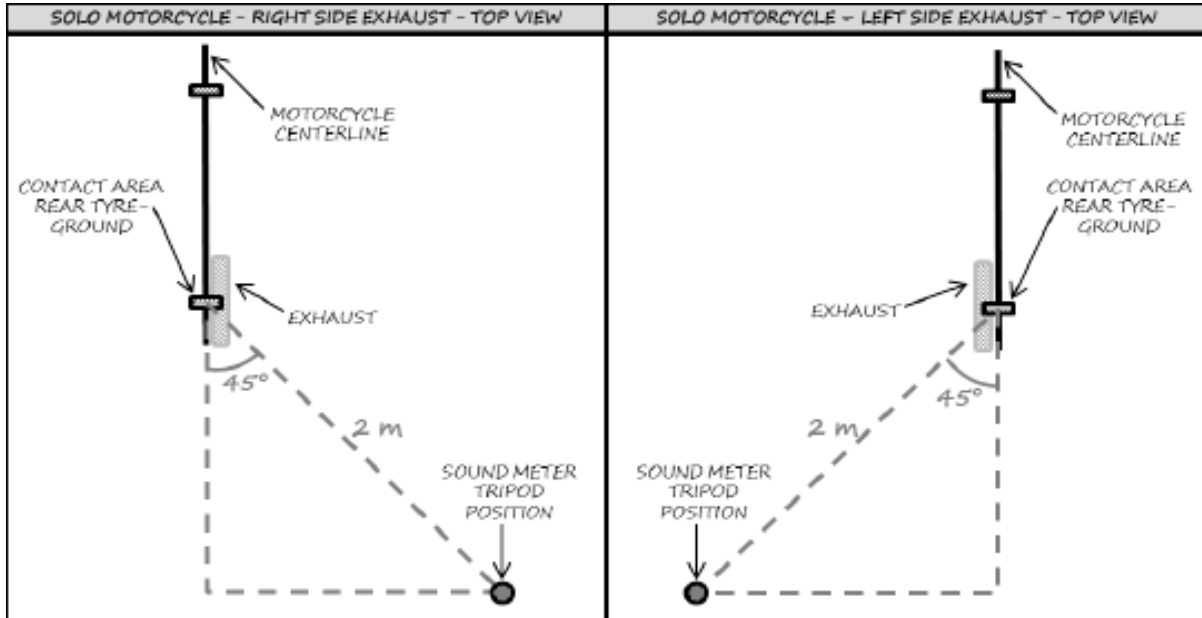

Silencers fitted with adapters aiming to reduce the sound level shall be permanently fitted.

To make repetitive measurements, all motorcycles can be positioned into a small frame fixed on the ground, making sure to respect the 45° requirements. A squared frame helps the positioning of the motorcycle

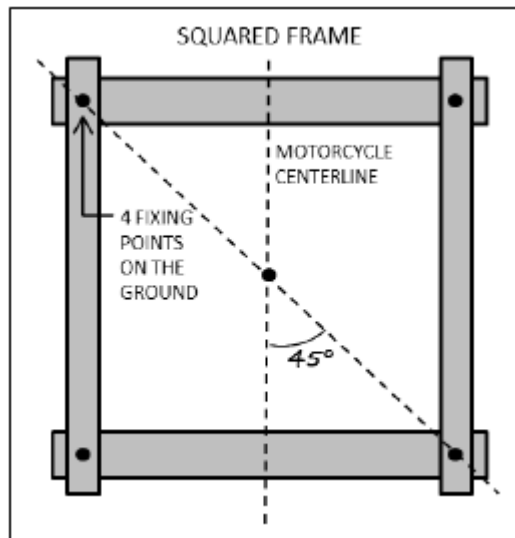

Vehicles which are not equipped with a gear box neutral must be placed on a stand. It is preferred to make the tests on soft ground, not reverberating, i.e. grass or fine gravel.

In other than moderate wind, machines should face forward against the wind direction.

The ambient sound at the point of measurement must be minimum 15 dBA less than the lowest FIM sound limit applied in each discipline.

It is recommended to regularly re-calibrate the sound meter during the test day.

### The test procedure

A technical steward (nominated as sound control officer, "SCO", see 77.03) takes place next to the vehicle, opposite to the sound meter/microphone, in order not to screen or stand between the bike and the microphone.

The sound control officer (SCO) must have arrived in enough time for discussions with the clerk of the course and other technical officials in order that a suitable test site and testing procedure can be agreed. A second technical steward can be present to help. The rider can also be present. It is strongly advised that the technical steward(s) use earplugs, a headset or ear protectors.

The measurement is made with motorcycle on its wheels, with a hot engine. During the sound test, only the rider may sit on the vehicle in the normal riding position. A rider or a mechanic, placed on the left side of the motorcycle, shall disengage the clutch.

The SCO (and not others) shall open the throttle as fast as possible (instantly, within 0.3 s) until "full open throttle", to reach the maximum rpm value ("max. rpm"). When in doubt, it can be verified that such "max. rpm" value is higher than the rpm value at which the vehicle supplies its maximum power (kW) ("max. power rpm").

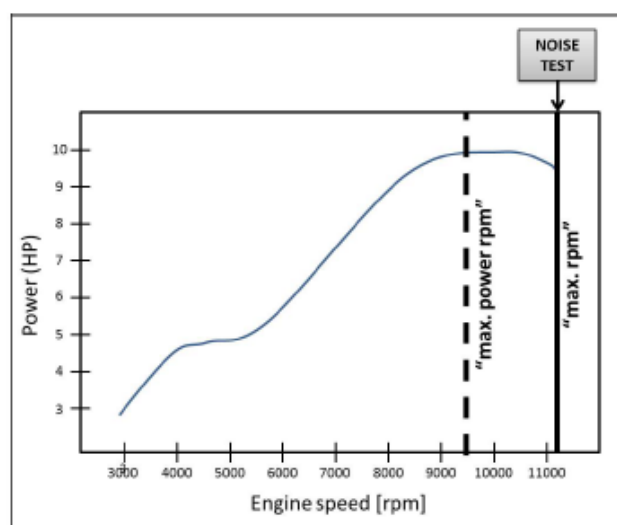

To conclude the test, the SCO releases the throttle quickly. The maximum noise value (dB/A) registered during the measurement interval is then read on the sound meter and recorded. This noise value shall not be rounded down to the nearest whole number.

The noise value is then compared with the sound limits. The noise test can be "PASSED" or "NOT PASSED":

- "PASSED": The sound test is considered "passed" if the recorded noise value is below or equal to the sound limits. The silencer can then be marked by the SCO at the end of the test. The silencer shall not be changed after verification, except for the spare silencer that has also been checked and marked. The end opening of the silencer shall remain unmodified once it has been checked and marked.
- "NOT PASSED": The sound test is considered "not passed" if the recorded noise value is above the sound limits. In this case, the vehicle (with the same silencer) can be presented again, but for two more tests maximum. If the third test result is negative, the rider:
  - can present a different or repaired silencer (in case the sound test was done, before the race)
  - will receive a penalty (in case the sound test was done during or after the race).

The sound meter is then reset by pushing on the sideline and armed by pushing on the sideline again.

### Notes:

- If the engine starts to misfire, close the throttle slightly and re-open the throttle.
- If detonations appear, the measurement must be started again.
- For vehicles without an engine rev. limiter, the throttle will have to be opened not more than 2 s or until there is an audible sign of over-revving the engine.

- Even in case a vehicle has not exceeded the respective sound limit, if there is any doubt, the vehicle may be checked again.
- If the vehicle is unable to reach the "max. power rpm" value, the vehicle shall be refused. Any attempt by a participant to prevent his engine from reaching the "max. power rpm" will be considered a breach of the rules.
- In case the SCO doubts that the "max. power rpm" value (as declared by the manufacturers or previously obtained with the dyno test), he/she shall measure the engine speed with a tachometer connected to the spark.

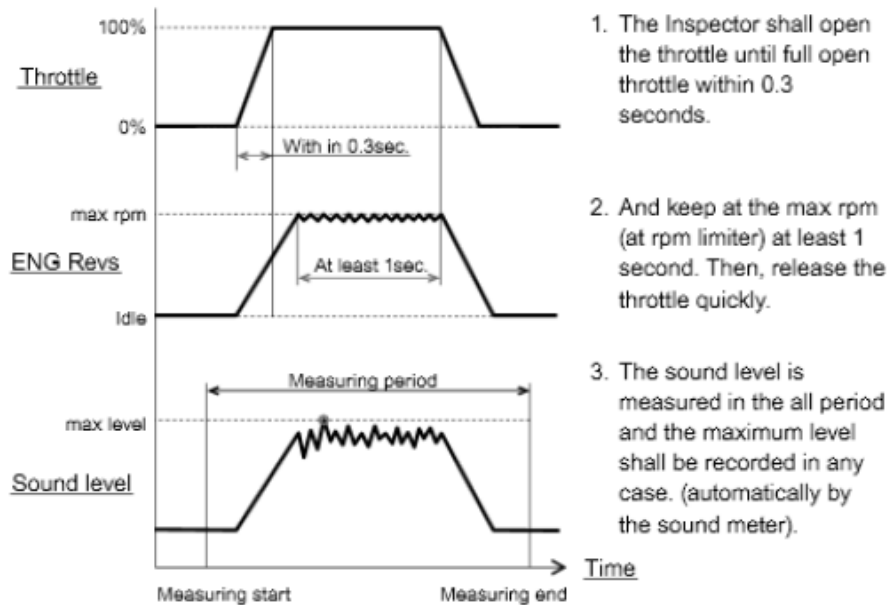

1. The Inspector shall open the throttle until full open throttle within 0.3 seconds.
2. And keep at the max rpm (at rpm limiter) at least 1 second. Then, release the throttle quickly.
3. The sound level is measured in the all period and the maximum level shall be recorded in any case. (automatically by the sound meter).

Sound limits: 114.0 dB/A before the race and 115.0 after the race.

**NOTES:**

- The values that must be respected after the race take into account the degradation of the silencer (i.e. the limit is raised of 1 dB/A).
- The values already consider the accuracy of the method.
- No deductions for ambient temperature, pressure or altitude are allowed.

*Spare silencers*

The rider or the mechanic can present at the sound control, together with the vehicle, one (1) spare silencer to be checked. Other spare silencers may be presented after all participants have presented their vehicles, or on the following days of the event. Action and decisions will depend on the sporting discipline concerned, and decisions taken during prior discussions with the FIM technical director and/or the chief technical steward. In a competition which requires a final examination of machines before the results are announced, this examination must include a sound control measurement of at least three machines chosen at the discretion of the clerk of the course/FIM race director in co-operation with the chief technical steward. Refer to each discipline for more info.

*"Max. power rpm" values*

Max. power rpm values provided in advance by the vehicle manufacturers, for each specific production vehicle model, and/or measured with the dyno test and/or obtained by specialised magazines, are available upon request ([cti@fim.ch](mailto:cti@fim.ch)).

DIAGRAMS

