

**2022 ENDURANCE TECHNICAL REGULATIONS**



## 2. ENDURANCE TECHNICAL REGULATIONS

Amendments to the Technical Regulations may be made at any time in order to ensure fair competitions.

During practices: If a motorcycle is found not to be in conformity with the **Technical Regulations** during or after the practices, its rider / **team** will be given a penalty for the event such as a **Ride-Through**, a drop of any number of starting grid positions for the race, suspension and/or withdrawal of Championship or Cup points.

After a Race: If a motorcycle is found not to be in conformity with the **Technical Regulations** after a race, its rider / **team** will be given a penalty such as a time penalty, or disqualification.

**In case of a dispute of any of the following technical articles, the decision of the FIM EWC Technical Director / Chief Technical Steward will be final.**

### 2.1 INTRODUCTION

**2.1.1** Motorcycles for the FIM Endurance World Championship with a valid road homologation in one of the following areas: USA, EU or **Asia**.

These motorcycles must be available for sale to the public in the shops and the dealerships representing the manufacturer in at least one of the above areas, before being eligible to participate in the Championship events of the current year.

### 2.2 CLASSES

**2.2.1** The **based-production racing** classes will be designated by engine capacity (EWC, Art. 2.6) and by state of tuning (SUPERSTOCK, Art. 2.7), both with a valid FIM homologation.

The OPEN classes will be designated by engine type and/or technology (EXPERIMENTAL, Art. 2.9).

### 2.3 GENERAL ITEMS

#### 2.3.1 Materials

The use of titanium in the construction of the frame, the front forks, the handlebars **and** the swing arms is forbidden. The use of titanium or aluminium alloys in the construction of swing arm spindles and the wheel spindles is forbidden. Double or 'twin' treaded bolts/spindles are not allowed.

The use of titanium and light alloys for nuts and bolts is allowed.

#### 2.3.3 Handlebars

Exposed handlebar ends must be plugged with a solid material or rubber covered.

The minimum angle of rotation of the handlebar on each side of the centre line or mid position must be of 15° for solo motorcycles.

Whatever the position of the handlebars, the front wheel, tyre and the **front fender** must respect a 10 mm gap.

Solid stops, (other than steering dampers) must be fitted to ensure a minimum clearance of 30 mm between the handlebar with levers and the tank when on full lock to prevent trapping the rider's fingers (see diagrams A, B, C).

The repair by welding of light alloy handlebars is prohibited.

Handlebars made from composite materials are not permitted.

### 2.3.4 Control levers

All handlebar levers (clutch, brake, etc.) must be ball ended (diameter of this ball to be at least 16 mm). This ball can also be flattened, but in any case, the edges must be rounded (minimum thickness of this flattened part 14 mm). These ends must be permanently fixed and form an integral part of the lever (see drawings hereunder).

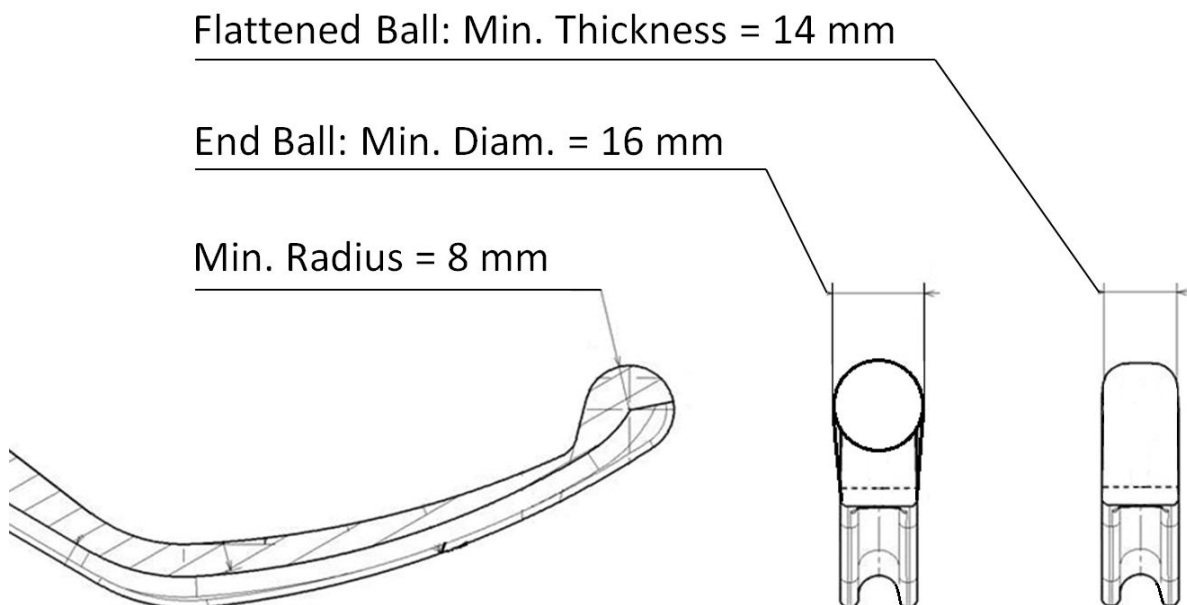

Each control lever (hand and foot levers) must be mounted on an independent pivot.

The front brake lever must be protected by an adapted guard.

The rear brake lever, if pivoted on the footrest axis, must work under all circumstances. If damaged, it must be repaired in working order during the next pitstop.

Modified rider controls will be considered for the mobility challenged subject to a review and approval by the Medical Director. The **FIM EWC** Technical Director's decision on the modifications is final.

### 2.3.5 Wheel & rims (See Table 1)

- 1) All tyres will be measured mounted on the rim at a pressure of 1 kg/cm<sup>2</sup> (14 lb./sq.in.); measurements taken at a tyre section located at 90° from the ground.
- 2) Any modification to the rim or spokes of an integral wheel (cast, moulded, riveted) as supplied by the manufacturer or of a traditional detachable rim other than for spokes, valve or security bolts is prohibited except for tyre retention screws sometimes used to prevent tyre movement relative to the rim. If rim is modified for these purposes bolts, screws etc. must be fitted.
- 3) The wheel rim widths are (in inches):
  - Formula EWC      Front:      3.50"  
                                 Rear:      6.00"  
  
                                 Diameter: 17.00"
  - Superstock      according to the homologated size
- 4) The rim width is the distance between the rim walls measured inside the flange walls in accordance with ETRTO.
- 5) Only wheels made out of the same material as the homologated wheels are permitted, or only for EWC, wheels in aluminium. (See Art. 2.6.6.5 and Art. 2.7.6.5)
- 6) Only steel or aluminium air valves are allowed. Angled tyre air valves are recommended.

### 2.3.6 Tyres

Tyres may be replaced from those fitted to the homologated motorcycle.

**From 01/01/2022 to 31/12/2024 for the FIM Endurance World Cup – Superstock Class:**

**All teams must use the tyres exclusively provided on the circuit of the event by the single supplier contracted for the FIM Endurance World Cup.**

**All “external” tyres not directly supplied by the official representatives of the single supplier on the spot of the event are forbidden.**

**All teams shall respect all the instructions given by the single tyre supplier in how to prepare and use their products (cf. related appendix available the FIM official website: [www.fim.moto.com](http://www.fim.moto.com)).**

#### 1) Requirements

With the exception of slick tyres and tyres marked ‘NOT FOR HIGHWAY USE’ (NHS), the manufacturer must identify the tyre with a mark indicating:

- The DOT mark and/or the E mark (used for "homologated tyres" or tyres marked for highway use only)
- The name of the manufacturer
- The year of manufacture (in code)
- The tyre dimensions
- The speed rating
- Any other features necessary for the correct use of the tyre

## 2) Fitting

- The tyre must be mounted on the correct rim.
- The rim must not be deformed or damaged.

## 3) Permitted minimum speed

The minimum speed rating is: W.

## 4) Tyre surface tread pattern

The tread pattern is unrestricted.

The tread pattern must be made exclusively by the manufacturer when producing the tyre. No handcutting is allowed.

The choice of slick and/or WET weather tyres (and type of tread pattern, where applicable) is left to the discretion of the rider / **team**.

**For the Superstock Class, in case of force majeure and for safety reasons, the single tyre supplier Technical Manager can modify the tyres allocation and the tyres specifications available. In case of such intervention, an official note information from the FIM will be communicated to the teams.**

As a safe minimum, the depth of the tyre tread over the whole pattern at pre-race control must be at least 2.5 mm.

Tyres which at the preliminary examination have a tread depth of less than 1.5 mm are considered as non-treaded tyres and the restrictions applying to slick tyres will then apply to them.

The surface of a slick tyre must contain three or more hollows at 120° intervals or less, indicating the limit of wear on the centre and shoulder areas of the tyre. The rider shall not enter the track if at least 2 of these indicator hollows are worn on different parts of the periphery.

## 5) Tyre control method

1. Tyre restriction for the Formula EWC and Superstock is controlled by FIM tyre stickers. These tyre restriction rules will apply on **all circuits (including every new circuit in the championship, even with new asphalt (resurfaced circuits))**.

2. With the exception of 'full wet' type tyres (drawings of 'full wet' type tyres need to be presented by each tyre manufacturer **before the opening of the season**,

very tyre used during the event must be marked with an adhesive numbered sticker allocated by the FIM Officials.

3. Numbered tyre stickers will be assigned to each team (5 for a 2 riders Team; 7 for a 3 riders Team) in a sealed envelope, the day before the first QP practice. The team **is solely** responsible for the **correct** application **and use of the tyre sticker on the tyre. It is strictly forbidden to apply an “old” tyre sticker given on a previous event or coming from another team.**

4. Both stickers (for the front and the rear tyre) must be applied on the same side of the motorcycle (pit box side). Officials will check that all EWC and Superstock motorcycles in the pit lane are fitted with tyres carrying the sticker. All riders must stop to the “control point” of tyre stickers and wait for the “OK” of the Technical stewards before to rejoin the track. All motorcycles found without tyre sticker(s) will be send back to its pit box by the Officials.

5. The use of motorcycles without the official stickers or a “forcing” of the control point of tyre stickers will be immediately reported to the FIM EWC Stewards Panel who will take appropriate action (see Sporting rules).

6. In exceptional cases, i.e. should the sticker be damaged, up to 1 (one) extra sticker may be provided at the sole discretion of the FIM Technical Director. The damaged sticker and the tyre it was applied to, must be absolutely intact (i.e. not used) and shown to the FIM **EWC** Technical Director. The **FIM EWC** Technical Director may decide to retrieve and hold the tyre in question.

7. A ‘Stop and Go’ penalty may be given for each additional tyre given to a Team.

**8. For the Superstock Class only, for an easy identification, all tyres provided by the single supplier on the circuit of the event will be identified by a special tyre sticker produced and applied by the single supplier itself. This marking from the single supplier is totally independent (and cannot replace at any moment) the tyre control method applied by FIM (through FIM tyre stickers).**

## 6) Tyre sticker quantities

Each Team will be given a fixed number of FIM tyre stickers, assigned to the Team. Each tyre needs to be marked with one sticker, applied carefully to the tyre sidewall (pit box side) (NB: 1 sticker per tyre), before the rider/motorcycle leaves the pit box.

With the exception of **'full wet'** type tyres, all **'slick'** or **'intermediate'** type tyres, used by each Team will be marked with an FIM tyre sticker prior to their use during the Qualifying Practice **s**essions (QP).

1. EWC **c**lass - per Team / (#) = 2 riders Team

- All events: 7 (# 5) tyre stickers for the QP's

2. SUPERSTOCK **c**lass - per Team / (#) = 2 riders Team:

- All events: 7 (# 5) tyre stickers for the QP's

### **3. EWC and SUPERSTOCK classes:**

The 'reserve' rider is not required to use tyres marked with FIM stickers during his QP sessions.

A tyre is considered as 'used' as soon as the rider has left the pitlane with his motorcycle.

The Team is solely responsible for the **correct** application **and use** of the tyre sticker on the tyre.

Any tyre found without this marking will be sanctioned by the FIM EWC Stewards Panel.

#### **2.3.7 Tyre Clearance**

The Team must guard that a minimum safe distance between the surface of the tyre (at its largest point) and any fixed parts of a motorcycle is guaranteed at all time (safe distance = no scrubbing of the tyre against any fixed parts).

#### **2.3.8 Adaptation of the tyre's surface**

In order to obtain optimal tyre adhesion, new unused tyres can be adapted by scuffing the surface. As a safe minimum, the depth of the tyre tread over the whole pattern at pre-race control must be at least 2.5 mm.

#### **2.3.9 Tyre warmers**

The use of tyre warmers is allowed.

#### **2.3.10 Starting devices**

A starting device is compulsory on all motorcycles, regardless of the class entered.

#### **2.3.11 Electrical equipment (lights) and electroluminescent numbers.**

#### **INSTALLATION / PREPARATION:**

All motorcycles must be equipped with a complete electric lighting system with all components in good working order. A complete electrical lighting system means: front and rear lights (no brake lights, no turn signals, no 'flashing' lights).

The following components are part of the electrical lighting system: - headlights, - batteries, - generator, - rear lights and one (1) emergency rear light with the respective cable harnesses.

Whatever the choice of the point 1 or 2 hereunder, the location of the main sources of lighting (main bulb(s)) must be respected as on the homologated motorcycle.

1. The original headlight housing, -(bulbs), the internal parts of headlight(s) and headlight brackets may be modified or replaced. If the optics is glass, it must be

completely covered with an adhesive clear plastic film to prevent it from breaking in the event of an accident.

2. If the original headlamp (s) is / are replaced, the opening or shape of the original headlamp(s) at the front of the fairing must be respected. The original shape and location of the light-housing(s) or each light-housing shall be duplicated with a tolerance of +/- 20mm (as for the shape of headlight plexi/glass cover (as long as the shape of the fairing will not change))).
  3. Each front light source must be a minimum 1200 lumens bulb (or must be in compliance with ECE R112 Class A Headlamp standard). The technical sheet of the factory will prevail.
    - In EWC class the headlights must emit a WHITE light beam (colour temperature equal or upper than 5000K "cold white").
    - For SST and other class(es), the headlights must emit a YELLOW light beam (colour temperature equal or lower than 3000K "yellow / warm white").
  4. A rear light contains a non-flashing red light (lamp/LED,\*).
- \* Each rear light will meet the following specifications: max. 250 lumens, red 630-670 nm recommended; the technical specification sheet will prevail.
5. At least one headlamp and one taillight must be 'ON' at all times during the race (except during the pitstop).
  6. Following a crash or incident, when one front/rear light is broken, this/these must be repaired/replaced during the next pitstop.

When modified, the original or modified wireloom circuit must include:

7. One (1) ON/OFF switch on a wireloom, connected with two (2) head lights, two (2) rear lights, with either single or multiple halogen lights (i.e. xenon, LEDs, OLEDs or LASER).
8. A third, RED rear 'emergency' light\* on a separate wireloom with fuse and an ON/OFF switch, connected to a battery and within reach to be operated by the rider, or an 'autonomous' type with same capacity.  
Either model, the capacity of the battery used must offer 36 hours of lighting. (Li-Po batteries are excluded because they cannot be extinguished). This battery must have the same guarantee of safety as the main battery in terms of attachment to the machine.  
  
\*Each rear light will meet the following specifications: max. 250 lumens, red 630-670 nm recommended; the technical specification sheet will prevail.
9. Magnetic or electronic relays can be used to control each circuit individually.
10. The electroluminescent display of the competitor's number can have its own on / off switches and may be on an independent circuit.

11. Extra identification lights, non-flashing, (no red, yellow or green, max intensity 100 lumens/max. 5 W), may be added, fixed on the streamlining, visible only when viewed from the front and from the side of the motorcycle.

## **OPERATIONS**

All lights (2 headlights and 2 rear lights) must be lit ('on') with the command 'engine start', before the motorcycle is moving and the rider leaves the pit box. When the engine is switched 'off' by the rider, all lights (2 head lights and 2 rear lights) must be switched 'off'.

- The head- and rear lights must be 'off' as the engine is stopped before work and/or refuelling. Only the electroluminescent numbers, the third rear "emergency" red light and the extra identification lights can remain switched on during the pitstop/refuelling.
- If a headlight or rear light is damaged after a crash, the damaged light(s) must be repaired at the next pitstop (**see also: Art.1.7.2 – Lights on**). No motorcycle may leave the pit box with a non-functioning head light or rear light.
- A motorcycle without any lights must exit the track and continue on the service road, on its own power (and at a pace as ordered by Race Direction), by human power or with the recovery vehicle. After a crash during the night, with only an emergency light working, the rider must follow the orders provided by the Race Direction and/or continue on the service road.
- If lights are switched 'on' after the motorcycle has left the pit box/ or are switched 'off' before the motorcycle arrives at the pit box, the team will receive a penalty (ex. a stop-and-go, etc.).

**NOTE:** The electroluminescent numbers and the third rear "emergency" red light shall be working when the panel 'LIGHTS ON' is shown (and during the whole duration of the procedure "LIGHTS ON"). (See also Art. 2.3.12).

Schematic guidelines for lighting installation:

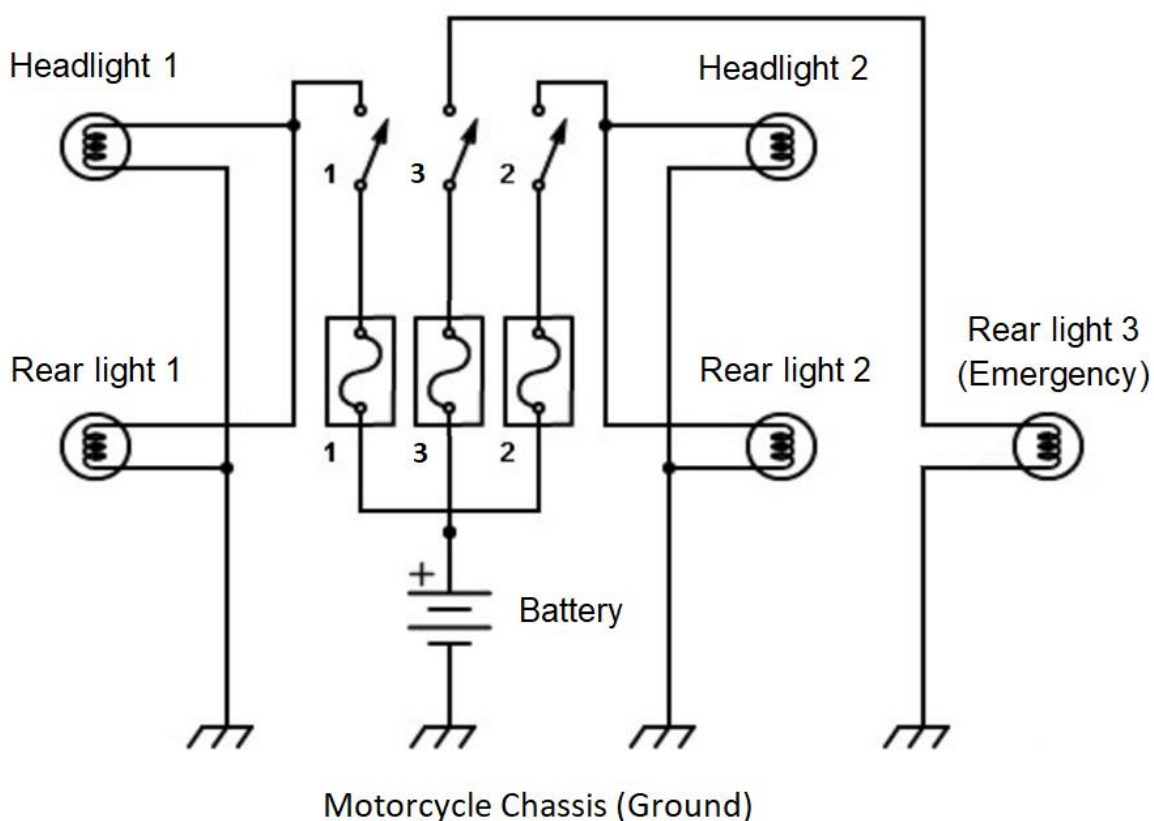

### 2.3.12 Number Plate and Colours

The background colours and figures (numbers) of the number plates are as follows:

Class	Background	Figures
Formula EWC	Black (Ral 9005)	white electroluminescent figures
Superstock	Red (Ral 3020)	white electroluminescent figures
Experimental	Green (Ral 6002)	white electroluminescent figures

The sizes for the numbers are:

- Minimum height (for all front numbers) : 140 mm
- Minimum width (for all front numbers) : 80 mm
- Minimum height (for all side **and rear** numbers) : 120 mm
- Minimum width (for all side and rear numbers) : 70 mm**
- Minimum stroke : 25 mm
- Minimum space between the numbers : 10 mm

The allocated number (& plate) for the rider must be affixed on the motorcycle as follows:

- Once on the front, either in the centre of the fairing or slightly off to one side. The top of the figures must be inclined towards the centerline. The number must be centered on the background with no advertising within 25mm in all directions.
- Once, on each sides of the motorcycle. Alternatively, once across the top of the rear seat section with the top of the number towards the rider. The number must be centered on the background.

For light coloured bodywork, there shall be a black line of 8 mm minimum all around the perimeter of the background.

### **2.3.13 Reflective area**

Only for races taking place partly at night, a red reflective surface with minimum area of 60 cm<sup>2</sup> must be fixed onto the rear of the motorcycle seat cowling and must remain entirely visible by following riders.

### **2.3.14 Handprotectors**

Only in rain conditions and/or low ambient temperatures, additional hand-protectors may be attached to the streamlining with "quick-fit" type fasteners. Hand-protectors are intended to give extra protection to the hands only and cannot exceed the handlebar width. All sharp edges must be rounded. The required clearances between handlebars, clutch and brake lever/-protectors and these hand-protectors must be respected when these are fitted to the streamlining (see Diagram A-3). **These handprotectors cannot have any aerodynamic purpose and be used as such.**

Handprotectors must be presented and validated by the FIM **EWC** Technical Director before their installation and use. **The usage will be authorized by the FIM EWC Technical Director according to the weather conditions.**

### **2.3.15 Refuelling**

**Until 31/12/2022**, the following articles apply :

The original fuel tank cap must be replaced by maximum two openings to accommodate a 'quick-fill' type (i.e. aviation type) fuel valve and must provide a closed system. Quick fill valves with concentric openings are permitted.

1. The original fuel tank cap must be replaced by one (1) or two (2) openings to accommodate a 'quick-fill' type (i.e. aviation type) fuel valve.

Coaxial or side-by-side quick fill type valve systems are permitted.

Whatever the system chosen by the team, the maximum internal diameter (ID) for the opening of the fuel transfer shall not exceed 2 inches (50.8mm).

- In case a Team uses a side-by-side quick fill fuel valve system (with an ID opening larger than 2 inches), the Team will be required to install a restrictor (with an Internal constant Diameter of 2 inches (50.8mm) maximum on a minimum height of 110mm (as shown on the following drawing)) in the fuel supply line directly positioned above the fuel valve to balance the fuel flow. Both ends of the cylinder shaped restrictor shall be cut at an angle of 90°.

ID = Internal Diameter

H = Height

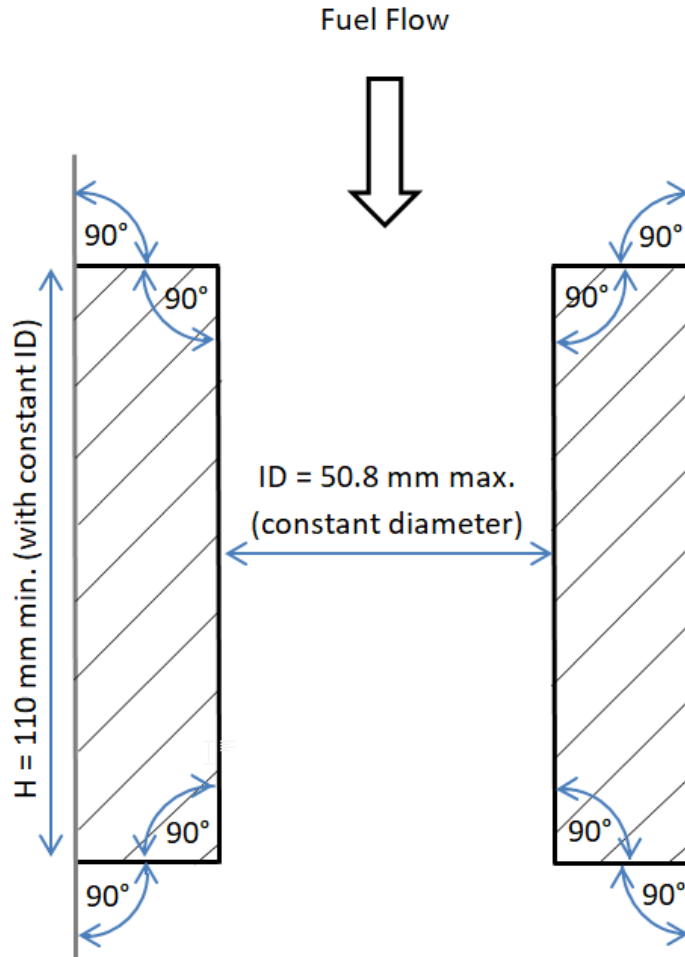

- A protective and lockable cover must be affixed on the quick-fill fuel valve(s) if no locking device is already applied to the closing system within the receptive part of the quick fill fuel valve installed in the motorcycle fuel tank.

- Any tampering with the opening or closing of the quick fuel valve system installed in the fuel tank will be considered as an infringement to the safety requirement.

- The action of opening and closing of the valves when fuel and air are transferred must take place without any leaks or fuel spillage.

**2.** Complete refuelling systems must be used either in the form of a 'portable' fuel container or as a 'fuel tower' installation fixed securely to the pit box wall.

- Each system must have a 'closed' and leak proof circuit for the transfer of fuel.
- Each system must be fitted with a ventilation opening to equalise the pressure within the circuit with the ambient air pressure.
- Fuel shall only be transferred by gravity feed. For safety reasons, no part of the refuelling installation may be cooled or pressurized.

- The top of the tower-installed fuel container shall not exceed a maximum height of 2.60m (measured from the ground).
- Fuel type supply hoses must be reinforced or be protected by a second outer layer (or larger tube). The maximum internal diameter (ID) for fuel supply hoses tubes shall not exceed 60mm.
- The maximum dimension (length/height) of the portable fuel container is 100cm. In any case, the total length/height of a portable container and quick fill fuel valve assembly shall not exceed 120 cm.
- Cameras or any other electrical equipment (batteries or power supply sources) cannot be mounted/affixed to this portable fuel container.
- Excess fuel must return to the fuel container tower or to a handheld container. Extremely thin walled hoses used for air transfer cannot be used for fuel supply or overflow. In the event that a safety issue was reported, the decision by the FIM **EWC** Technical Director to accept/refuse said installation will be final.
- All fuel shall be stored and used at ambient temperature.

**3.** Fuel spills are not acceptable and very dangerous. Fuel transfer is not without any risks. Every team must be extremely careful and attentive when handling fuel during fuel stops. Any evidence of a defective system observed or reported will be sanctioned. The Team must follow all directives given by the Officials and/or by the Firefighters.

**4.** All personnel who are involved in the refuelling operations, including the person responsible for the fire extinguisher, must wear an overall made of fire retardant materials; hands and feet must be protected with gloves and footwear made of fire retardant materials; safety goggles and mask and a balaclava of fire-retardant quality. The use of a suitable protective helmet and eye protection is compulsory. **The original labels sewn by the manufacturer on all these fire-retardant material products must be present and readable by the FIM/FMN technical crew during the scrutineering in order to check the conformity of the fire-retardant material.**

**All refuelling or “draining” interventions must be secured by a firefighter ready to intervene with an extinguisher in case of issue.**

**From 01/01/2023 to 31/12/2031 (2 periods of 5 years (2022: transition year)-2026 and 2027-2031):**

**All teams will have to use the complete FIM Homologated Fuel Quick Fill System (parts list detailed hereunder).**

**FIM EWC Parts list - 8000115196F (or latest update) downloadable on the FIM official website [www.fim-moto.com](http://www.fim-moto.com).**

**No modification of any parts of the original homologated system (presented in the parts list here above) is allowed.**

**However, for the teams wishing to develop a “support” system to help the refueller in the holding/handling of the portable container, such system may be**

authorized (without any modification of the original homologated system) and must be validated by the FIM EWC Technical Director in prior of its use.

All teams must use the same specification as described in the latest parts list. The list of the Homologated Parts (including older tank plug for example) is downloadable on the FIM official website [www.fim-moto.com](http://www.fim-moto.com).

Fuel shall only be transferred by gravity feed. For safety reasons, no part of the refuelling installation may be cooled or pressurized.

Cameras or any other electrical equipment (batteries or power supply sources) cannot be mounted / affixed to this portable fuel container.

After the refuelling intervention is done and the motorcycle left the front of the pitbox, the excess of fuel present in the venting line must systematically be drained into the fuel drain container through the FIM Homologated air drop valve (refer to FIM EWC Parts list - 8000115196F (or latest update)). The air drop valve implantation plan is available on the parts List.

The main body of the drain container is free of design but must be in metal (Aluminium) and sized to be able to contained all the fuel remaining in the venting line (2 liters minimum).

After the venting line is drained, the main portable container can be filled (special procedure for Le Mans will be explained in Supplementary Regulations). That is the only moment when the team is authorized to remove the top cap (including the non-spill valve) present on the container. As soon as the container is filled, this top cap must be fitted back on the container to get the system leak-proof again. All refuelling or “draining” interventions must be secured by a firefighter ready to intervene with an extinguisher in case of issue.

All fuel shall be stored and used at ambient temperature.

3. Fuel spills are not acceptable and very dangerous. Fuel transfer is not without any risks. Every team must be extremely careful and attentive when handling fuel during fuel stops. Any evidence of a defective system observed or reported will be investigated and can be sanctioned at a later stage in case of evidence of modification by the team after investigation. The team must follow all directives given by the Officials and/or by the firefighters.

4. All personnel who are involved in the refuelling operations, including the person responsible for the fire extinguisher, must wear an overall made of fire-retardant materials; hands and feet must be protected with gloves and footwear made of fire-retardant materials; safety goggles and mask and a balaclava of fire-retardant quality. The use of a suitable protective helmet and eye protection is compulsory. The original labels sewn by the manufacturer on all these fire-retardant material products must be present and readable by the FIM/FMN technical crew during the scrutineering in order to check the conformity of the fire-retardant material.

5. Before and after the refuelling intervention, the PLUG CAP (P/N 100041568 or latest part reference) can be handled either:

- by the rider (leaving the motorcycle) to take off the plug cap.
- by the rider (taking the motorcycle) to put back the plug cap.
- by the person appointed as assistant refueller (equipped as the refueller (4.))
- by one of the 4 identified mechanic (equipped as the refueller (4.))

**The PLUG CAP (P/N 100041568 or latest part reference) must be back in place to release the motorcycle in the pitlane. In case this part is lost during a session or stint, the team will have to reup a new one after the next pitstop.**

### **2.3.16 Markings**

The frame and engine (crankcase(s)) must be marked and/or sealed before the practice sessions and before the race. At the discretion of the FIM **EWC** Technical Director, these numbers may be verified after the qualifying practice sessions and after the race.

During the race, all defective parts may be replaced with the exception of the frame and crankcases.

### **2.3.17 Ballast**

The use of ballast is allowed to stay over the minimum weight limit. The use of ballast must be declared to the FIM **EWC** Technical Director/Chief Technical Steward at the **scrutineering** and before the race. Nevertheless, the verified weight may never fall below the required minimum weight required for each Class.

All ballast must be made from solid metallic piece/s, firmly, securely connected, either through an adapter or directly to the main frame or engine, with minimum 2 steel bolts (min. 8 mm diameter, 8.8 grade or over). Other equivalent technical solutions must be submitted to the FIM **EWC** Technical Director for his approval.

### **2.3.18 Timekeeping Instruments**

All motorcycles must have a correctly positioned timekeeping transponder. The transponder must be supplied or approved by the official Timekeeper and fixed to the motorcycle in the longitudinal centre of the motorcycle (typically close the swing-arm pivot), on the right side, as low as possible and avoiding being shielded by carbon bodywork.

Correct attachment of the transponder bracket consists of a minimum of tie-wraps, but preferably by screws or rivets. Any transponder retaining clip must also be secured by a tie-wrap. Velcro or adhesive alone will not be accepted. The transponder must be working at all times during practices and races, also when the engine is switched off.

## 2.6 FORMULA EWC TECHNICAL SPECIFICATIONS

### EVERYTHING THAT IS NOT PRESCRIBED OR SPECIFICALLY ALLOWED IN THESE REGULATIONS IS STRICTLY FORBIDDEN

Formula EWC motorcycles are based on road legal models with a valid FIM homologation.

Formula EWC motorcycles require a FIM “Superbike” Homologation. The homologated “Superbike” model must not exceed a maximum retail price of 40.000 Euros (incl. taxes).

(The FIM Homologation procedure is available on [www.fim-moto.com](http://www.fim-moto.com) in the “Documents” section on the main page).

All motorcycles entered in the Formula EWC class must comply in every respect with all the requirements for Circuit Racing as specified in these Technical Regulations, unless they are already equipped as such on the homologated model.

The appearance from both front, rear and the profile of Formula EWC motorcycles for Endurance must (except when otherwise stated) conform in principle to the homologated shape (as originally produced by the manufacturer). The appearance of the exhaust system is excluded from this rule; the silencer(s) must remain on the same side as homologated on the original model.

#### 2.6.1 Displacement capacities

Over 600cc up to 1000cc	4-stroke	4 cylinders
Over 750cc up to 1000cc	4-stroke	3 cylinders
Over 850cc up to 1200cc	4-stroke	2 cylinders

The displacement capacity **and** bore and stroke must remain at the homologated size.

#### 2.6.2 Minimum weight

All machines: 168 kg for all races.

This is the absolute minimum weight (without the fuel tank and its content).

(“Its content” includes: fuel onboard, all fuel tank internal parts, fuel valve(s) system (+ protective cover (if any)), fuel pump, glued protective covers/rider anti-slip systems).

At any time during the event, the weight of the whole motorcycle (excluding the fuel tank and its content) must not be less than the minimum weight.

There is no tolerance on the minimum weight of the motorcycle.

The use of ballast is allowed to stay over the minimum weight limit and may be required due to a handicap system. The use of ballast and weight handicap must be declared to the FIM **EWC** Technical Director / Chief Technical Steward at the preliminary checks and/or prior to the race.

During the practice and qualifying sessions, riders may be asked to submit their motorcycle to a weight control in the pit lane. The minimum weight during the QPs remains at 175 kg (including the fuel tank and its content).

In all cases the rider (and the team) must comply with this request for a control. Any “forcing” of the control point of the weight control will be immediately reported to the FIM EWC Stewards Panel who will take appropriate actions (see Sporting rules).

During the **F**inal **T**echnical **I**nspection at the end of each race, the selected motorcycles will be weighed in the condition they finished the race (without the fuel tank and its content), and the established weight limit must be met in this condition. Nothing may be added to the motorcycle. This includes all fluids.

The minimum weight includes all Championship contracted devices whether fitted or not, such as **t**ransponder and on-board TV system.

#### **2.6.4 Fuel injection system (Injection and throttle bodies)**

Fuel injection system (refers to the complete system, including throttle bodies and variable length intake tract devices) must remain as homologated. No modifications are allowed. See also art 2.6.6.18.

#### **2.6.5 Fuel**

**All teams must use the fuel provided by the appointed single fuel supplier contracted for the FIM Endurance World Championship/Cup if any (except for Le Mans).**

All motorcycle engines must function on normal unleaded fuel with a maximum lead content of 0.005 g/l (unleaded) and a maximum MON of 90 (see also Art. 2.10 for fuel specifications).

#### **2.6.6 Motorcycle specifications**

All items not mentioned in the following articles must remain as originally produced by the manufacturers for the homologated motorcycle.

##### **2.6.6.1 Main frame body and rear subframe**

The main frame must be the originally manufactured part produced and fitted by the manufacturer and be used on all the units produced following the homologated motorcycle model.

The main frame must have a **V**ehicle **I**dentification **N**umber (VIN), as issued by the manufacturer on the homologated model. Any main frame (as ‘original’ or originating as ‘spare part’) must be identical to the original homologated part, and correspond to all the dimensions on the drawings. Such main frame must be identified by permanent method by a special and unique number. (Example: “YEAR - TEAM - 01”)

The main frame may only be modified by the addition of gussets or tubes. No gussets or tubes may be removed, other modifications are allowed within the following section of these rules:

Holes may be drilled on the frame only to fix authorised components (i.e. fairing brackets, steering damper mount, frame protectors).

The dimensions and position of:

- Engine
- Suspension linkage mounting points on the frame must remain as homologated.

Steering angle changes are permitted by fitting inserts onto the bearing seats of the original steering head pipe. The original bearing seat diameters on steering head pipe may be increased to insert special bushings. The new fore and aft position of each bearing can be a maximum +/- 6 mm in respect to the original bearing location.

No part of these special bushings may protrude axially more than 3 mm from the original steering head pipe location. The steering head pipe can be reinforced in the area of the bearing seats. Welding and machining is allowed for the purpose of making these modifications.

Modifications to the frame at the swing arm pivot area are allowed to give a maximum of +/-5 mm of adjustment in the radial view. Welding and machining is allowed for the purpose of making this modification of the original swing arm pivot, regardless of the technology used and the dimensions of the component or section of the frame (i.e: cast, fabricated, etc.).

Protective covers made from composite materials protecting a section of a frame are permitted and must be attached securely. Adequate space must be available to affix the FIM Technical Verification sticker (on a smooth surface).

The homologated rear subframe construction may be modified, but the design, purpose and assembly must remain as used by the homologated part. The material used must remain as homologated or of higher specific weight.

The material for the seat pad may be modified and/or replaced.

The material of the streamlining/seat section may be replaced, but the homologated shape/profile must remain as homologated.

The paint scheme is not restricted.

### **2.6.6.2 Front fork**

Front fork in whole or part may be changed but must be the same type homologated (leading link, telescopic, upside down, etc.). A small support for the front wheel stand may be added (round or flat, in steel, aluminium, with max. dimensions for length x height (starting horizontally from the center of the front axle shaft: maximum dimensions: 80 mm x 110 mm) with a minimum thickness of this part of 6 mm. All edges must be rounded and face inwards.

No aftermarket or prototype electronically-controlled suspensions may be used.

An electronically-controlled suspension may only be used if already present on the production model of the homologated motorcycle.

The electronically-controlled valves must remain as homologated. The shims, spacers and fork springs not connected with these valves can be changed.

The ECU for the electronic suspension must remain as homologated.

The electronic interface between the rider and the suspension must remain as on the homologated motorcycle. It is allowed to remove or disable this rider interface.

The original suspension system must work safely in the event of an electronic failure.

Electro-magnetic fluid systems which change the viscosity of the suspension fluid(s) during operation are not permitted.

The upper and lower fork clamps (triple clamp, fork bridges) can be changed or modified.

Steering damper may be added or replaced with an after-market damper.

The steering damper cannot act as a steering lock limiting device.

Electronic controlled steering damper cannot be used if not installed in the homologated model for road use. However, it must be completely standard (any mechanical or electronic part must remain as homologated).

### **2.6.6.3 Swingarm**

The rear swingarm may be altered or replaced from those fitted to the homologated motorcycle. However, the type single or double sided must remain as homologated. The use of carbon fibre or Kevlar® materials is not allowed if not homologated on the original motorcycle.

Protective covers made from composite materials to protect a section of a swingarm are permitted and must be attached securely.

A chain guard must be fitted to the swing-arm in such a way to reduce the possibility that any part of the riders' body should become trapped between the lower chain run and the rear wheel sprocket. This lower chain guard (a.k.a. shark-fin) must cover substantially the opening where the chain meets the rear sprocket. Chain guards must be made of strong material (steel, aluminium, composites) and face inwards.

Rear wheel stand brackets may be added to the rear swingarm by welding and/or attached by bolts.

These brackets (in steel or aluminium, fitted behind or below the swingarm) must respect maximum dimensions (measured all around the swingarm) for length x height: 120 mm x 120 mm) with a minimum thickness of this part of 6 mm. All edges must be rounded and face inwards.

Fastening screws must be recessed. A small bracket to retain the chain (steel, aluminium) is permitted, securely mounted, edges must be rounded. Max dimensions: length: 40 mm; height above the swingarm: 40 mm; width/thickness: 10 mm).

#### **2.6.6.4 Rear suspension unit**

Rear suspension unit can be changed but a similar system must be used (i.e. dual or mono).

Electronically-controlled suspension may only be used if already present on the production model of the homologated motorcycle.

The electronically-controlled valves must remain as homologated. The shims, spacers and shock absorber springs not connected with these valves can be changed.

The ECU for the electronic suspension must remain as homologated.

The electronic interface between the rider and the suspension must remain as on the homologated motorcycle. It is allowed to remove or disable this rider interface.

The original electronic system must work safely in the event of an electronic failure.

Electro magnetic fluid systems which change the viscosity of the suspension fluid(s) during operation are not permitted.

The rear suspension linkage may be modified or replaced

The original fixing points in the frame (if any) must be used to mount the shock absorber, linkage and rod assembly fulcrum (pivot points).

#### **2.6.6.5 Wheels**

Wheels (see Art. 2.3.5.2), and associated parts may be altered or replaced from those fitted to the homologated motorcycle.

Magnesium (unless homologated), carbon or carbon composite wheels are not allowed, unless the manufacturer has equipped the homologated production model with this type of wheel.

Bearings, seals, spacers and axles may be altered or replaced from those fitted to the homologated motorcycle. The use of titanium and light alloys is forbidden for wheel spindles (axles).

Wheel balance weights may be discarded, changed or added to.

Any inner tube (if fitted) or inflation valves may be used.

Diameter for front and rear wheel rims:	17.00 inches
Front wheel rim width:	3.50 inches
Rear wheel rim width:	6.00 inches

#### **2.6.6.6 Brakes**

Front master cylinder may be altered or replaced from those fitted to the homologated motorcycle.

Front brake calipers may be altered or replaced from those fitted to the homologated motorcycle.

Front brake system cooling airducts are allowed. This duct (1) must be fitted between the front brake caliper and the front brake caliper bracket. No modifications to the front brake calipers are allowed.

Air ducts shall be routed to cool the discs or directed onto the brake caliper bodies. Viewed from the side, the airducts opening shall not pass the vertical line drawn by the front axle shaft. Viewed from the front, the airducts must fall inside the shape drawn by the fairing (aerodynamic winglets excluded) and must be positioned as close as possible to the front fork leg/foot. For safety reasons, the airflow shall not be directed onto the brake pads.

The air-ducts may be made of composite materials. The complete assembly must be presented and validated by the FIM **EWC** Technical Director in prior of its use.

Rear master cylinder may be altered or replaced from those fitted to the homologated motorcycle.

Rear brake calipers may be altered or replaced from those fitted to the homologated motorcycle.

Brake pads may be altered or replaced from those fitted to the homologated motorcycle.

Brake hoses and brake couplings may be altered or replaced from those fitted to the homologated motorcycle. The split of the front brake lines for both front brake calipers must be made above the lower fork bridge (lower triple clamp). Brake line hose fittings (including banjo bolts) can only be **steel** or **titanium**. Quick couplings can remain in **aluminium**.

Brake discs may be altered or replaced from those fitted to the homologated motorcycle. Only ferrous materials are allowed for brake discs. The use of exotic alloy materials for discs and brake calipers (i.e. aluminium beryllium, etc.) is not allowed.

The Antilock Brake System (ABS) may be used only if installed in the homologated model for road use. The type of system (mechanical or electronic) and the ABS pump/pressure regulator must remain as homologated on the the homologated motorcycle. Discs, speed sensor (rotor), brake calipers, master cylinder and the software of the ABS may be modified or replaced. Only ferrous materials are allowed for brake discs. The use of exotic alloy materials for brake calipers (i.e. aluminium-beryllium, etc.) is not allowed.

The Anti Lock Brake system (ABS) can be disconnected and the ABS pump/pressure regulator can be removed.

#### **2.6.6.7 Tyres**

See Art. 2.3.6.

### **2.6.6.8 Handle bars and hand controls**

Only one (1) RED engine stop switch may be located on the left or right handle bar, **reachable from the rider with the rider's hand on the grip.**

Throttle controls must be self closing when not held by the hand.

Handlebars, hand controls and associated cables may be altered or replaced from those fitted to the homologated motorcycle (see Art. 2.3.4), but all hand controls, electric starter switch and engine stop switch must remain on the handlebars. Other switches may be changed.

Clutch and brake lever may be replaced with an aftermarket model (see also Art. 2.3.4).

It is compulsory to equip all motorcycles with a solid brake lever guard preventing the brake lever from being accidentally activated in case of collision with another motorcycle.

### **2.6.6.9 Foot rest / foot controls**

Foot rest/foot controls may be relocated, but the original mounting points must be used.

Foot rests may be rigidly mounted or a folding type which must incorporate a device to return them to the normal position.

The end of the foot rest must have at least an 8mm solid spherical radius. (see diagram A & C).

Non-folding footrests must have an end (plug) which is permanently fixed, made of aluminium, plastic, Teflon® or equivalent type of material (min. radius of 8mm). The plug surface must be designed to reach the widest possible area of the footrest. The FIM **EWC** Technical Director / Chief Technical Steward has the right to refuse any plug not satisfying this safety aim.

### **2.6.6.10 Fuel tank**

The original fuel tank may be modified or replaced with a copy to achieve the maximum capacity of 24 litres, provided that the homologated appearance and location are maintained. However, the actual shape of the tank can be slightly changed to suit the rider's preference.

**All fuel tanks must be filled with fire retardant material (open-celled mesh, i.e. "Explosafe®, ExploStop®").**

The fuel tank used during practice must be of the same size (max. capacity 24L) and be fitted with the same type quick fill fuel valve system during the entire event.

The fuel tank may be modified below the upper frame line. The extended part of the fuel tank shall remain protected by the seat sub-frame (in case of crash). Its underside must also be shielded by a protective cover. Whatever the position of the rear wheel, it shall not touch this protective cover of the extended fuel tank (minimum clearance

between the wheel and the protective cover: 10mm). The modified fuel tank shall not extend past a vertical line drawn through the rear wheel axle.

The material used in the construction of the fuel tank may be altered from the material used of the original fuel tank fitted on the homologated motorcycle. Other than steel, only aluminium must be used in the construction of the fuel tank. The minimum wall thickness must be of 1.2 mm.

Carbon or aramid fibres or fibreglass materials are not authorised in the construction of fuel tanks.

Protective tank covers **must** be fitted on the exposed edges (**in case of crash**) of tanks made of steel. **These protectors must fit the shape of the fuel tank.** These covers must **be** presented and the application validated by the FIM **EWC** Technical Director (from 01/01/2022).

The fuel tank must be fixed to the frame from the front and the rear with a crash-proof assembly system, with a minimum of 3 bolts of 5mm diameter (or more). Bayonet style couplings can not be used, nor any fixing to any parts of the streamlining. The FIM **EWC** Technical Director / Chief Technical Steward have the right to refuse a motorcycle if he is of the opinion that the fuel tank fixation method is not safe.

Fuel tanks with tank breather pipes must be fitted with non-return valves which discharge into a catch tank with a minimum volume of 250cc **and a maximum volume of 350cc** made of a suitable material.

**Until 31/12/2022:** The fuel tank filler cap must be of a 'quick-fill' type and when closed, must be leak proof. Any tampering to the opening or closing of the quick fuel valve system of the fuel tank will considered as an infraction to the safety requirement (leak proof). Additionally, the system must be secured to prevent accidental opening at any time (See also Art. 2.3.15).

**From 01/01/2023 to 31/12/2031 (2 periods of 5 years (2022: transition year)-2026 and 2027-2031):**

**The original fuel tank cap must be replaced by the following FIM Homologated Fuel Quick Fill system (parts list detailed hereunder):**

**FIM EWC Parts list - 8000115196F (or latest update) downloadable on the FIM official website [www.fim-moto.com](http://www.fim-moto.com).**

**No modification of any parts of the original homologated system (presented in the parts list here above) is allowed.**

**All teams must use the same specification as described in the latest parts list. The list of the Homologated Parts (including older tank plug for example) is downloadable on the FIM official website [www.fim-moto.com](http://www.fim-moto.com).**

**The PLUG CAP (P/N 100041568 or latest part reference) must be back in place to release the motorcycle in the pitlane. In case this part is lost during a session or stint, the team will have to reup a new one after the next pitstop.**

### 2.6.6.11 Fairing / body work

- a) Fairing and body work must conform in principle to the homologated shape as originally produced by the manufacturer.
- b) Wind screen may be replaced.
- c) Original air ducts running between the fairing to the airbox may be altered or replaced from those fitted to the homologated motorcycle.
- d) The lower fairing has to be constructed to hold, in case of an engine breakdown, at least half of the total oil and engine coolant capacity used in the engine (min. 5 litres). The lower edge of openings in the fairing must be positioned at least 50 mm above the bottom of the fairing.

The lower fairing section must remain leak proof at all times. (A hole of 25 mm is no longer required). The rear of the lower fairing must be fixed by a minimum of two brackets **or bolts** to the engine or to the frame to carry the lower fairing when filled with liquid.

- e) Minimal changes are allowed in the fairing to permit the use of an elevator (stand) for wheel changes and to add plastic protective cones to the frame or the engine.
- f) Holes may be drilled or cut in the fairing or bodywork to allow additional increased intake air to the oil cooler. Holes bigger than 10mm must be covered with metal gauze or fine mesh. Mesh must be painted to match the surrounding material. Original openings for cooling in the lateral fairing/bodywork sections may be partially closed only to accommodate sponsors' logos/lettering. Such modification shall be made using wire mesh or perforated plate ('the material is free but the distance between all opening centres, circle centres and their diameters must be constant'). Holes or perforations must have an open area ratio > 60%.
- g) A front fender must be fitted. Material, shape, fixing method and position may be altered or replaced from those fitted to the homologated motorcycle.
- h) Holes may be drilled in the front **fender** to allow additional cooling. Holes bigger than 10mm must be covered with metal gauze or fine mesh. Mesh must be painted to match the surrounding material.
- i) Rear fender may be altered, added or removed.
- j) Material of construction for the fairing and the **front + rear fenders** may be changed.
- k) Additional heatshield may be installed on the rear exhaust pipe section and running up and inside the rider's footrest. This heatshield **cannot have any aerodynamic purpose and be used as such**. The appreciation of this piece remains a decision of the FIM **EWC** Technical Director.

### 2.6.6.12 Seat

**The seat** may be altered or replaced from those fitted to the homologated motorcycle.

The top portion of the rear body work around the seat may be modified to a solo seat. The solo seat then must incorporate the rear number plates. The appearance from both front rear and profile must conform in principle to the homologated shape.

The seat/rear cowl must allow for proper number display.

Holes may be drilled in the seat or rear cowl to allow additional cooling. Holes bigger than 10 mm, must be covered with metal gauze or fine mesh. Mesh must be painted to match the surrounding material.

Material of construction of the seat may be altered or replaced from those fitted to the homologated motorcycle.

#### **2.6.6.13 Radiator, cooling system and oil cooler**

The original radiator or oil cooler may be altered or replaced from those fitted to the homologated motorcycle.

Additional radiators or oil coolers may be added. The oil cooler shall not be mounted on or above the rear **fender**.

The radiator tubes may be changed.

Radiator fan and wiring maybe removed or replaced.

The appearance from the front, rear and profile of the motorcycle must in principle conform to the homologated shape after the addition of additional radiators or oil coolers.

Thermal switches, water temperature sensor and thermostat can be removed inside the cooling system.

#### **2.6.6.14 Electric and electronic devices**

Electric cables, connectors, and switches are free.

#### **2.6.6.15 Battery**

The battery may be replaced.

**For safety reasons, whatever is the technology of the battery used, no charging is allowed without any surveillance and during the night (in the pitbox or in the team' truck). The charging area must be safe as possible and as far away as possible of any fuel cans.**

#### **2.6.6.16 Airbox**

The air box must remain as originally produced by the manufacturer on homologated motorcycle but the air box drains must be sealed. The air box cover, when housing the standard ECU, may be modified to fit an after-market/kit ECU, without increasing the original airbox volume.

Air filters, internal flap type valve, sensors and vacuum fittings may be removed, modified, or replaced with aftermarket parts. The air filter element may be modified or replaced.

Any holes in the air box to the outside atmosphere resulting from the removal of components must be completely sealed from incoming air.

Ram air tubes or ducts running from the fairing to the air box may be modified, replaced or removed. If tubes/ducts are utilized, they must be attached to the original, unmodified air box inlets.

All motorcycles must have a closed breather system. All the oil breather lines must be connected and discharge in the air box.

#### **2.6.6.18 Fuel injection system / throttle bodies**

Fuel injection systems refer to throttle bodies, fuel injectors, variable length intake tract devices, fuel pump and fuel pressure regulator.

The original homologated fuel injection system must be used without any modification.

The fuel injectors must be stock and unaltered from the original specification and manufacture.

Bell mouths, intake tract devices (velocity stacks, air funnels) may be modified or replaced, including their fixing points.

Variable intake tract devices cannot be added if they are not present on the homologated motorcycle. If present on the homologated motorcycle, variable intake tract devices must remain identical and operate in the same way as the homologated system.

Air and air/fuel mixture can go to the combustion chamber exclusively through the throttle body butterflies.

Electronically controlled throttle valves, known as 'ride-by-wire', may be only used if the homologated model is equipped with the same system. Software may be modified but all the safety systems and procedures designed by the original manufacturer must be maintained.

The fuel injection management computer chip (EPROM) may be changed.

The use of flash memory (flash RAM) for fuel injection mapping is allowed.

#### **2.6.6.19 Fuel supply**

Fuel pump and pressure regulator **cannot** be modified.

The original fuel valve (petcock) may be altered, replaced or removed from those installed on the homologated motorcycle.

Quick connectors or dry break quick connectors may be used.

Fuel lines from the fuel tank up to the injectors (fuel hoses, delivery pipe assembly, joints, clamps, fuel canister) may be replaced, without increasing the fuel volume.

The fuel line(s) going from the fuel tank to the fuel injection instruments must be located in such a way that they are protected from possible crash damage.

A cross over line between each side of the tank is allowed (maximum inside diameter 10 mm).

Fuel vent lines may be replaced.

Fuel filters may be added.

#### **2.6.6.20 Cylinder head**

The homologated cylinder head may be modified as follows:

Homologated materials and castings for the cylinder heads must be used. Material for these parts may only be removed by machining.

The induction and exhaust system including the number of valves and or ports (intake and exhaust) must be as homologated.

Porting and polishing of the cylinder head normally associated with individual tuning such as gas flowing of the cylinder head, including the combustion chamber is authorised.

The compression ratio is free.

Valves must remain as homologated.

Valve seats must remain as homologated. Only normal maintenance interventions as prescribed by the manufacturer in the model's Service Manual are authorized.

Valve guides must remain as homologated. Modifications to the port area are allowed.

Valve springs may be altered or replaced from those fitted to the homologated motorcycle. The material must remain as homologated.

Valve spring seats and retainers may be altered or replaced from those fitted to the homologated motorcycle. The material of the valve spring seat must remain as homologated.

Cotter valves may be altered or replaced from those fitted to the homologated motorcycle.

The cylinder head cover must remain as homologated.

#### **2.6.6.21 Camshaft**

Camshafts may be **modified** or replaced from those fitted to the homologated motorcycle but the material and the method of fabrication and the drive method must remain the same as homologated. Cam profile dimensions are free.

The type of cam chain or cam belt is free. The cam chain or cam belt tensioning device(s) may be modified or replaced.

Offsetting the camshaft (from its homologated position in the cylinder head) is not allowed. The camshaft must remain in the homologated location.

#### **2.6.6.22 Cam sprockets**

Cam sprockets or cam gears may be **modified** or replaced to allow the degreeing of the camshafts.

#### **2.6.6.23 Crankshaft**

No modifications are allowed (including polishing and lightening).

The balance shaft must remain as homologated.

#### **2.6.6.24 Oil pumps and oil lines**

No pump modifications are allowed.

Oil lines may be modified or replaced. Oil lines containing positive pressure, if replaced, must be of metal reinforced construction with swaged or threaded connectors.

#### **2.6.6.25 Connecting rods**

No modifications are allowed (including polishing and lightening).

- a. The connecting rod must be the originally fitted and homologated part with no modification allowed.
- b. Connecting rod big end nuts/bolts may be changed but must be of the same weight or heavier, same material or of higher specific weight material.
- c. The weight of the connecting rod assembly is the homologated weight (normally the weight of the middle weight rod) with a tolerance of +/-3%.

#### **2.6.6.26 Pistons**

No modifications are allowed (including polishing and lightening).

#### **2.6.6.27 Piston rings**

No modifications are allowed.

#### **2.6.6.28 Piston pins and clips**

No modifications are allowed.

#### **2.6.6.29 Cylinders**

No modifications are allowed.

### **2.6.6.30 Crankcase, other engine cases and covers (i.e. ignition case cover, clutch case cover.)**

Crankcases must remain as homologated. No modifications to the crankcases are allowed (including painting, polishing and lightening).

The oil sump may be altered or replaced.

It is not allowed to add a pump used to create a vacuum in the crankcase. If a vacuum pump is installed on the homologated motorcycle then it must be used only as homologated.

Lateral (side) covers may be altered, modified or replaced. If altered or modified, the cover must have at least the same resistance to impact as the original one. If replaced, the cover must be made in material of same or higher specific weight and the total weight of the cover must not be lower than the original weight.

All lateral covers/engine cases containing oil and which could be in contact with the ground during a crash, must be protected by a second cover made from metal, such as aluminium alloy, stainless steel or steel.

Plates or crash bars made from aluminium or steel also are permitted in addition to these covers. All of these devices must be designed to be resistant against sudden shocks, abrasions and crash damage.

FIM protective covers declared eligible for competition will be permitted without regard of the material.

These covers must be fixed properly and securely with case cover screws (minimum 3 fixing points) that also mount the original covers/engine cases to the crankcases.

The **FIM EWC** Technical Director has the right to forbid any cover, if it is evident that the cover is damaged or ineffective.

### **2.6.6.31 Transmission / gearbox**

All transmission/gearbox ratios, shafts, shift drum and selector forks may be altered or replaced.

Primary gears (and ratio) must remain as homologated.

#### **From 01/01/2023:**

**In addition of the articles here above, the number of possible sets of gearbox ratios is limited at 3 maximum per season and per manufacturer as follow:**

- **SET 1: Homologated gearbox ratios (as on the homologated model)**
- **SET 2: Declared for “Fast” track layout configuration**
- **SET 3: Declared for “Slow” track layout configuration**

**Each manufacturer (through the official representative of the brand involved in the FIM EWC Working Group or the appointed Endurance programme Manager)**

**must declare their 2 sets (SET 2 + SET 3) for the whole season. This declaration must cover all the models homologated to compete in Formula EWC to the FIM EWC Technical Director ([sptech@fim.ch](mailto:sptech@fim.ch) or [cti@fim.ch](mailto:cti@fim.ch)) in prior of the opening of the season.**

The layout of the transmission shafts must be the same as on the homologated motorcycle and only the material and the ratios can be changed.

The layout and function of the shift drum must be the same as on the homologated motorcycle.

The selector forks may be changed; however, the forks must engage with the same gears and function in the same way as on the homologated motorcycle.

Countershaft sprocket, rear wheel sprocket, chain pitch and size can be changed.

The drive sprocket cover can be modified or eliminated. A crankcase protection may be added in this area (against chain damage).

The chain guard (swingarm mounted) may be removed or replaced.

No power source (i.e. hydraulic or electric) can be used for gear selection, if not installed in the homologated model for road use.

Human power and so called 'quick shifter' systems are excluded from the ban.

Seamless shift gearboxes are not allowed unless if fitted on the homologated motorcycle.

#### **2.6.6.32 Clutch**

The original clutch assembly may be modified or replaced.

A back-torque limiter ('slipper' clutch) is permitted.

Any power source (i.e. hydraulic or electric) cannot be used for clutch operation, if not installed in the homologated model for road use. Human power is excluded from the ban

Clutch type (wet or dry) and the way of operation (by cable or hydraulic) must remain as homologated.

#### **2.6.6.33 Ignition / engine control system**

The ignition/engine control system (ECU) and its software may be modified or changed; its position may be changed (relocated).

Spark plugs, spark plug caps and wires may be replaced.

#### **2.6.6.34 Generator, alternator, electric starter**

The generator, electric starter, starter crank gear and starter shaft may be altered or replaced from those fitted to the homologated motorcycle.

The electric starter must operate normally and always be able to start the engine during the event. The engine must keep running on its own power when the electric starter has stopped its procedure.

The voltage regulator (rectifier) may be changed.

#### **2.6.6.35 Lights**

Headlights must emit a WHITE light beam (**refer to art. 2.3.11 Electrical equipment (lights) and electroluminescent numbers**).

#### **2.6.6.36 Exhaust system**

The exhaust system may be modified for racing use. Catalytic converters must be removed. O<sub>2</sub> and equivalent sensors may be removed.

The number of the exhaust silencer(s) must remain as homologated. The position if the silencer silencer(s) (left or right, up or down) is free. The silencer's end must not pass a vertical line drawn at the edge of the rear tyre. The silencer's end cap may be made of composite materials.

For safety reasons, the exposed edge(s) of the exhaust pipe(s) outlet(s) must be 'rounded (diameter: min. 1 mm), avoid any sharp edges and be kept within 5 mm of the end cap of the silencer.

The silencer exhaust mounting/support flange may be made of composite materials; the assembly has to be secured by means of screws and bolts. Quick 'zip' ties are not allowed.

Wrapping of exhaust systems is not allowed except in the area of the rider's foot or an area in contact with the fairing for protection from heat.

**For the Sound Control (Art. 2.14), no modification (by any possible way) of the original RPM channel is allowed. The RPM information displayed on the dashboard and shown by the team must be the real engine revolution. Furthermore, all systems as "home-made" dB-Killers (not delivered as original part or accessory of the silencer / exhaust line) are strictly forbidden. All these cheating systems will be strongly penalized.**

#### **2.6.7 The following items MAY BE altered or replaced from those fitted to the homologated motorcycle**

- A special 'one-way' valve can be fitted to the crankcase oil filler opening (to avoid any oil spillage).
- It is recommended that motorcycles be equipped with a red light on the instrument panel. This light must flash in the event of oil pressure drop.
- Tachometer
- Any type of lubrication, brake or suspension fluid may be used.
- Any type of tubing (i.e. air, fuel, oil or water) may be used.
- Any inner tube (if fitted) or inflation valves may be used.

- Gaskets and gasket material.
- Wheel balance weights may be discarded, changed or added to.
- Bearings (ball, roller, taper, plain, etc.) of any type or brand may be used.
- Fasteners (nuts, bolts, screws, etc.).
- External surface finishes and decals on fairing and bodywork.

#### **2.6.8 The following items MAY BE removed**

- The air injection control system (valve, solenoid, tubes) may be removed. The tubes connected to the cylinder head cover may be plugged.
- Unused elements of the wiring harness
- Instrument and instrument bracket and associated cables.
- Tachometer.
- Speedometer and associated wheel spacers.
- Chain guard
- Bolt on accessories on a rear sub frame (seat).

#### **2.6.9 The following items MUST BE removed**

- Turn signal indicators (when not incorporated in the fairing). The openings in the fairing must be covered by a suitable material.
- Rear-view mirrors.
- Horn.
- License plate bracket.
- Tool box.
- Helmet hooks and luggage carrier hooks
- Passenger foot rests.
- Passenger grab rails.
- Safety bars, centre and side stands must be removed (fixed brackets must remain).

#### **2.6.10 The following items MUST BE altered**

- Motorcycles must be equipped with a functional ignition kill switch or button (RED), mounted on the handlebar, capable of stopping a running engine and within reach of the hand while on the hand grips.
- Throttle controls must be self closing when not held by the hand.
- All drain plugs must be wired. External oil filter(s) screws and bolts that enter an oil cavity must be safety wired (i.e. on crankcases, hoses, oil radiators, etc.).
- All motorcycles must have a closed circuit breather system. The oil breather line must be connected and discharge into the airbox.
- Where breather or overflow pipes are fitted they must discharge via existing outlets into the airbox. The original closed system must be retained; no direct atmospheric emission is permitted.
- Oil cooler must not be mounted on or above the rear mudguard.

#### **2.6.11 Additional equipment**

Additional electronic hardware equipment not on the original homologated motorcycle may be added (this permission refers to: data acquisition and sensors, computers, recording equipment).

On-board cameras may only be used upon request and after the team has obtained written permission from the FIM and the Promoter. It is forbidden to use, mount or affix cameras on the rider's helmet.

The addition of a device for infra red (IR) transmission of a signal between the racing rider and his team, used exclusively for laptiming, is allowed.

The addition of a GPS unit for positioning, laptiming and/or lapscoreing purposes or legible messages via an on-board screen is allowed.

Telemetry is not allowed (remote signals to or from the motorcycle), except for the compulsory championship devices.

Remote or wireless connections to the motorcycle for any data exchange or setting is not allowed whilst the engine is running or the motorcycle is moving.

The use of bi-directional communication is not allowed except when mentioned in the Supplementary **Regulations** or by the request of the Race Direction and with the approval of the FIM **EWC** Technical Director.

The addition of all Championship contracted devices such as Transponder and Promoter's on-board TV system is allowed. The Promoter is requested to advise the FIM **EWC** Technical Director of the list of motorcycles on which their systems will be fitted in prior of the race.

One extra mechanic (a 5<sup>th</sup> one **identified with a special chasuble given by the Promoter**) will be allowed during the pitstop only to manage these TV devices following the Promoter's instructions.

## 2.7 SUPERSTOCK TECHNICAL SPECIFICATIONS

### EVERYTHING THAT IS NOT PRESCRIBED OR SPECIFICALLY ALLOWED IN THESE REGULATIONS IS STRICTLY FORBIDDEN

Formula Superstock motorcycles require an FIM “Superstock” Homologation. The homologated “Superstock” model must not exceed a maximum retail price of 33.000 Euros (incl. taxes).

(The FIM Homologation procedure is available on [www.fim-moto.com](http://www.fim-moto.com) in the “Documents” section on the main page).

All motorcycles entered in the Formula SUPERSTOCK class must comply in every respect with all the requirements for Circuit Racing as specified in these Technical Regulations, unless they are already equipped as such on the homologated model.

The appearance from both front, rear and the profile of Formula SUPERSTOCK motorcycles for Endurance must (except when otherwise stated) conform in principle to the homologated shape (as originally produced by the manufacturer). The appearance of the exhaust system is excluded from this rule; the silencer(s) must remain on the same side as homologated on the original model.

#### 2.7.1 Engine configurations and displacement capacities

The following engine configurations comprise the Superstock class:

Over 750cc up to 1000cc	4-stroke	3 & 4 cylinders
Over 850cc up to 1200cc	4-stroke	2 cylinders

The displacement capacity **and** bore and stroke must remain at the homologated size.

#### 2.7.2 Minimum weight

All machines: 168 kg for all races.

This is the absolute minimum weight (without the fuel tank and its content).

(“Its content” includes: fuel on-board, all fuel tank internal parts, fuel valve(s) system (+ protective cover (if any)), fuel pump, glued protective covers/rider anti-slip systems).

At any time during the event, the weight of the whole motorcycle (excluding the fuel tank and its content) must not be less than the minimum weight.

There is no tolerance on the minimum weight of the motorcycle.

The use of ballast is allowed to stay over the minimum weight limit and may be required due to a handicap system. The use of ballast and weight handicap must be declared to the FIM **EWC** Technical Director / Chief Technical Steward at the preliminary checks and/or prior to the race.

During the practice and qualifying sessions, riders may be asked to submit their motorcycle to a weight control in the pit lane. The minimum weight during the QPs remains at 175 kg (including the fuel tank and its content).

In all cases the rider (and the team) must comply with this request for a control. Any “forcing” of the control point of the weight control will be immediately reported to the FIM EWC Stewards Panel who will take appropriate action (see **Sporting Regulations**).

During the **Final Technical Inspection** at the end of each race, the selected motorcycles will be weighed in the condition they finished the race (without the fuel tank and its content), and the established weight limit must be met in this condition. Nothing may be added to the motorcycle. This includes all fluids.

The minimum weight includes all Championship contracted devices whether fitted or not, such as **t**ransponder and on-board TV system.

#### **2.7.4 Carburation instruments**

Carburation instruments (fuel injection system, etc.), must remain as homologated. No modifications are authorized.

#### **2.7.5 Fuel**

**All teams must use the fuel provided by the appointed single fuel supplier contracted for the FIM Endurance World Championship/Cup if any (except for Le Mans).**

All engines must function on normal unleaded fuel with a maximum lead content of 0.005 g/l (unleaded) and a maximum MON of 90 (see Art. 2.10 for full specification)

#### **2.7.6 Motorcycle specifications**

All parts and systems not mentioned in the following articles must remain as originally produced by the manufacturer for the homologated motorcycle.

##### **2.7.6.1 Main **f**rame body and **r**ear subframe**

The main frame must be the originally manufactured part produced and fitted by the manufacturer and be used on all the units produced following the homologated motorcycle model.

The main frame may only be modified by the addition of gussets or tubes. No gussets or tubes may be removed, other modifications are allowed within the following section of these rules:

Holes may be drilled on the frame only to fix authorised components (i.e. fairing brackets, steering damper mount, sensors.).

The main frame must have a **V**ehicle **I**dentification **N**umber (VIN), as issued by the manufacturer on the homologated model. Any other frame (i.e. originating as ‘spare part’) must be identical to the original homologated part, and correspond to all the

dimensions on the homologation drawings. Such main frame must be identified by permanent method by a special and unique number. (Example: "YEAR - TEAM - 01")

Protective covers made from composite materials to protect a section of a frame are permitted and must be attached securely. Drilling holes to attach these covers is not permitted. For the Technical Inspections, the motorcycles must be presented without these protective covers. The FIM **EWC** Technical Director may ask the team at any time of the event to take off these covers for further verifications.

Adequate space must be available to affix the FIM Technical verification sticker (on a smooth surface).

Nothing else may be added or removed from the frame body.

Engine mounting brackets or plates must remain as originally produced by the manufacturer for the homologated motorcycle.

The homologated rear sub-frame construction may be modified or replaced, but the design, purpose and assembly must remain as used by the homologated part. The material used must remain as homologated or of higher specific weight.

The material for the seat pad may be modified and/or replaced.

The material of the streamlining/seat section may be replaced, but the homologated shape/profile must remain as homologated.

Additional seat brackets may be added but original ones cannot be removed; non-stressed protruding brackets may be removed if they do not affect the safety of the construction or assembly.

Bolt-on accessories to the rear sub-frame may be removed.

The paint scheme is not restricted but polishing the frame body or sub frame is not allowed.

#### **2.7.6.2 Front fork**

Forks, stanchions, stem, wheel spindle, upper and lower crown, etc., must remain as originally produced by the manufacturer for the homologated motorcycle.

Original internal parts of the homologated forks may be modified or changed. After market damper kits or valves may be installed.

No aftermarket or prototype electronically-controlled suspension parts may be used, unless such suspension is already present on the production model of the homologated motorcycle, and it must remain completely standard (all mechanical or electronic parts must remain as homologated). The original suspension system must work safely in the event of an electronic failure.

Any quality and quantity of oil can be used in the front forks.

The fork caps can be modified or replaced to allow external adjustment.

Dust seals can be modified changed or removed providing the fork remains totally oil-sealed.

The original surface finish of the fork tubes (stanchions, fork pipes) may be changed. Additional surface treatments are allowed.

The height and position of the front fork in relation to the fork crowns is free.

The upper and lower fork clamps (triple clamp, fork bridges) must remain as originally produced by the manufacturer on the homologated motorcycle.

A steering damper may be added or replaced with an after-market damper.

The steering damper cannot act as a steering lock limiting device.

### **2.7.6.3 Swingarm**

Every part of the rear swingarm must remain as originally produced by the manufacturer for the homologated motorcycle (including rear fork pivot bolt and rear axle adjuster).

Protective covers made from composite materials to protect a section of a swingarm are permitted and must be attached securely. Drilling holes to attach these covers is not permitted. For the Technical Inspections, the motorcycles must be presented without these protective covers. The FIM **EWC** Technical Director may ask the team at any time of the event to take off these covers for further verifications.

A rigid chain guard must be fitted in such a way to reduce the possibility that any part of the riders' body may become trapped between the lower chain run and the rear wheel sprocket. This lower chain guard (a.k.a. shark-fin) must cover the opening where the chain meets the rear sprocket. Chain guards must be made of strong material and resist any bending (steel, aluminium, composites).

Rear swingarm pivot bolt must remain as originally produced by the manufacturer for the homologated motorcycle.

An anchorage system or point(s) to keep the original rear brake caliper in place may be added to the rear swingarm.

Rear wheel stand brackets may be added to the rear swingarm by welding and/or attached by bolts.

These brackets (in steel or aluminium, fitted behind or below the swingarm) must respect maximum dimensions (measured all around the swingarm) for length x height: 120 mm x 120 mm) with a minimum thickness of this part of 6 mm. All edges must be rounded and face inwards.

Fastening screws must be recessed. A small bracket to retain the chain (steel, aluminium) is permitted, securely mounted, edges must be rounded. Max dimensions: length: 40 mm; height above the swingarm: 40 mm; width/thickness: 10 mm).

#### **2.7.6.4 Rear suspension unit(s)**

Rear suspension unit (shock absorber) may be modified or replaced, but the original attachments to the frame and rear swingarm must be as homologated.

Rear suspension unit spring(s) may be changed.

No aftermarket or prototype electronically-controlled suspension unit maybe used, unless such suspension is already present on the production model of the homologated motorcycle, and it must remain completely standard (any mechanical or electronic parts must remain as homologated). The original suspension system must work properly safely in the event of an electronic failure.

The rear suspension linkage must remain as originally produced by the manufacturer for the homologated motorcycle.

#### **2.7.6.5 Wheels**

Wheels must remain as originally produced by the manufacturer for the homologated motorcycle.

The speedometer drive may be removed and replaced with a spacer.

If the original design includes a cushion drive for the rear wheel, it must remain as originally produced for the homologated motorcycle.

No modifications of the wheel-axles or any fixing and mounting points for front brake caliper are authorised. Internal and external spacers may be modified. Modifications to the wheels to keep spacers in place are permitted.

Wheel balance weights may be discarded, changed or added to.

Any inner tube (if fitted) or inflation valves may be used.

#### **2.7.6.6 Brakes**

Brake discs may be replaced by aftermarket discs which comply with following requirements:

Replacement brake discs must be of ferrous materials. Internally ventilated discs are not allowed.

The outside and inner diameters of the brake disc must not be larger than the ones on the homologated disc.

The thickness of the brake disc may be increased but the disc must fit into the homologated brake caliper without any modification to the caliper.

Front brake discs can be made floating, using original rotors. The number of floaters is free.

Brake disc carriers may be changed, but must retain the same off-set and same type of mounting to the wheels.

The front brake master cylinder may be replaced. The rear brake master cylinder must remain as on the homologated motorcycle. The front and rear brake fluid reservoirs may be replaced and/or repositioned.

The air bleeder screw on the originally homologated calipers may be replaced.

The front and rear brake caliper (mount, carrier, hanger) must remain the one as originally produced by the manufacturer for the homologated motorcycle.

Front brake system cooling airducts are allowed. A (1) duct must be fitted between the front brake caliper and the front brake caliper bracket. However, no modifications to the front brake calipers are allowed.

Air ducts shall be routed to cool the discs or directed onto the brake caliper bodies. Viewed from the side, the airducts opening shall not pass the vertical line drawn by the front axle shaft. Viewed from the front, the airducts must fall inside the shape drawn by the fairing (aerodynamic winglets excluded) and must be positioned as close as possible to the front fork leg/foot. For safety reasons, the airflow shall not be directed onto the brake pads.

The air-ducts may be made of composite materials. The complete assembly must be presented and validated by the FIM **EWC** Technical Director in prior of its use.

In order to reduce the transfer of heat to the hydraulic fluid it is permitted to add metallic shims (**spacers**) to the calipers, between the pads and the calipers, and/or to replace light alloy pistons with steel pistons made by the same manufacturer of the caliper. The use of magnets or magnetized shims is not permitted.

The rear brake caliper bracket may be mounted 'fixed' on the swingarm, but the bracket must maintain the same mounting (fixing) points for the caliper as used on the homologated motorcycle. A modification of the rear caliper bracket in part is authorised. The swingarm may be modified for this reason to aid the location of the rear brake caliper bracket, by welding, drilling or by using a helicoil.

The original chain adjusters (round or square) may be drilled to keep the rear brake caliper bracket in place.

Front and rear hydraulic brake lines may be changed.

"Quick" (or "dry-brake") connectors in the brake lines are authorised.

The split of the front brake lines for both front brake calipers must be made above the lower fork bridge (lower triple clamp). Brake line hose fittings (including banjo bolts) can only be **steel** or **titanium**. Quick couplings can remain in **aluminium**.

Front and rear brake pads may be changed. Brake pad locking pins may be modified for quick change type.

The Antilock Brake System (ABS) may be used only if installed in the homologated model for road use. The type of system (mechanical or electronic) and the ABS pump/pressure regulator must remain as homologated on the the homologated motorcycle. Discs, speed sensor (rotor), master cylinder and the software of the ABS may be modified or replaced. Only ferrous materials are allowed for brake discs.

The Anti Lock Brake system (ABS) can be disconnected and the ABS pump/pressure regulator can be deleted.

#### **2.7.6.7 Tyres**

See Art. 2.3.6.

#### **2.7.6.8 Handlebars and hand controls**

Only one (1) RED engine stop switch may be located on the left or right handle bar, **reachable from the rider with the rider's hand on the grip.**

Throttle controls must be self closing when not held by the hand.

Handlebars, hand controls and associated cables may be altered or replaced from those fitted to the homologated motorcycle (see Art. 2.3.4), but all hand controls, electric starter switch and engine stop switch must remain on the handlebars. Other switches may be changed.

Clutch and brake lever may be replaced with an aftermarket model (see also Art. 2.3.4).

It is compulsory to equip all motorcycles with a solid brake lever guard preventing the brake lever from being accidentally activated in case of collision with another motorcycle.

#### **2.7.6.9 Footrest / foot controls**

Foot rest/foot controls may be relocated but brackets must be mounted to the frame in the original mounting points. Their two original points of fixture (for the footrest, foot-controls and on the shift shaft) must remain as original. Foot controls linkage may be modified. The original mounting points must remain.

Foot rests may be rigidly mounted or a folding type which must incorporate a device to return them to the normal position.

The end of the foot rest must have at least an 8 mm solid spherical radius. (see Diagram A & C).

Non-folding footrests must have an end (plug) which is permanently fixed, made of plastic, Teflon® or an equivalent type material (minimum radius 8mm). The plug surface must be designed to reach the widest possible area. The FIM **EWC** Technical Director / Chief Technical Steward has the right to refuse any plug not satisfying this safety aim.

#### 2.7.6.10 Fuel tank

The original fuel tank may be modified or replaced by a copy to achieve the maximum capacity of 24 litres, provided that the homologated appearance and location are maintained; however, its actual shape can be slightly changed to suit the rider's preference.

**All fuel tanks must be filled with fire retardant material (open-celled mesh, i.e. "Explosafe®, ExploStop®").**

The fuel tank used during practice must be of the same size (**max. capacity 24L**) and **be fitted with the same type quick fill fuel valve system** during the entire event.

The fuel tank may be modified and extended below the upper frame line. The extended part of the fuel tank shall remain protected by the seat sub-frame (in case of a crash) and the underside shielded by a protective cover. Whatever the position of the rear wheel, it shall not touch this protective cover of the extended fuel tank (minimum clearance between the wheel and the protective cover: 10mm). The modified fuel tank shall not extend past a vertical line drawn through the rear wheel axle.

The material used in the construction of the fuel tank may be altered from the homologated material fitted on the homologated motorcycle. Other than steel, only aluminium must be used in the construction of the fuel tank. The minimum wall thickness will be 1.2 mm.

Carbon or aramid fibres or fibreglass materials are not authorised in the construction of fuel tanks.

Protective tank covers **must** be fitted on the exposed edges (**in case of crash**) of tanks made of steel. **These protectors must fit the shape of the fuel tank.** These covers must **be** presented and the application validated by the FIM **EWC** Technical Director (from 01/01/2022).

The fuel tank must be fixed to the frame from the front and the rear with a crash-proof assembly system, with a minimum of 3 bolts of 5mm diameter (or more). Bayonet style couplings can not be used, nor any fixing to any parts of the streamlining. The FIM **EWC** Technical Director / Chief Technical Steward have the right to refuse a motorcycle if he is of the opinion that the fuel tank fixation method is not safe.

Fuel tanks with tank breather pipes must be fitted with non-return valves which discharge into a catch tank with a minimum volume of 250 cc **and a maximum volume of 350cc** made of a suitable material.

**Until 31/12/2022:** The fuel tank filler cap must be replaced by a 'quick-fill' type and when closed, must be leak proof. Any tampering to the opening or closing of the quick fuel valve system of the fuel tank will be considered as an infraction to the safety requirement (leak proof). Additionally, the system must be secured to prevent accidental opening at any time (See also Art. 2.3.15).

**From 01/01/2023 to 31/12/2031 (2 periods of 5 years (2022: transition year)-2026 and 2027-2031):**

**The original fuel tank cap must be replaced by the following FIM Homologated Fuel Quick Fill System (parts list detailed hereunder):  
FIM EWC Parts list - 8000115196F (or latest update) downloadable on the FIM official website [www.fim-moto.com](http://www.fim-moto.com).**

**No modification of any parts of the original homologated system (presented in the parts list here above) is allowed.**

**All teams must use the same specification as described in the latest Parts list. The list of the Homologated Parts (including older tank plug for example) is downloadable on the FIM official website [www.fim-moto.com](http://www.fim-moto.com).**

**The PLUG CAP (P/N 100041568 or latest part reference) must be back in place to release the motorcycle in the pitlane. In case this part is lost during a session or stint, the team will have to reup a new one after the next pitstop.**

#### **2.7.6.11 Fairing / body work**

- a) Fairing and body work may be replaced with exact cosmetic duplicates of the original parts, but must appear to be as originally produced by the manufacturer for the homologated motorcycle, with slight differences due the racing use (different pieces mix, attachment points, fairing bottom, etc). The material may be changed. The use of carbon fibre or carbon composite materials is not allowed. Specific reinforcements in kevlar or carbon are authorized locally around holes and stressed areas.
- b) Overall size and dimensions must be the same as the original part.
- c) Wind screen may be replaced with a duplicate of transparent material. The height of the windscreen is free, within a tolerance of +/- 15 mm regarding to the vertical distance from to the upper fork bridge.
- d) Motorcycles that were not originally equipped with streamlining are not allowed to add streamlining in any form, with the exception of a lower fairing device, as described in (h). This device cannot exceed above a line drawn horizontally from wheel axle to wheel axle.
- e) The original combination instrument/fairing brackets may be replaced, but the use of titanium and carbon (or similar composite materials) is forbidden. All other fairing brackets may be altered or replaced.
- f) The original air ducts running between the fairing and the air box may be altered or replaced. Carbon fibre composites and other exotic materials are forbidden. Particle grills or "wire-meshes" originally installed in the openings for the air ducts may be taken away.

Any fixing point(s) for the front/rear wheel stand must be bolted to either, the frame, engine block or rear fork (swingarm). No element of this support can exceed any part of the fairing. Only modifications made to the fairing in order to accept this element are allowed. The maximum clearance between this device and the fairing is 5 mm.

- g) The lower fairing has to be constructed to hold, in case of an engine breakdown, at least half of the total oil and engine coolant capacity used in the engine (minimum 5 litres). The lower edge of openings in the fairing must be positioned at least 50 mm above the bottom of the fairing.

Original openings for cooling in the lateral fairing/bodywork sections may be partially closed only to accommodate sponsors' logos/lettering. Such modification shall be made using wire mesh or perforated plate ('the material is free but the distance between all opening centres, circle centres and their diameters must be constant'). Holes or perforations must have an open area ratio > 60%.

The lower fairing section must remain leak proof at all times. (A hole of 25 mm is no longer required). The rear of the lower fairing must be fixed by a minimum of two brackets **or bolts** to the engine or to the frame to carry the lower fairing when filled with liquid.

- h) Front **fender** may be replaced with a cosmetic duplicate of the original part. All the dimensions, including the mounting points must remain exactly as original. The material is free. 'Flexible' mounts by "dzeus" fasteners, clips, 'zip' tie-raps, clamps, etc. are not permitted.
- i) Rear **fender** fixed on the swing arm may be modified, replaced or deleted but the original shape must be respected.
- j) Additional heatshield made from composites may be installed on the rear exhaust pipe section and running up and inside the rider's footrest. This heatshield **cannot have any aerodynamic purpose and be used as such**. The appreciation of this piece remains a decision of the FIM **EWC** Technical Director.

#### **2.7.6.12     Seat**

Seat, seat base and associated body work may be replaced with parts of similar appearance as originally produced by the manufacturer for the homologated motorcycle. The appearance from front, rear and profile must conform to the homologated shape.

The top portion of the rear body work around the seat may be modified to a solo seat.

The seat/rear cowl replacement must allow for proper number display.

The homologated seat locking system (with plates, pins, rubber pads etc.) may be removed.

#### **2.7.6.13     Wiring **harness** and **tachometer** (rpm gauge)**

The original wire-loom may be modified, replaced or relocated.

The original tachometer must be used.

The ignition key/lock may be relocated.

#### **2.7.6.14 Battery**

The battery may be replaced. If replaced, its nominal capacity (C/1) must be equal to or higher than the homologated type.

**For safety reasons, whatever is the technology of the battery used, no charging is allowed without any surveillance and during the night (in the pitbox or in the team' truck). The charging area must be safe as possible and as far away as possible of any fuel cans.**

#### **2.7.6.15 Radiator, cooling system and oil coolers**

Protective meshes may be added in front of the oil and/or water radiator(s).

The radiator tubes/hoses to and from the engine may be replaced. The original heat exchanger (oil/water) may be replaced by an oil-cooler and its tubes separated from the cooling circuit. Overflow tanks may be changed but must be fixed in a secure way.

Radiator fan and wiring may be removed. Thermal switches, water temperature sensor and thermostat may be removed inside the cooling system.

Radiator cap is free.

An additional water radiator may be fitted but the appearance of the front, the rear and the profile of the motorcycle must not be changed. Extra mounting brackets to accommodate the additional radiator are permitted.

An additional oil cooling radiator may be fitted either under or behind the water radiator(s) but the appearance of the front, the rear and the profile of the motorcycle must not be changed. Extra mounting brackets to accommodate the additional radiator are permitted.

#### **2.7.6.16 Airbox**

The air box must remain as originally produced by the manufacturer on the homologated motorcycle but the air box drains must be sealed.

The air filter element may be modified or replaced.

All motorcycles must have a closed breather system. The oil breather line must be connected and discharge in the airbox.

#### **2.7.6.17 Fuel injection system**

Fuel injection systems refer to throttle bodies, fuel injectors, variable length intake tract devices, fuel pump and fuel pressure regulator.

The original homologated fuel injection system must be used without any modification.

The fuel injectors must be stock and unaltered from the original specification and manufacture.

Bell mouths must be as originally produced by the manufacturer for the homologated motorcycle.

Throttle valves (butterfly valves) cannot be changed nor modified.

Variable intake tract devices cannot be added if they are not present on the homologated motorcycle and they must remain identical and operate in the same way as the homologated system. All the parts of the variable intake tract device must remain exactly as homologated.

Air and air/fuel mixture can go to the combustion chamber exclusively through the throttle body butterflies.

Electronically controlled throttle valves, known as 'ride-by-wire', may be only used if the homologated model is equipped with the same system. Software may be modified but all the safety systems and procedures designed by the original manufacturer must be maintained.

#### **2.7.6.18 Fuel supply**

Fuel pump and pressure regulator **cannot** be modified.

The original fuel valve (petcock) may be altered, replaced or removed from those installed on the homologated motorcycle.

Quick connectors or dry break quick connectors may be used.

Fuel lines from the fuel tank up to the injectors (fuel hoses, delivery pipe assembly, joints, clamps, fuel canister) may be replaced, without increasing the fuel volume.

The fuel line(s) going from the fuel tank to the fuel injection instruments must be located in such a way that they are protected from possible crash damage.

A cross over line between each side of the tank is allowed (maximum inside diameter 10 mm).

Fuel vent lines may be replaced.

Fuel filters may be added.

#### **2.7.6.19 Cylinder head**

No modifications are allowed.

No material may be added or removed from the cylinder head.

The cylinder head gaskets may be changed.

The valves, valve seats, guides, springs, tappets, oil seals, shims, cotter valve, spring base and retainers must be as originally produced by the manufacturer for the homologated motorcycle. Only normal maintenance interventions as prescribed by the **m**anufacturer in the model's Service Manual are authorised.

Valve spring shims are not allowed.

#### **2.7.6.20 Camshaft**

No modifications are allowed.

**Camshafts must remain as homologated (no kit-camshafts; valve lift, cam-lobe lift and contour of the lobe must be as homologated).**

At the technical checks: for direct cam drive systems, the cam lobe lift is measured; for non-direct cam drive systems (i.e. with rocker arms), the valve lift is measured.

The camshaft 'timing' (degreeing) may be modified.

#### **2.7.6.21 Cam sprockets or gears**

**Cam sprockets or cam gears may be modified or replaced to allow the degreeing of camshafts.**

#### **2.7.6.22 Cylinders**

No modifications are allowed.

#### **2.7.6.23 Pistons**

No modifications are allowed (including polishing and lightening).

#### **2.7.6.24 Piston rings**

No modifications are allowed.

#### **2.7.6.25 Piston pins and clips**

No modifications are allowed.

#### **2.7.6.26 Connecting rods**

No modifications are allowed (including polishing and lightening).

#### **2.7.6.27 Crankshaft**

No modifications are allowed (including polishing and lightening).

#### **2.7.6.28 Crankcase, other engine cases and covers (ignition case, clutch case, etc.)**

Crankcases must remain as homologated. No modifications are allowed (including painting, polishing and lightening).

The oil sump must remain as homologated.

It is not allowed to add a pump used to create a vacuum in the crankcase. If a vacuum pump is installed on the homologated motorcycle then it may be used only as homologated.

All lateral covers/engine cases containing oil and which could be in contact with the ground during a crash, must be protected by a second cover made from metal, such as aluminium alloy, stainless steel, steel.

Plates or crash bars made from aluminium or steel also are permitted in addition to these covers. All of these devices must be designed to be resistant against sudden shocks, abrasions and crash damage.

FIM protective covers declared eligible for competition will be permitted without regard of the material.

These covers must be fixed properly and securely with case cover screws/bolts (minimum 3 fixing points) that also mount the original covers/engine cases to the crankcases.

The **FIM EWC** Technical Director has the right to forbid any cover, if the evidence shows the cover is not effective.

#### **2.7.6.29      Transmission / gearbox**

No modifications are allowed.

An external quick-shift system on the gear selector (including cable and potentiometer) may be added.

Other modifications to the gearbox or to the selector mechanism are not authorised.

Countershaft sprocket, rear wheel sprocket, chain pitch and size can be changed.

The drive sprocket cover can be modified or eliminated. A crankcase protection may be added in this area (against chain damage).

The chain guard (swingarm mounted) may be removed or replaced.

#### **2.7.6.30      Clutch**

No modifications are allowed.

Only friction and drive discs may be changed, but their number must remain as original.

Clutch springs may be changed.

#### **2.7.6.31      Oil Pumps and oil lines**

No pump modifications are allowed.

Oil lines may be modified or replaced. Oil lines containing positive pressure, if replaced, must be of metal reinforced construction with swaged or threaded connectors.

#### **2.7.6.32 Electronic control system**

The engine control system (including ECU and dashboard) must be either:

- The standard system as on the homologated motorcycle (STD).
- The manufacturer's official Superstock 1000 Kit system (KIT).

The location and the size of the Electronic Control Unit (ECU) must be identical to the original, homologated unit.

Whatever the engine control system used by the team (STD or KIT), the ECU must be clearly identified by the original serial number issued by the manufacturer at the production of the ECU.

The manufacturer must declare this list of serial numbers (including ECU STD and KIT) to the FIM EWC Technical Director before the opening of the season at [sptech@fim.ch](mailto:sptech@fim.ch).

The ECU serial number used by the team must comply with the model and the years range of the motorcycle homologated by the FIM and declared by the manufacturer.

The ECU must be set following the manufacturer's instructions (user manual).

At all times, the FIM EWC Technical Director (or his appointed colleague) must have access and way to connect to the ECU, for controlling purposes.

Spark plugs may be replaced.

#### **2.7.6.33 Generator, alternator, electric starter**

No modifications are allowed.

The electric starter must operate normally and always be able to start the engine during the event.

#### **2.7.6.34 Exhaust system**

The exhaust system may be modified for racing use. Catalytic converters must be removed. O<sub>2</sub> and equivalent sensors may be removed.

The number of the exhaust silencer(s) must remain as homologated. The position of the silencer(s) (left or right, up or down) is free. The silencer's end must not pass a vertical line drawn at the edge of the rear tyre. The silencer's end cap may be made of composite materials.

For safety reasons, the exposed edge(s) of the exhaust pipe(s) outlet(s) must be rounded (diameter: min. 1 mm), avoid any sharp edges and be kept within 5 mm of the end cap of the silencer.

The silencer exhaust mounting/support flange may be made of composite materials; the assembly has to be secured by means of screws and bolts. Quick 'zip' ties are not allowed.

Wrapping of exhaust systems is not allowed except in the area of the riders foot or an area in contact with the fairing for protection from heat.

**For the Sound Control (Art. 2.14), no modification (by any possible way) of the original RPM channel is allowed. The RPM information displayed on the dashboard and shown by the team must be the real engine revolution. Furthermore, all systems as "home-made" dB-Killers (not delivered as original part or accessory of the silencer / exhaust line) are strictly forbidden. All these cheating systems will be strongly penalized.**

#### **2.7.6.35 Lights**

Headlights must emit a YELLOW light beam (refer to art. 2.3.11 Electrical equipment (lights) and electroluminescent numbers).

#### **2.7.6.36 Fasteners**

Standard fasteners may be replaced with fasteners of any material and design but titanium fasteners may not be used. The strength and design must be equal to or exceed the strength of the standard fastener it is replacing.

Fasteners may be drilled for safety wire, but any intentional weight savings modifications are not allowed.

Fairing/bodywork fasteners may be changed to the quick disconnect type.

Aluminium fasteners may only be used in non-structural locations.

#### **2.7.7 The following items MAY BE altered or replaced from those fitted to the homologated motorcycle.**

- A special one-way valve can be fitted to the crankcase oil filler opening (to avoid any oil spillage).
- It is recommended that motorcycles be equipped with a red light on the instrument panel. This light must flash in the event of oil pressure drop.
- Any type of lubrication, brake or suspension fluid may be used.
- Any type of spark plug.
- Any inner tube (if fitted) or inflation valves may be used.
- Gaskets and gasket materials (with the exception of the cylinder base gasket).
- Wheel balance weights may be discarded, changed or added to.
- Instruments, instrument bracket(s) and associated cables,
- Painted external surface finishes and decals.
- Headlamp and rear lamp, only for races taking place partly at night.
- Material for brackets connecting non original parts (fairing, exhaust, etc) to the frame (or engine) cannot be made from titanium or fibre reinforced composites.

- Protective covers for engine (see also Art. 2.6.6.30 and 2.7.6.28), frame, chain, footrests, etc. can be made in other materials like fibre composite material if these parts do not replace original parts mounted on the homologated model.

### **2.7.8 The following items MAY BE removed**

- Emission control items (anti-pollution) in or around the air box and engine (O2 sensors, air injection devices).
- The air injection control system (valve, solenoid, tubes) may be removed. The tubes connected to the cylinder head cover may be plugged.
- Speedometer
- Chain guard
- Bolt on accessories on a rear sub frame.

### **2.7.9 The following items MUST BE removed**

- Turn signal indicators (when not incorporated in the fairing). The openings in the fairing must be covered by suitable materials.
- Rear-view mirrors
- Horn
- License plate bracket
- Tool box
- Helmet hooks and luggage carrier hooks
- Passenger foot rests
- Passenger grab rails
- Safety bars, centre and side stands must be removed (fixed brackets must remain).

### **2.7.10 The following items MUST BE altered**

- Motorcycles must be equipped with a functional ignition kill switch or button mounted at least on one side of the handlebar (within reach of the hand while on the hand grips) that is capable of stopping a running engine.
- Throttle controls must be self closing when not held by the hand.
- All drain plugs must be wired. External oil filter(s) screws and bolts that enter an oil cavity must be safety wired (i.e. on crankcases.)
- All motorcycles must have a closed breather system. The oil breather line must be connected and discharge in the airbox.
- Where breather or overflow pipes are fitted they must discharge via existing outlets. The original closed system must be retained; no direct atmospheric emission is permitted.

### **2.7.11 Additional equipment**

Additional electronic hardware equipment not on the original homologated motorcycle may be added (e.g. data acquisition and sensors, computers, recording equipment).

On-board cameras may only be used upon request and after the team has obtained written permission from the FIM and the Promoter. It is forbidden to use, mount or affix cameras on the rider's helmet.

The addition of a device for infra- red (IR) transmission of a signal between the racing rider and his team, used exclusively for laptiming, is allowed.

The addition of a GPS unit for positioning, laptiming and/or lapscoreing purposes or legible messages via an on-board screen is allowed.

Telemetry is not allowed (remote signals to or from the motorcycle), except by compulsory championship devices.

Remote or wireless connections to the motorcycle for any data exchange or setting is not allowed whilst the engine is running or the motorcycle is moving.

The use of bi-directional communication is not allowed except when mentioned in the Supplementary **Regulations** or by the request of the Race Direction and with the approval of the FIM **EWC** Technical Director.

The addition of all Championship contracted devices such as Transponder and Promoter's on-board TV system is allowed. The Promoter is requested to advise the FIM **EWC** Technical Director of the list of motorcycles on which their systems will be fitted in prior of the race.

One extra mechanic (a 5<sup>th</sup> one **identified with a special chasuble given by the Promoter**) will be allowed during the pitstop only to manage these TV devices following the Promoter's instructions.

## 2.9 EXPERIMENTAL TECHNICAL SPECIFICATIONS

EXPERIMENTAL type motorcycles may be based on road legal models with a valid FIM Homologation, or be a single unit.

When presented, the Team must show that the FIM Homologated motorcycle contains a major change to be considered as “Experimental”. Such project must have been validated by the CCR and the CTI prior to entering an event.

Either one of the following components: the engine, the main-frame or the suspension must be completely different in design and form from the original model to participate in the “Experimental” class.

All motorcycles must comply in every respect with all the requirements for Circuit Racing as specified in these Technical Regulations (including the safety requirements in Art.2.3).

Tyre limitations do not apply.

### 2.9.1 Displacement capacities

- 1) Internal combustion engines, naturally aspirated (fuel)

#### a. Homologated Superstock engines

Changes allowed as per the Superstock regulations (more specifically regarding the preparation of the engine components, airbox and fuel injection system, please refer to Art. 2.7 for details)

Over 750cc up to 1000cc	4-stroke	4 cylinders
Over 750cc up to 1000cc	4-stroke	3 cylinders

#### b. Prototype engine

Over 600cc up to 750cc	4-stroke	up to 4 cylinders
Over 750cc up to 1200cc	4-stroke	up to 3 cylinders

- 2) Hybrid system - Example: an alternative energy source in combination with Internal and naturally aspirated combustion engines: max 400cc
- 3) Other(s): i.e. electric

### 2.9.2 Transmission / gearbox

No limit on the number of gears.

### 2.9.3 Minimum / maximum weight

- The maximum weight for motorcycles with ELECTRIC power source: 250 kg.

For all motorcycles with internal combustion engines (ICE): 168 kg for all races.

This is the absolute minimum weight (without the fuel tank and its content).

("Its content" includes: fuel on-board, all fuel tank internal parts, fuel valve(s) system (+ protective cover (if any)), fuel pump, glued protective covers/rider anti-slip systems).

At any time during the event, the weight of the whole motorcycle (excluding the fuel tank and its content) must not be less than the minimum weight.

There is no tolerance on the minimum weight of the motorcycle.

The use of ballast is allowed to stay over the minimum weight limit and may be required due to a handicap system. The use of ballast and weight handicap must be declared to the FIM **EWC** Technical Director / Chief Technical Steward at the preliminary checks and/or prior to the race.

During the practice and qualifying sessions, riders may be asked to submit their motorcycle to a weight control in the pit lane. The minimum weight during the QPs remains at 175 kg (including the fuel tank and its content).

In all cases the rider (and the team) must comply with this request for a control. Any "forcing" of the control point of the weight control will be immediately reported to the FIM EWC Stewards Panel who will take appropriate action (see **Sporting Regulations**).

During the final **T**echnical **I**nspection at the end of each race, the selected motorcycles will be weighed in the condition they finished the race (without the fuel tank and its content), and the established weight limit must be met in this condition. Nothing may be added to the motorcycle. This includes all fluids.

The minimum weight includes all Championship contracted devices whether fitted or not, such as **t**ransponder and on-board TV system.

#### **2.9.4 Safety and construction criteria**

At all times, safety is the primary issue. Any motorcycle must adhere to the safety requirements.

In order to provide the participant the correct information, the entrant is required to submit a file of the 'Experimental' motorcycle, complete with full description, drawings and pictures of the motorcycle and of the powerplant used.

This file will be reviewed by the FIM Technical Commission and its Experts. They will provide their recommendations, if any, to the members of the Selection Committee.

#### **2.9.5 Fuel**

**Except special project based on the use of a special fuel specification (bio-fuels for example) approved upstream by the CCR/CTI, all the other teams using ICE (Internal Combustion Engines) must use the fuel provided by the appointed single fuel supplier contracted for the FIM Endurance World Championship/Cup if any (except for Le Mans).**

Motorcycles equipped with internal combustion engines must function on normal unleaded fuel with a maximum lead content of 0.005 g/l (unleaded) and a maximum MON of 90 (see also Art. 2.10 for fuel specifications).

Exceptions may be granted for alternative energies, provided that all safety measures with relation to stock, packaging and handling are taken and guaranteed at all times.

### **2.9.6 Fuel system**

The maximum permitted relative fuel pressure is 10 Bar, at a re-circulated flow rate of 50 litres/hour.

Additional regulators may be used in conjunction with the regulator to further reduce and control fuel pressure, but no device or strategy capable of increasing fuel pressure at the injectors above 10 Bar may be used anywhere in the system.

Teams must supply a schematic diagram of their fuel system including the location of the fuel pressure regulator when requested by the **FIM EWC** Technical Director.

### **2.9.7 General requirements**

All general requirements (See Art. 2.3) with relation to numbers, light installation, bodywork (See Art. 2.8.6.11) and quick fill fuel valve systems (if applicable) must all be observed.

### **2.9.8 Lights**

Headlights must emit a YELLOW light beam (**refer to art. 2.3.11 Electrical equipment (lights) and electroluminescent numbers**).

### **2.9.9 Materials for brakes**

Carbon composite or ceramic brakes are not permitted. Only ferrous materials are permitted.

The construction materials allowed for the main body of each component are:

Calipers, **m**aster **c**ylinders, **d**isc **m**ounting **h**ubs – Al2024, Al7075, Al6082, Al2618, Al6061 (Specifically Al-Li material is forbidden).

Brake line hose fittings (including banjo bolts) can only be **s**teel or **t**itanium. Quick couplings can remain in **a**luminium.

### **2.9.10 Fuel tank**

Fuel tanks must be made from metal or aluminium: follow Art. 2.6.6.10.

**All fuel tanks must be filled with fire retardant material (open-celled mesh, i.e. "Explosafe®, ExploStop®").**

**From 01/01/2023 to 31/12/2031 (2 periods of 5 years (2022: transition year)-2026 and 2027-2031):**

**The original fuel tank cap must be replaced by the following FIM Homologated Fuel Quick Fill System (parts list detailed hereunder):**

**FIM EWC Parts list - 8000115196F (or latest update) downloadable on the FIM official website [www.fim-moto.com](http://www.fim-moto.com).**

**No modification of any parts of the original homologated system (presented in the parts list here above) is allowed.**

**All teams must use the same specification as described in the latest Parts list. The list of the Homologated Parts (including older tank plug for example) is downloadable on the FIM official website [www.fim-moto.com](http://www.fim-moto.com).**

**The PLUG CAP (P/N 100041568 or latest part reference) must be back in place to release the motorcycle in the pitlane. In case this part is lost during a session or stint, the team will have to repute a new one after the next pitstop.**

### **2.9.11 Exhaust system**

The exhaust system may be modified for racing use. Exhaust pipes, catalytic converters and silencers may be altered or replaced from those fitted on a road legal motorcycle. Catalytic converters must be removed.

O<sub>2</sub> and equivalent sensors may be removed.

The number of the exhaust silencer(s) is free. The position if the silencer silencer(s) (left or right, up or down) is free. The silencer's end must not pass a vertical line drawn at the edge of the rear tyre. The silencer's end cap may be made of composite materials.

For safety reasons, the exposed edge(s) of the exhaust pipe(s) outlet(s) must be rounded (diameter: min. 1 mm), avoid any sharp edges and be kept within 5 mm of the end cap of the silencer.

The silencer exhaust mounting/support flange may be made of composite materials; the assembly has to be secured by means of screws and bolts. Quick 'zip' ties are not allowed.

Wrapping of exhaust systems is not allowed except in the area of the rider's foot or an area in contact with the fairing for protection from heat.

**For the Sound Control (Art. 2.14), no modification (by any possible way) of the original RPM channel is allowed. The RPM information displayed on the dashboard and shown by the team must be the real engine revolution. Furthermore, all systems as "home-made" dB-Killers (not delivered as original part or accessory of the silencer / exhaust line) are strictly forbidden. All these cheating systems will be strongly penalized.**

### **2.9.12 The following items MAY BE altered or replaced**

- A special 'one-way' valve can be fitted to the crankcase oil filler opening (to avoid any oil spillage). Standard or other valves must be secured.
- It is recommended that motorcycles be equipped with a red light on the instrument panel. This light must flash in the event of oil pressure drop.
- Tachometer
- Any type of lubrication, brake or suspension fluid may be used.
- Any type of tubing (i.e. air, fuel, oil or water) may be used.
- Any inner tube (if fitted) or inflation valves may be used.
- Gaskets and gasket material.
- Wheel balance weights may be discarded, changed or added to.
- Bearings (ball, roller, taper, plain, etc.) of any type or brand may be used.
- Fasteners (nuts, bolts, screws, etc.).
- External surface finishes and decals on fairing and bodywork.

### **2.9.13 The following items MAY BE removed**

- The air injection control system (valve, solenoid, tubes) may be removed. The tubes connected to the cylinder head cover may be plugged.
- Unused elements of the wiring harness
- Instrument and instrument bracket and associated cables.
- Tachometer
- Speedometer and associated wheel spacers.
- Chain guard
- Bolt on accessories on a rear sub frame (seat).

### **2.9.14 The following items MUST BE removed**

- Turn signal indicators (when not incorporated in the fairing). The openings in the fairing must be covered by a suitable material.
- Rear-view mirrors
- Horn
- License plate bracket
- Tool box
- Helmet hooks and luggage carrier hooks
- Passenger foot rests
- Passenger grab rails
- Safety bars, centre stands, side stands and fixed brackets must be removed.

### **2.9.15 The following items MUST BE altered**

- Motorcycles must be equipped with a functional ignition kill switch or button (RED) mounted at least on one handlebar to stop a running engine and within reach of the hand while on the hand grips.
- Throttle controls must be self closing when not held by the hand.
- The lower fairing section must remain leak proof at all times. (A hole of 25 mm is no longer required). The rear of the lower fairing must be fixed by a minimum of two brackets to the engine or to the frame to carry the lower fairing when filled with liquid.

- It is compulsory to equip all motorcycles with a solid front brake lever guard preventing the brake lever from being accidentally activated in case of collision with another motorcycle.
- All drain plugs must be wired. External oil filter(s) screws and bolts that enter an oil cavity must be safety wired (i.e. on crankcases).
- All motorcycles must have a closed circuit breather system. The oil breather line must be connected and discharge into the airbox.
- Where breather or overflow pipes are fitted they must discharge via existing outlets into the airbox. The original closed system must be retained; no direct atmospheric emission is permitted.
- Oil cooler must not be mounted on or above the rear wheel.

#### 2.9.16 Additional equipment

Additional electronic hardware equipment not on the original homologated motorcycle may be added (e.g. data acquisition and sensors, computers, recording equipment).

On-board cameras may only be used upon request and after the team has obtained written permission from the FIM and the Promoter. It is forbidden to use, mount or affix cameras on the rider's helmet.

The addition of a device for infra- red (IR) transmission of a signal between the racing rider and his team, used exclusively for laptiming, is allowed.

The addition of a GPS unit for positioning, laptiming and/or lapscoreing purposes or legible messages via an on-board screen is allowed.

Telemetry is not allowed (remote signals to or from the motorcycle), except by compulsory championship devices.

Remote or wireless connections to the motorcycle for any data exchange or setting is not allowed whilst the engine is running or the motorcycle is moving.

The use of bi-directional communication is not allowed except when mentioned in the Supplementary **Regulations** or by the request of the Race Direction and with the approval of the FIM **EWC** Technical Director.

The addition of all Championship contracted devices such as Transponder and Promoter's on-board TV system is allowed. The Promoter is requested to advise the FIM **EWC** Technical Director of the list of motorcycles on which their systems will be fitted in prior of the race.

One extra mechanic (a 5<sup>th</sup> one **identified with a special chasuble given by the Promoter**) will be allowed during the pitstop only to manage these TV devices following the Promoter's instructions.

**Batteries: For safety reasons, whatever is the technology of the battery used, no charging is allowed without any surveillance and during the night (in the pitbox or in the team' truck). The charging area must be safe as possible and as far away as possible of any fuel cans.**

## **2.10 FUEL (PETROL), LUBRICANT AND COOLANTS**

All vehicles must be fuelled with:

- unleaded fuel (from public pump station or race type) OR
- a mixture of unleaded fuels OR
- a mixture of unleaded fuel(s) and lubricant in the case of 2-stroke engines.

The unleaded fuel or the mixture of unleaded fuels used must comply with the FIM specifications as set out in Art. 2.10.1.

The mixture of unleaded fuel(s) and lubricant must comply with the FIM specifications as set out in Art. 2.10.2.

Riders/teams must declare to the FIM Technical Director (or the FMNR Chief Technical Steward when there is no FIM Technical Director appointed) the make and type of fuel to be used during practices and race(s), upon presentation of the rider/team's motorcycle(s) at the initial Technical Verifications. They are also recommended to provide a certificate issued by the fuel company which certify that the fuel has been tested and is in conformity with FIM specifications.

Fuel companies which supply 'race' fuels (fuels other than those obtained at public pump stations) to participating teams/riders must test their fuel at Intertek Schlieren (Switzerland) against FIM specifications set out in Art. 2.10.1 and 2.10.2.

Providing the fuel is within the FIM specifications, a certificate containing a test report and batch number will be issued to the fuel company.

The fuel company shall be able to provide a copy of such certificate to their client rider/teams before they take part in a race.

Contact for fuel analysis: **fimfuels@intertek.com**.

A list of fuels which are in conformity with FIM specifications will be published by FIM on the FIM website.

Furthermore, in the cases in which only fuel from the appointed supplier is permitted (for a specific event or the entire World Championship, Prize or Cup), the aforementioned fuel shall have been previously tested in a FIM appointed laboratory in order to test its conformity with the FIM specifications as set out in Art. 2.10.1 and 2.10.2:

- in case of conformity, a certificate of conformity (including test report and tested batch number) shall be available and Art. 2.10.4 applies in case of controls for the riders/teams;
- in case the conformity is not achieved, the FMN of the organizing country/the Organizer/the Promoter shall ask the FIM for a waiver in order to enable the use of fuel not corresponding to FIM specifications. If the waiver is granted, the riders/teams will be responsible for using the fuel provided without changing its composition. Controls may be carried out by FIM.

### **2.10.1 FIM specifications for unleaded fuels or mixtures of unleaded fuels**

The following specifications are set for unleaded fuel or the mixture of unleaded fuels:

- a) The following properties shall be within the following thresholds (for each property, the relative test methods to be used for the measurement are indicated):

Property	Unit	Min.*	Max.*	Test Method
RON		95.0	102.0	EN ISO 5164 or ASTM D2699
MON		85.0	90.0	EN ISO 5163 or ASTM D2700
Oxygen (includes 10% ethanol allowance)	% (m/m)		3.7	EN ISO 22854 <sup>1</sup> or EN 13132 or elemental analysis
Nitrogen	% (m/m)		0.2	ASTM D 4629 <sup>2</sup> or ASTM 5762
Benzene	% (V/V)		1.0	EN ISO 22854 or ASTM D6839 or ASTM D5580
Vapour pressure (DVPE)	kPa		100.0	EN 13016-1 or ASTM D5191
Lead	mg/L		5.0	ICP-OES or AAS
Manganese	mg/L		2.0	ICP-OES or AAS
Density at 15°C	kg/m <sup>3</sup>	720.0	785.0	EN ISO 12185 or ASTM D4052
Oxidation stability	minutes	360		EN ISO 7536 or ASTM D525
Sulphur	mg/kg		10.0	EN ISO 20846 or ASTM D5453
<b><u>Distillation:</u></b>				EN ISO 3405 or ASTM D86
E at 70°C	% (V/V)	20.0	52.0	
E at 100°C	% (V/V)	46.0	72.0	
E at 150°C	% (V/V)	75.0		
Final Boiling Point	°C		210	
Residue	% (V/V)		2.0	
Appearance	clear, bright and visually free from solid matter and undissolved water			Visual inspection
Olefins	% (V/V)		18.0	EN ISO 22854 or ASTM D6839
Aromatics	% (V/V)		35.0	EN ISO 22854 or ASTM D6839
Total diolefins	% (m/m)		1.0	GC-MS or HPLC
<b><u>Oxygenates:</u></b>				EN ISO 22854 <sup>1</sup> or EN 13132
Methanol	% (V/V)		3.0	The only oxygenates permitted are paraffinic mono-alcohols and paraffinic mono-ethers (of 5 or more
Ethanol (E10)	% (V/V)		10.0	
Isopropanol	% (V/V)		12.0	
Isobutanol	% (V/V)		15.0	
<i>tert</i> -Butanol	% (V/V)		15.0	
Ethers (C5 or higher)	% (V/V)		22.0	

Others	% (V/V)		15.0	carbon atoms per molecule) with a final boiling point below 210°C.
--------	---------	--	------	--

<sup>1</sup> In cases of dispute EN ISO 22854 will be the reference method.

<sup>2</sup> In cases of dispute ASTM D4629 will be the reference method.

\*All reported min. and max. thresholds do not include the tolerance, which needs to be calculated in accordance with ISO 4259 and taken into account to correct the min. and max. thresholds.

- b) The total of individual hydrocarbon components presents at concentrations of less than 5% (m/m) must constitute at least 30% (m/m) of the fuel. The test method will be GC-FID (gas chromatography-flame ionization detector) and/or GC-MS (gas chromatography-mass spectrometry).
- c) The total concentration of naphthene, olefins and aromatics classified by carbon number must not exceed the values given in the following table:

% (m/m)	C4	C5	C6	C7	C8	C9+
Naphthene	0	5	10	10	10	10
Olefins	5	20	20	15	10	10
Aromatics	-	-	1.2	35	35	30

- d) Bicyclic and polycyclic olefins are not permitted. The fuel must contain no substances which are capable of exothermic reaction in absence of external oxygen.

## 2.10.2 FIM specifications for mixtures of unleaded fuel(s) and lubricant

The lubricant :

- must not change the composition of the fuel fraction when added to the fuel;
- must not contain any nitro-compounds, peroxides or any other engine power boosting additives;
- must in no way contribute to an improvement in overall performance;
- during the distillation up to 250°C, must not show a reduction in mass by evaporation of more than 10% (m/m) (test method: simulated distillation GC);
- must contain a max. content of anti-knock agents (lead, manganese, iron) of 10 mg/Kg (test method: ICP-OES).

Moreover, the following specifications are set for the mixture of unleaded fuel(s) and lubricant:

- a) The following properties shall be within the following thresholds (for each property, the relative test methods to be used for the measurement are indicated):

Property	Unit	Min.	Max.	Test Method
RON			102.0*	EN ISO 5164 or ASTM D2699
MON			90.0*	EN ISO 5163 or ASTM D2700
Density at 15°C	kg/m <sup>3</sup>	690**	815**	EN ISO 12185 or ASTM D4052

\*Reported min. and max. thresholds do not include the tolerance, which needs to be calculated in accordance with ISO 4259 and taken into account to correct the min. and max. thresholds.

\*\* Min. and max. thresholds do include the tolerance.

### 2.10.3 Air

Only ambient air may be mixed with the fuel as an oxidant.

### 2.10.4 Sampling and testing

The FIM may require fuel controls, i.e. controls of the unleaded fuel, mixture of unleaded fuels or mixture of unleaded fuel and lubricant, used by riders/teams at events. These controls involve an initial sampling at the event and further testing in the FIM appointed laboratory.

#### 2.10.4.1 Sampling

- 1) The FIM Technical Director (or the FMNR Chief Technical Steward when there is no FIM Technical Director appointed) is the sole official responsible for the sampling management and supervision.
- 2) Riders/teams selected for fuel controls are directed to proceed with their vehicles to the area that has been designated for this purpose.
- 3) The FIM Technical Director/FMNR Chief Technical Steward collects the fuel from the motorcycle by using only new sample containers and pipettes/hand pumps.  
The fuel is transferred through the use of the pipette/hand pump directly from the fuel tank into three containers, denominated A, B and C. The containers are closed and sealed by the FIM Technical Director/FMNR Chief Technical Steward.
- 4) The FIM Technical Director/FMNR Chief Technical Steward fills in (in all its parts) and signs the Fuel Sample Declaration Form (see forms). The rider or a team representative also signs this Form, after verifying that all the information is correct.
- 5) The FIM Technical Director/FMNR Chief Technical Steward prepares an appropriate shipping box containing the collected A, B and C samples and a copy of the respective, signed, Fuel Sample Declaration Form. The box is then shipped to the FIM appointed laboratory by courier.

#### 2.10.4.2 Testing

- 1) One or more properties to be checked (following the relevant testing method as per Art.10.1 and 2.10.2) are set by the FIM for each selected rider/team.
- 2) Sample A is the first sample to be tested by the FIM appointed laboratory.
- 3) Sample B can be used for a second analysis if required by the FIM. The test result of the A or B sample more favourable to the rider/team is taken into account. Costs for the shipping and testing of sample A and B are paid by FIM.
- 4) As soon as possible after completing the testing, the FIM appointed laboratory reports the test results directly to the responsible CTI Coordinator.
- 5) For negative cases (i.e. conformity of the tested property(ies) with the specification), the riders/teams concerned will be individually informed by the FIM in due course, copying the rider/team's FMN, the FIM Technical Director/FMNR Chief Technical Steward, the competent authority (e.g. FIM EWC Stewards Panel, International Jury), the CTI Director, the Director and Coordinator(s) of the sporting Commission concerned.
- 6) Only for positive cases following testing of sample A or B or A and B (i.e. non-conformity of one or more properties\*), the responsible CTI Coordinator notifies by electronic mail\* the rider/team concerned (including the testing results) and, 24 hours after, forwards the relevant information to the rider/team's FMN, the FIM Technical Director/FMNR Chief Technical Steward, the competent authority (e.g. FIM EWC Stewards Panel, International Jury), the CTI Director, the Director and Coordinator(s) of the sporting Commission concerned.  
\*Note: The non-conformity of one property (except the Appearance) is sufficient for declaring non-conformity of the fuel or the mixture.
- 7) If the rider/team wishes to request a counter-expertise, he must notify the responsible CTI Coordinator by electronic mail\* accordingly, within 72 hours of receipt by the FIM of the delivery status notification pertaining to the notification of the test results to the rider/team.
  - If a counter-expertise is requested, the sample dedicated to the counter-expertise is sample C and the test shall aim at checking the same property(ies) previously checked on sample A/B. The rider/team can request that sample C be tested at one of the available FIM appointed laboratories. Costs for shipping and testing of sample C are paid by the rider/team concerned.

Upon notification of the sample C results, the responsible CTI Coordinator notifies by electronic mail\* the rider/team concerned (including the testing results) and forwards the relevant information to the rider/team's FMN, the FIM Technical Director/FMNR Chief Technical Steward, the competent authority (e.g. FIM EWC Stewards Panel, International Jury), the CTI Director, the Director and Coordinator(s) of the sporting Commission concerned.

- If no counter-expertise is requested within the time limit, the responsible CTI Coordinator forwards the relevant information by electronic mail\* the rider/team's FMN, the FIM Technical Director/FMNR Chief Technical Steward), the competent authority (e.g. FIM EWC Stewards Panel, International Jury), the CTI Director, Director and Coordinator(s) of the sporting Commission concerned.
- 8) The competent authority of the event concerned (e.g. FIM EWC Stewards Panel, International Jury) makes a decision based on the information received. The Coordinator of the sporting Commission concerned notifies the rider/team concerned regarding the decision by electronic mail\*.

The non-conformity of :

- A sample (in the cases B sample was not used) or
  - B sample (in the cases A sample result was not conclusive) or
  - A and B samples or
  - A and B and C samples (in the cases B sample was used and a counter-expertise was requested) or
  - A and C samples (in the cases B sample was not used and a counter-expertise was requested)
- automatically results in the disqualification of the rider/team from the entire event.  
No disqualification will be applied in case of conformity of sample C.  
Furthermore, in any case, other penalties may be applied.
- 9) The rider/team has the right to appeal against the decision of competent authority of the event concerned (e.g. FIM EWC Stewards Panel, International Jury) in accordance with FIM Disciplinary and Arbitration Code applicable to the relevant discipline.

\*The receipt of a delivery status notification will be deemed as proof of delivery.

### 2.10.5 Fuel storage

When the fuel is supplied by the Organizer, there must be officially designated and controlled fuel storage areas. Outside these areas, fuel may only be stored in metal containers.

A maximum of 60 litres of fuel stored in a sealable can, is allowed in the competitor's pit box. A quick-fill installation (i.e. fuel tower) for refuelling is allowed.

In all the Classes of the FIM Endurance, fuel used for refuelling must not be below the prevailing ambient temperature.

The FIM Technical Director will confirm in case of doubt.

Other than a simple removable tank cover, the use of any device or method on the motorcycle to artificially decrease the fuel temperature below ambient temperature is forbidden.

The officially designated storage and supply area must be in conformity with the building criteria. Firefighting equipment, protective devices and staff must conform to the requirements imposed by the local authorities and by-laws.

The Organizer must have fire extinguishers of a size and type approved by the local by-laws, available to each competitor in the pit area.

#### **2.10.6 Coolants**

The only liquid engine coolant permitted other than lubricating oil must be water.

### **2.11 PROTECTIVE CLOTHING AND HELMETS**

The rider is at all times responsible for ensuring that his own protective clothing and helmets comply with the FIM Technical Regulations.

**2.11.1** Riders must wear a complete leather suit with additional leather padding or other protection on the principal contact points, knees, elbows, musters, hips that conform to EN1621-1:2012.

The use of sliders (specific parts of the rider's safety equipment, either permanently fixed or removable, intended to make regular contact with the track surface to assist the rider while cornering), is permitted on the knees, elbows or any other parts of the race suit, where it is deemed necessary. They must not be manufactured from or contain any material that when in contact with the track surface may cause visual or other disturbance to other riders.

**2.11.2** Linings or undergarments must not be made of a synthetic material which might melt and cause damage to the riders' skin.

**2.11.3** Riders must also wear leather gloves and boots, which with the suit provides complete coverage from the neck down.

**2.11.4** Leather substitute materials may be used, providing they have been checked by the Chief Technical Steward.

**2.11.5** Use of a chest and back protector is compulsory (with or without airbag protection in the suit) and must be clearly marked with the following norms:  
a) The back protector must comply with EN1621-2, CB ("central back") or FB ("full back") Level 1 or 2.  
b) The chest protector must comply with EN1621-3 **Level 1 or 2**.

Use of a functional airbag system is strongly recommended.

**2.11.6** Riders must wear a helmet which is in good condition, provides a good fit and is properly fastened.

**2.11.7** Helmets must comply with the FIM helmet standard. A list of FIM Homologated helmets is available on [www.frhp.org](http://www.frhp.org).

FIM	FRHPhe-01 (compulsory from 01/01/2020)
FRHPhe-01 (FIM)	

**2.11.8** Visors must be made of a shatterproof material.

**2.11.9** Disposable "tear-offs" are permitted.

**2.11.10** Any question concerning the suitability or condition of the riders clothing and/or helmet shall be decided by the FIM **EWC** Technical Director/ Chief Technical Steward, who may, if he so wishes, consult with the manufacturers of the product before making a final decision.

## **2.12 PROCEDURES FOR TECHNICAL CONTROL**

The team is at all times responsible for its own motorcycle.

**2.12.1** The Chief Technical Steward must be in attendance for an event at least one (1) hour before the technical verifications are due to beginning. He must inform the Clerk of the Course, the Jury President and the **FIM EWC** Technical Director of his arrival.

**2.12.2** The Chief Technical Steward must ensure that all Technical Stewards, appointed for the event, carry out their duties in a proper manner.

**2.12.3** The Chief Technical Steward shall appoint the Technical Stewards to individual posts for the race, practices and final control.

**2.12.4** Technical **I**nspections will only be carried out when the technical specification form of the motorcycle has been distributed by the Organiser (before/during the preliminary controls).

**2.12.5** The **t**eam, represented by the Team **M**anager and up to 2 mechanics, must be present with the motorcycle(s) for Technical **C**ontrol within the time limits stated in the Supplementary Regulations. In addition, each **r**ider must present his own safety equipment (helmets, leathers, boots, gloves, chest and back protector).

**2.12.6** The FIM **EWC** Technical Director/Chief Technical Steward must inform the International Jury of the results of the Technical **C**ontrol. The **FIM EWC** Technical Director/Chief Technical Steward will then draw up a list of accepted motorcycles and submit this list to the Clerk of the Course.

**2.12.7** The FIM **EWC** Technical Director/Chief Technical Steward has the right to inspect any part of the motorcycle at any time of the event.

**2.12.8** Any **t**eam/**r**ider failing to report as required below may be disqualified from the meeting. The International Jury may forbid any team who does not comply with the rules, or any rider who can be a danger to other participants or to spectators, to take part in the practice sessions or in the races.

**2.12.9** The Technical **C**ontrol must be carried out in accordance with the procedure and times fixed in the Supplementary Regulations of the event.

**2.12.10** The FIM **EWC** Technical Director/Chief Technical Steward will refuse any motorcycle that does not have a correctly-positioned positive transponder attachment. The transponder must be fixed to the motorcycle in the position and orientation as shown in the Timekeeping information given to teams pre-season and available at each event. Positive attachment of the transponder bracket consists of a minimum of tie-wraps, but preferably by screw or rivet. Velcro or adhesive alone will not be accepted. The transponder retaining clip must also be secured by a tie-wrap.

**2.12.11** The **t**eam must present a clean motorcycle and in conformity to the FIM **Regulations**. He must also present a duly filled in and confirmed technical card.

**2.12.12** An overall inspection of the motorcycle must be carried out in conformity with the FIM **Regulations**. Accepted motorcycles will be marked with paint or a sticker.

The FIM **EWC** Technical Director/Chief Technical Steward has the final authority in case of a dispute on the conformity of the parts in question and for acceptance thereof.

**2.12.13** The rider is permitted to use whichever motorcycle he chooses from the accepted motorcycles.

**2.12.14** Before each practice the Technical Steward must confirm that the motorcycle has passed the Technical **C**ontrol by checking the Technical **C**ontrol sticker before the motorcycles go on the track.

**2.12.15** Only accepted motorcycles may be used in a race and practice. A change of motorcycle is accepted in accordance with the prescriptions of the sporting appendix.

**2.12.16** Under special circumstances, a team allocated garage “box” may be used for technical checks under the supervision of Technical **S**tewards.

**2.12.17** Approximately 30 minutes after the Technical control has been completed, the FIM **EWC** Technical Director/Chief Technical Steward must submit to the International Jury list of accepted motorcycles and riders in the individual classes.

**2.12.18** If a motorcycle is involved in an accident, the **FIM EWC** Technical Director/Chief Technical Steward must check the motorcycle, together with the helmet and clothing of the rider involved, to ensure that no defect of a serious nature has occurred.

If a motorcycle was stopped with a black flag with orange disc, the FIM **EWC** Technical Director/Chief Technical Steward must check the motorcycle.

In both cases, it is the responsibility of the team to present the motorcycle (together with helmet and clothing of the fallen rider) for this re-examination in case they wish to continue.

If the helmet is clearly defective, the Chief Technical Steward must retain this helmet. The Organiser must send this helmet, together with the accident and medical report (and pictures and video, if available) to the Federation of the rider. If there are head injuries stated in the medical report, the helmet then must be sent to a neutral institute for examination.

**2.12.19** The rider must present his own equipment. The helmet must be marked. Permanent teams may present their equipment for Technical control in their team's pit box.

**2.12.20** The Team may present maximum 2 motorcycles for the initial Technical Verifications.

Due to extraordinary circumstances (i.e. damaged beyond repair) a 3<sup>rd</sup> rolling chassis (assembled with wheels, suspension components and electronics) may be presented for Technical Checks to the FIM **EWC** Technical Director.

**2.12.21** The motorcycle's exhausts/silencer(s) system sound levels should be checked at random choice during practice as well as after the race. On request of rider, team or mechanic, the silencer's sound level of their own motorcycles' may be checked at any time during the event.

**2.12.22** Weight should be checked at the discretion of the FIM **EWC** Technical Director/Chief Technical Steward during practices as well as after the race.

The weight check during practices will be held with minimum disturbance to the riders. The weight scales will be placed in the pit-lane. The actual place is decided by the FIM **EWC** Technical Director/Chief Technical Steward.

On request of rider, team or mechanic, weight and sound of their own motorcycles can be checked at any time during the event.

## **2.13 VERIFICATION GUIDELINES FOR TECHNICAL STEWARDS**

### **2.13.1 Verification**

- Make sure all necessary measures and administrative equipment are in place at least 1 hour before the Technical Control (see separate list) is due to open (time mentioned in the Supplementary Regulations).
- Decide who is doing what and note decisions. "Efficiency" must be the watchword. Always keep cheerful and remember the reasons for Technical Controls: SAFETY AND FAIRNESS.

- Be well informed. Make sure your FMN has supplied you with all technical "updates" that may have been issued subsequent to the printing of the Technical Regulations. Copies of all homologation documents must be in your possession.
- Inspection must take place under cover with a large enough area (min. surface 150 sq. metres) or in front of the pit box of the teams (new procedure).
- A covered "parc fermé" (min. surface 150 sq. metres) must be ready at any time during the race in case of suspension of the race in wet conditions declared by the Race Direction.
- Weighing apparatus must be accurate and practical. Its certificate must be available and dated within 2 years. A set of certified master weights and their certificate must be available for the Technical **C**hecks.
- Rules regarding sound level and measurement must be respected.

All motorcycles will be required for weight and/or sound check at the pre-race technical inspection.

The scales and sound meter will be available to the teams or riders for pre-race checking in the Technical **C**ontrol area.

Sound test must take place in a clear area adjacent to the Technical **C**ontrol at least 5 metres from any possible sound reflecting obstruction.

The riders and teams must be aware that the weight and sound will be controlled at random during practices in the pit-lane, and at the end of each race.

Claiming that the sound and weight were not officially controlled before the race will not be grounds for appeal. Conformity of the rules is the responsibility of the rider and the team.

The FIM **EWC** Technical Director/Chief Technical Steward reserve the right to spot check the weight and sound of any motorcycles on pit row during free practice and official practice. This can occur at any time during the free practice and in the first forty minutes of any official (timed) practice. This will be carried out with the least possible inconvenience to the rider or the team.

Motorcycles arriving later than the first free practice must be controlled in the **T**echnical **C**ontrol area.

At the conclusion of the inspections, a small sticker or coloured mark will be placed on the frame indicating that the motorcycle had passed inspection

The FIM **EWC** Technical Director/Chief Technical Steward must re-inspect any motorcycle that has been involved in an accident.

The Technical Stewards must be available, based on instructions from the FIM **EWC** Technical Director/Chief Technical Steward, to re-inspect any motorcycle for compliance during the meeting.

## 2.13.2 Preparations, procedures

At each circuit, an area must be designated as the Technical control Area. In this area, under the control of the FIM **EWC** Technical Director/Chief Technical Steward, suitable equipment will be available to conduct proper inspections.

The Technical **C**ontrol will be carried out in accordance with the schedule set out in the Supplementary Regulations.

Technical Stewards must be available throughout the entire event to check motorcycles and equipment as required by the FIM **EWC** Technical Director/Chief Technical Steward.

Presentation of a motorcycle will be deemed as an implicit statement of conformity with the **T**echnical **R**egulations.

The Technical Stewards must inspect the motorcycles for obvious safety omissions.

The Technical Stewards must inspect that the motorcycle conforms to all technical rules laid out in the Regulations.

During the **T**echnical **I**nspection in the closed park the mechanics must assist with the inspections. A maximum of four (4) team members per rider is allowed in the closed park during the post-race **T**echnical **I**nspection. Downloading of data is allowed in the closed park.

Representatives of the tyre manufacturers are allowed in the closed park.

### Practice

- **Dry Practice**

Every motorcycle used in free or official practice may be checked.

The minimum checks are weight and sound. The FIM **EWC** Technical Director/Chief Technical Steward may request other checks.

- **Wet practice**

The FIM **EWC** Technical Director/Chief Technical Steward may perform certain checks during/after a wet practice.

### Final inspection at the end of the race

Motorcycles may be checked at least for the following compliance points:

- **Weight:** The weight will be checked in the condition that the motorcycle has finished the race (without the fuel tank and its content). No elements can be added to the motorcycle, neither fuel, oil, water nor tyres.
- **Sound:** compliance with max sound limit

- Carburettors/throttle bodies + injectors:
  - Measurement and inspection of both inlet and outlet tract and injection I homologation points
- Engine: Engine(s), chosen may be checked internally for capacity and compliance with Art. 2.6 (Formula EWC) and Art. 2.7 (Superstock).

The FIM **EWC** Technical Director/Chief Technical Steward may require a team to provide parts or samples, as he may deem necessary to confirm compliance with the rules.

### **Appointment and attendance**

The Technical Stewards must be present and available during all the opening hours of the Technical **C**ontrol area.

The FIM **EWC** Technical Director/Chief Technical Steward will instruct the Technical Stewards to verify motorcycles for compliance with technical and safety rules.

### **Administration day / Technical control:**

For all contracted teams min. 6 persons

Tasks: Inspection of motorcycle safety, clothing and helmets (SOUND AND WEIGHT CONTROL)

For all non-contracted teams: min. 6 persons

The inspection will take place in the **T**echnical **C**ontrol area

Task: Inspection motorcycle safety, clothing and helmets (SOUND AND WEIGHT CONTROL)

Administration tasks: min. 1 person

#### **a) Thursday / Friday:**

Technical **C**ontrol: free practice, qualifying and official qualifying sessions

Task: Inspection of motorcycle safety: **s**ound and **w**eight: min. 12 persons

Inspection of crashed motorcycles and Technical **C**ontrols min. 2 persons

Administration tasks: min. 1 person

#### **b) Saturday / Sunday: Technical **C**ontrol during race day**

##### **Before and after the Warm-Up:**

Task: Inspection of motorcycle safety: **s**ound and **w**eight: min. 12 persons

Inspection of crashed motorcycles and Technical **C**ontrols min. 2 persons

<u>Administration tasks:</u>	min. 1 person
<b><u>Before race:</u></b> safety checks on start grid:	min. 4 persons
<b><u>During the race:</u></b> random inspections:	min. 8 persons
<u>After race:</u> Technical <b>C</b> ontrol sound weight and carburation instruments	min. 8 persons
<u>Displacement checks</u>	min. 2 persons
<u>Administration tasks</u>	min. 1 person

**NOTE:** This is the required minimum of Technical Stewards. The number may of course be higher.

All final verification points to be decided in co-operation with the International Jury President and the FIM **EWC** Technical Director/Chief Technical Steward. Post-race checks are under extreme pressure. It is important to be very well organised.

Chief Technical Steward must report to the Jury after the verifications.

### **Minimum Equipment list**

- Revolution meter
- Sound meter and calibrator
- Slide caliper
- Depth gauge
- Steel measuring tape
- Seals
- Weighing apparatus (scales) with calibration weights
- Tools for measuring engine capacity
- Tools for measuring valve lift
- Weighing apparatus for investigation of valve weights
- Colour for marking parts
- Magnet for materials testing
- Computer to read homologation CD-Rom
- **Tools for measuring fuel tank capacity**
- **Various stickers or paint markers to marks parts (silencers, engine, etc.)**
- **Tools for measuring temperature of surface (temperature laser gun)**

### **Documents list**

- Regulations of the CURRENT YEAR
- Supplementary Regulations
- Homologation documents
- CD-Rom with homologations
- Technical control forms
- Writing materials



## FIM ENDURANCE WORLD CHAMPIONSHIP MACHINE INSPECTION - DECLARATION FORM

**General info and Section 1** must be completed by the TEAM and handed over to the Chief Technical Steward.

<b>FIM - EWC TECHNICAL CONTROL FORM</b>		IMN N°:
EVENT		PLACE :
TEAM (NAME)		CAT :
NATIONALITY		<b>N°</b>
LIC. TEAM N°		
<b>SECTION 1 - MOTORCYCLE INFORMATION</b>		
	<b>MOTORCYCLE 1</b>	<b>MOTORCYCLE 2 (T)</b>
MANUFACTURER		
COMMERCIAL MODEL		
YEAR		
FRAME NUMBER		
ENGINE NUMBER (FOR TECHNICAL INSPECTIONS)		
ENGINE NUMBER (FOR RACE IF ENGINE CHANGE)		
BALLAST ON-BOARD (KG) + LOCATION		
ELECTRONIC CONTROL SYSTEM - MANUFACTURER		
ECU SERIAL N° (FOR SUPERSTOCK)		
<b>SECTION 2 - ENGINE ON/OFF - LIGHTS</b>		
ENGINE CUT- OFF SWITCH (ONLY RED)		
HEADLIGHTS (2) - REAR LIGHTS (2)		
3RD REAR EMERGENCY LIGHT - SEPARATE ON/OFF SWITCH		
ELECTROLUMINESCENT NUMBER PLATES (FRONT/REAR)		
<b>SECTION 3 - SAFETY</b>		
THROTTLE GRIP/SELF CLOSING		
FREE STEERING ROTATION		
BRAKES - CORRECT WORKING FR/RR + FR BRAKE LEVER PROTECTOR		
HANDLEBARS + FOOTRESTS END CAPS R/L		
BOTTOM FAIRING CLOSED + BRACKETS R/L		

OIL DRAIN/FILLER PLUGS, OIL FILTER, ETC. WIRED		
ONLY WATER IN RADIATOR		
CRANKCASE PROTECTIVE COVER R/L (3 FIXING POINTS)		
<b>SECTION 4 - FUEL EQUIPMENT</b>		
FUEL TANK WITH FIXED MOUNTING POINTS (MIN. 3)		
QUICK FILL FUEL VALVE - MANUFACTURER /DIAMETER/RESTRICTOR (FIM CTI SEAL)		
FUEL VALVE LOCKING SYSTEM OR PROTECTIVE COVER		
FUEL CATCH TANK		
FUEL CHARGER (LEAKPROOF, HEIGHT MAX. 120MM)		
REFUELLER(S) EQUIPMENTS (FIRE RETARDANT SUIT, GLOVES, BALACLAVA, GLASSES, HELMET, CLOSED SHOES)		
<b>SECTION 5 - SOUND/WEIGHT</b>		
SOUND LEVEL (DB)		
WEIGHT (KG)		
<b>SECTION 6 - FIM STICKER</b>		
<b>REMARKS :</b>		
<p>Acceptance of a motorcycle for competition does not preclude the possibility of further controls to ensure compliance with the competition Technical rules.</p>		
<b>TECHNICAL STEWARD :</b> <b>DATE :</b>	<b>TEAM MANAGER :</b> <b>PHONE N° : +</b> <b>EMAIL :</b>	
<b>SIGNATURE :</b>	<b>SIGNATURE :</b> I hereby declare that the information given above is accurate in every respect.	



## FIM WORLD CHAMPIONSHIPS and PRIZE EVENTS Fuel Sample Declaration Form

**Discipline:** ..... / **Venue:** .....  
 ..... / **Date:** .....

<b>Samples taken during/after:</b>  FP / QP / or Race N°:                      Time :	<b>Sample "A"</b>	
	Container N°	Seal N°
<b>Rider/Team's responsible name:</b>	<b>Sample "B"</b>	
	Container N°	Seal N°
<b>Rider/Team's number:</b>	<b>Sample "C"</b>	
	Container N°	Seal N°

**Vehicle make :**                                      **Model :**

**Fuel make :**                                      **Type :**                                      **Batch N°**

**Fuel origin (public station)**                                      **Race fuel origin:**

**Sample taken**                                      **(dd/mm/yy)**

The above listed details refer to fuel samples taken from the fuel tank of the motorcycle.

- Sample A is the first testing sample to be used by the FIM appointed laboratory.
- Sample B can be used for a second analysis if required by the FIM.
- Sample C is used if a counter-expertise is required by the rider/team.

The serial numbers of the vial seals and the accuracy of the information have been verified.

**Information:**  
 Rider/Team's - Telephone number/E-mail : .....  
 Rider/Team's Representative's Signature: .....

FIM Technical Director/ or FMNR Chief Technical Steward name:  
 .....

FIM Technical Director/ or FMNR Chief Technical Steward signature:  
 .....

## 2.14 SOUND CONTROL

### Sound limits in force

Sound will be controlled to:

Max. 105 dB/A measured at a mean piston speed of 11 m/sec.  
(The fixed RPM specified in Art. 2.14.6 may be used.)

**No modification (by any possible way) of the original RPM channel is allowed. The RPM information displayed on the dashboard and shown by the team must be the real engine revolution. Furthermore, all systems as “home-made” dB-Killers (not delivered as original part or accessory of the silencer / exhaust line) are strictly forbidden. All these cheating systems will be strongly penalized.**

**2.14.1** With the microphone placed at 50 cm from the exhaust pipe at an angle of 45° measured from the centre-line of the exhaust end and at the height of the exhaust pipe, but at least 20 cm above the ground. If this is not possible, the measurement can be taken at 45° upwards.

**2.14.2** During a sound test, motorcycles not equipped with a gear box neutral must be placed on a stand.

**2.14.3** The silencers will be marked when they are checked and it is not allowed to change them after the verification, except for any spare silencer which has also been checked and marked.

**2.14.4** The rider / **mechanic or the FIM/FMN technical steward (holder of a valid FIM technical licence)** shall keep his engine running out of gear and shall increase **smoothly** the engine speed until it reaches the specified Revolutions Per Minute (RPM). Measurements must be taken when the specified RPM is reached.

**2.14.5** The RPM depends upon the mean piston speed corresponding to the stroke of the engine.

The RPM will be given by the relationship:

$$N = \frac{30,000 \times cm}{l}$$

in which      N            = prescribed RPM of engine  
                  cm            = fixed mean piston speed in m/s  
                  l             = stroke in mm

### 2.14.6 Sound control

Due to the similarity of the piston stroke in different engine configurations within the capacity classes, the sound test will be conducted at a fixed RPM. For reference only, the mean piston speed at which the sound test is conducted, is calculated at 11 m/sec.

	2 cylinders	3 cylinders	4 cylinders
Up to 750 cc	5,500 RPM	6,000 RPM	7,000 RPM

Over 750 cc	6,000 RPM	6,000 RPM	6,000 RPM
-------------	-----------	-----------	-----------

**2.14.7** The sound level for engines with more than one cylinder will be measured on each exhaust end.

**2.14.8** A motorcycle which does not comply with the sound limits may be presented several times at pre-race control.

**2.14.9** The surrounding sound should not exceed 90 dB/A within a 5 metres radius from the power source during tests.

**2.14.10** Apparatus for sound control must be to international standard IEC 651, Preference: Type 1. As alternative, a Type 2 is permitted.

The sound level meter must be equipped with a calibrator for control and adjustment of the meter during periods of use. These instruments must have been calibrated by an approved testing Laboratory, the latest one year before the date of the event.

**2.14.11** The "slow response" setting must always be used.

#### **2.14.12 Sound control after the competition**

In a competition which requires a final examination of motorcycles before the results are announced, this examination must include a sound control measurement of at least the first three motorcycles listed in the final classification of each class and/or category. At this final test, there will be a 4 dB/A tolerance.

#### **2.14.13 Sound control during a competition**

In a competition which requires sound control tests during the event, motorcycles must comply with the sound limits without the tolerance in Art. 2.14.

### **2.15 GUIDELINES FOR USE OF SOUND LEVEL METERS**

**2.15.1** The Sound Control Officer (NCO) must arrive in sufficient time for discussions with the **FIM EWC** Technical Director and other Technical Stewards in order that a suitable test site and testing policy can be agreed.

**2.15.2** Sound level measuring equipment must include a compatible calibrator, which must be used immediately before testing begins and always just prior to a re-test if a disciplinary sanction may be imposed.

Two sets of equipment must be available in case of failure of tachometer, sound level meter or calibrator during **Technical Control**.

**2.15.3** Before testing, the NCO must calibrate the sound test equipment with a calibrator, in order check the accuracy of the official sound meter.

**2.15.4** Tests can take place in rain or damp conditions. Motorcycles considered excessively noisy must be individually tested if conditions allow.

**2.15.5** In other than moderate wind, motorcycles should face forward in the wind direction. (Mechanical sound will blow forward, away from microphone).

**2.15.6** 'Slow' meter response must be used.

**2.15.7** 'A' weighted setting on sound level meter.

**2.15.8** No rounding down of the meter reading: 107.9 dB/A = 107.9 dB/A.

**2.15.9** **Correction**

Type 1 or 2 meter : Precision of the method: allow + 2 dB/A

**The use of a Type 1 meter is preferred.** All tolerances are accumulative. Action and decisions will be taken after discussions with the FIM **EWC** Technical Director/Chief Technical Steward.

---