



FÉDÉRATION INTERNATIONALE
DE MOTOCYCLISME

**TECHNICAL RULES
TRACK RACING**

2022

Technical Rules Track Racing

2022

Règlements Techniques Courses sur Pistes

Version **3**
Applicable as from **23.05.2022**

YEAR 2022		
Version	Applicable as from	Modified paragraphs
0	01.01.2022	01.55, 01.56, 47.02, 65.01
1	01.01.2022	01.63 Methanol, Gasoline and Lubricant > FIM Fuels Regulation_TRACK RACING 2022
2	01.01.2022	01.79 Sound Level Control > FIM Sound Regulation_TRACK RACING 2022
3	23.05.2022	25.04, 31.03.7

Table of contents

01.01	INTRODUCTION	5
01.03	FREEDOM OF CONSTRUCTION	5
01.05	CATEGORY AND GROUPS	5
01.07	CLASSES	6
01.11	MEASUREMENT OF CAPACITY	6
01.17	SUPERCHARGING	7
01.18	TELEMETRY	7
01.19	MOTORCYCLE WEIGHTS.....	8
01.21	DESIGNATION OF MAKE.....	8
01.23	DEFINITION OF A PROTOTYPE.....	9
01.25	GENERAL SPECIFICATIONS.....	9
01.26	DEFINITION OF A FRAME OF A SOLO MOTORCYCLE	10
01.27	STARTING DEVICES.....	10
01.29	OPEN TRANSMISSION GUARDS.....	10
01.31	EXHAUST PIPES AND SILENCERS	11
01.33	HANDLEBARS	15
01.35	CONTROL LEVERS.....	16
01.37	THROTTLE CONTROLS.....	16
01.38	REV LIMITER.....	17
01.39	FOOTRESTS.....	17
01.41	BRAKES.....	18
01.43	MUDGUARDS AND WHEEL PROTECTION	18
01.45	STREAMLINING.....	19
01.46	INCLINATION AND SUSPENSION OF MOTORCYCLES	20
01.47	WHEELS, RIMS AND TYRES (See Table 01.86)	20
01.49	TYRES FOR 250cc/500cc SPEEDWAY AND SPEEDWAY	20
01.50	TYRES FOR 250cc/500cc LONG TRACK.....	22
01.51	TYRES FOR ICE RACING	22
01.52	WHEELS, RIMS AND TYRES FOR TRACK RACING SIDECARS	23
01.53	ADDITIONAL SPECIFICATIONS FOR 500cc SIDECARS.....	24
01.54	ADDITIONAL RULES FOR 1000CC SPEEDWAY SIDECARS.....	27
01.55	NUMBER PLATES	30
01.56	OIL CATCH TANKS	33
01.57	ENVIRONMENTAL MAT	33
01.58	SPECIFICATION FOR TRACK RACING MOTORCYCLES.....	33
01.59	SPECIFICATION FOR ICE RACING MOTORCYCLES	35
01.65	EQUIPMENT AND PROTECTIVE CLOTHING DURING PRACTICE AND RACE	36
01.67	WEARING OF HELMETS.....	37
01.68	HELMET COLOUR.....	37
01.69	HELMET OPERATIVE INSTRUCTIONS.....	38
01.70	RECOGNISED INTERNATIONAL HELMET APPROVAL MARKS	39
01.75	BADGE OF THE FIM.....	40
01.76	SCRUTINEERING.....	40
01.77	TECHNICAL VERIFICATIONS.....	40
01.78	DANGEROUS MACHINES.....	46
01.83	ADDITIONAL RULES FOR 85 CC SPEEDWAY MOTORCYCLES.....	47

01.84	TECHNICAL SPECIFICATIONS FOR 125 CC TRACK RACING MOTORCYCLES.....	49
01.86	FIM HOMOLOGATED REAR TYRES	51

DIAGRAMS

Any references to the male gender in this document are made solely for the purpose of simplicity, and refer also to the female gender except when the context requires otherwise.

01.01 INTRODUCTION

The term motorcycle covers all vehicles having, in principle, less than four wheels, propelled by an engine and designed essentially for the carriage of one or more persons of which one is the rider of the vehicle. The wheels must normally be in contact with the ground except momentarily or in certain exceptional circumstances. Furthermore, in order to traverse certain surfaces one or all of the wheels can be replaced with skis, rollers or chains.

01.03 FREEDOM OF CONSTRUCTION

A motorcycle must conform to the requirements of the FIM regulations, to the Supplementary Regulations, as well as to a number of specific conditions that the FIM may require for certain competitions. No restriction is placed on the make, construction or type of motorcycle used.

All solo motorcycles (Group A) must be constructed in such a way that they are entirely controlled by a rider. Motorcycles with Sidecars (Group B) must be constructed to carry a passenger.

01.05 CATEGORY AND GROUPS

Motorcycles are divided into categories which must be observed for all meetings and world record attempts.

In principle, it is forbidden for different categories, groups and classes to compete in the same race, unless the Supplementary Regulations state otherwise.

Category I

Motorcycles propelled by the action of one wheel in contact with the ground. The other categories are not applicable to Track Racing.

Group A1 - Solo Motorcycles

2-wheel vehicles making only one track on the ground.

Group B1

Vehicles with three wheels, making two tracks on the ground, consisting of a motorcycle making one track and a Sidecar for a passenger making the other.

Group B2

Vehicles with three wheels, making two or three tracks on the ground in the direction of forward travel, with a permanently attached Sidecar forming a complete integral unit.

If three tracks are made, the centre-lines of the two tracks made by the motorcycle wheels must not be more than 75 mm apart. A track is determined by the longitudinal centre-line of each of the vehicle's wheels in the direction of forward travel.

01.07 CLASSES

Groups are again separated into classes according to cylinder capacities as detailed below. These classes must be observed for all meetings.

Category I

Group A1 - Solo Motorcycles

Class	Over (cc)	Up to (cc)
85	50	85
125	100	125
250	175	250
500	350	500
1000	750	1000

For Classic Speedway, Long Track and Ice Racing:

- 250cc Class: Up to 250cc 4 stroke single cylinder engines
- 500cc Class: Up to 500cc 4 stroke single cylinder engines

Groups B1, B2 - Sidecars

Same as groups A1 and A2 over 175 cc.

01.11 MEASUREMENT OF CAPACITY

11.11 Reciprocating movement engine, "Otto" Cycle

The capacity of each engine cylinder is calculated by the geometric formula which gives the volume of a cylinder; the diameter is represented by the bore, and the height by the space swept by the piston from its highest to lowest point:

$$\text{Capacity} = \frac{D^2 \times 3.1416 \times C}{4}$$

where D = bore
and C = stroke

When a cylinder bore is not circular the cross sectional area must be determined by a suitable geometrical method or calculation, then multiplied by the stroke to determine capacity.

When measuring, a tolerance of 1/10 mm is permitted in the bore. If with this tolerance the capacity limit is exceeded for the class in question, a further measurement should be taken with the engine cold, to 1/100 mm limits.

11.13 Rotary engines

The capacity of an engine which determines the class in which the motorcycle shall compete in a meeting shall be calculated by:

$$\text{Capacity} = \frac{2 \times V}{N}$$

where V = total capacity of all the chambers comprising the engine

and N = number of turns of the motor necessary to complete one cycle in a chamber

Classified as a 4-stroke.

11.15 Wankel system

For Wankel system engines with a triangular piston, the capacity is given by the formula:

$$\text{Capacity} = 2 \times V \times D$$

where V = capacity of a single chamber

and D = number of rotors

This engine is classified as a 4-stroke.

01.17 SUPERCHARGING

Supercharging by means of a device of any kind is forbidden in all meetings.

An engine, whether 2-stroke or 4-stroke, coming within any one of the recognised classes (determined by the capacity of the working cylinder) shall not be considered as supercharged when in respect of one engine cycle, the total capacity measured geometrically of the fuel charging device or devices, including the capacity of the working cylinder (if used for injecting the fuel), does not exceed the maximum capacity of the class in question.

01.18 TELEMETRY

Information must not be transmitted in any way to or from a moving motorcycle.

An official signalling device may be required on the machine.
Automatic lap timing devices are not considered as “telemetry”.
Automatic lap timing devices must not disrupt any official time keeping methods and equipment.

01.19 MOTORCYCLE WEIGHTS

The motorcycles need to be presented with an empty fuel tank.
The minimum weights (without rider and/or passenger, with all operational fluids) for motorcycles are:

For 85cc Speedway	55 kg
For 250cc Speedway	75 kg
For 500cc Speedway	77 kg
For 125cc Track Racing	60 kg
For 250cc Long Track	80 kg
For 500cc Long Track	82 kg
For Ice Racing	110 kg
For 500cc Track Racing Sidecars	115 kg
For 1000cc Speedway Sidecars	180 kg

These are absolute limits and no tolerance is applied when the machine is checked before the practice/qualifying race/race.

The minimum weight of the verified motorcycle must not at any time be less than the minimum weight required.

A scale with a minimum resolution of 500g must be used (although 100g is recommended).

During the competition, motorcycles are weighed in the condition they leave the track after every heat (including the fuel).

19.01

A 1 % tolerance in the weight of the machine when checked during or after the race, in order to take into account the variability of the test conditions.

19.03

Seals must be fixed to the front of the main frame.

19.05

For Groups B1 and B2: a passenger must be carried at all competitions.

01.21 DESIGNATION OF MAKE

When two manufacturers are involved in the construction of a motorcycle the name of both must appear on the machine as follows:

- The name of the chassis manufacturer
- The name of the engine manufacturer

01.23 DEFINITION OF A PROTOTYPE

A prototype motorcycle is a vehicle which must conform to the safety requirements as required by the FIM Sporting Code and Appendices applicable to the type of competition for which it is to be used.

01.25 GENERAL SPECIFICATIONS

The following specifications apply to all vehicles of the groups indicated and to all types of competitions except where otherwise stated in the corresponding section of the FIM Sporting Code.

They should also be applied to all national competitions unless the FMNR (National Motorcycling Federation) has otherwise directed.

Further specifications for some competitions may also be required and these will be detailed in either the appropriate **FIM track racing Appendices** or in the Supplementary Regulations for the competition in question.

Concerning material verification, in case of doubt, a sample or the part in question shall be taken and analysed at a Material Testing laboratory.

25.01 Use of titanium and light alloys

The use of titanium in the construction of the frame, the front forks, the handlebars, the swing-arm and swing-arm spindle, and front and rear wheel spindles is forbidden.

The use of light alloys for wheel spindles is also forbidden.

The use of titanium alloy nuts and bolts is allowed.

25.03 Carbon fibre

The use of carbon fibre reinforced materials is authorised (with the exception of handlebars and wheel rims).

25.04 Ceramic materials

The use of ceramic parts is forbidden (except for clutch disk **and clutch bearing**)

25.05 Other equipment

The use of data recording devices and automatic electronic ignition is authorised. The use of any components or switches to enable a rider modify the ignition settings physically or manually during the race is forbidden.

No signal of any kind may pass between a moving motorcycle and any person, including radio and Bluetooth communication. The exception is for the signal from the time keeping transponder, automatic lap timing devices or from the authorized on-board cameras (with prior written approval from the Championship Promoter/FIM Officials, which cannot be granted for helmet mounted cameras).

25.06 Number of cylinders

For all races (with the exception of 1000cc **Speedway** Sidecars), only single cylinder engines are allowed.

25.07

If separate combustion spaces are used they must be connected by an unrestricted passage of minimum cross sectional area at least 50 % of the total inlet port area.

25.08

Carburettors only can be used. Any electronic tuning devices are forbidden.

01.26 DEFINITION OF A FRAME OF A SOLO MOTORCYCLE

The structure or structures used to join any steering mechanism at the front of the machine to the engine/gear box unit and to all components of the rear suspension.

01.27 STARTING DEVICES

Starting devices for the engine are not compulsory.

01.29 OPEN TRANSMISSION GUARDS

29.01

The primary transmission must have a proper guard as a safety measure; small holes (max 10mm) in the transmission/clutch guard are allowed for extra cooling.

Excessive cutting of the guard is not allowed. Cutting of the guard is only permitted to expose the clutch pressure plate and to allow adjustments to the clutch springs.

The guard must be conceived in such a way that under no circumstances the rider or the passenger can come accidentally in contact with the transmission/clutch parts. It must be designed to protect the rider from injuring his fingers.

An additional protective device must be provided to prevent a broken primary chain from flying upwards. This can be provided by either a fully enclosed steel chain guard. Alternatively, if a chain guard is made from plastic or from other material, then a steel bolt of 10 mm minimum diameter must be placed outside the bottom rear quadrant of the clutch sprocket (see Diagrams G/H/K). This bolt, if damaged, must always be completely replaced.

A guard/cover must be fitted to the countershaft sprocket (if it is exposed).

29.03

A protective guard must be fitted where the rear chain enters onto the rear wheel sprocket.

01.31 EXHAUST PIPES AND SILENCERS

Exhaust pipes and silencers must fulfil all the requirements concerning sound-level control.

Exhaust fumes must be discharged towards the rear but not in a manner as to raise dust, foul the tyres or brakes, or inconvenience the passenger (in case of sidecars), or any other rider.

As of 01.01.2015, FIM announced the following new construction requirements for silencers in Track Racing (for all 500cc and 250cc single cylinder engines running on methanol including Ice Racing, except for 85cc and 125cc).

- All silencers used must be homologated by the FIM.
- The FIM silencer homologation consists of several sound tests. Every sound test will be made by using a conventional exhaust pipe and a modified exhaust pipe (see description in Nr 1). Sound tests will be made with the FIM nominated official.

1. Exhaust pipe:

A single main exhaust pipe is prescribed with an external diameter of maximum 50 mm for 500cc motorcycles and 40 mm for 250cc motorcycles. An exhaust pipe may include external or internal sound suppression body (max diameter 50 mm or 40 mm for 500cc and 250cc motorcycles respectively/max length 250 mm) to reduce the sound level, welded securely on top and parallel to the exhaust pipe. Material is free. (Requirements to fix the exhaust pipe remain the unchanged.)

2. Silencer construction:

The silencer must be made as one complete, sealed unit without any removable parts. The silencer must be a mechanical type, using the position of permanently fixed pipes, baffles or plates to reduce the sound to the maximum permitted sound level.

Insulating material, for the sole purpose of reducing the external temperature of the silencer body, is permitted provided it is contained within a sealed chamber that has no contact with exhaust gas or the outside atmosphere.

The end of the silencer exhaust pipe, when fitted on the motorcycle, must be parallel to the central axis of the machine (tolerance 10°). The maximum length is 20 mm (including a rounded collar); the maximum internal diameter of the pipe exit is 45 mm (+ 2.0 mm tolerance). The end of the silencer must finish at a right angle and contain a rounded collar (min. 5mm/max. 10 mm).

Fixing points to attach a heat shield may be included.

3. Silencer length and location:

The position of the silencer is provided by the following limitations: the silencer/exhaust system shall not exceed the leading edge of the rear wheel when viewed from the side and leave space for the riders' foot. The silencer exit is behind the rider and within the rear tyre silhouette of the motorcycle when viewed from the side.

4. Maximum permitted sound level: 115 dB/A

All new silencer presented for approval shall not exceed the maximum permitted sound level of 115 dB/A.

The values already take into account the accuracy of the method.

No deductions for ambient temperature, pressure or altitude are allowed.

Sound tests will be performed using the '2 meter max' method (see Art.01.79).

5. Engine RPM:

All silencers presented for homologation will be tested with an engine RPM level of 11.000 rpm to measure the sound limit produced by the combination of the exhaust and silencer.

6. Period of validity:

The use of FIM homologated silencer is mandatory.

MANUFACTURER	PRODUCT IDENTIFICATION	VALID FROM
DEP FREEFLOW	FIM 26AY15	01.01.2015
KING 2015	FIM 071Y15	01.01.2015
POLDEM2	FIM 06BP78	01.01.2015
REMUS V4	FIM 10CT15	01.01.2016
REMUS V7	FIM 11V15	01.01.2016

Any new FIM homologated silencer shall be constructed according to these requirements and be within the maximum permitted sound level. A homologation fee will be applied.

31.01 FIM homologated silencers

Since 2020, it is compulsory to mark the year of production on the silencer.

Only homologated silencers with their year of production stamped will be accepted for Solo Motorcycles and Sidecars belonging to 250cc and 500cc Speedway, Ice Racing and Long Track.

Modifying the homologated silencer is not permitted on 250cc & 500cc Track Racing motorcycles. The only modification allowed to fit homologated silencers for use on 250cc Track Racing motorcycles, is by the use of an adapter between the end of the exhaust pipe and the inlet pipe of the silencer.

Since 2020, it is compulsory to change the homologated silencer every 4 years, except for Ice Racing where the validity is 5 years.

31.03 Construction requirements

The silencer must be made as one complete, sealed unit, without any removable parts.

31.03.1 The exhaust pipe must be fixed to the cylinder head and frame with a minimum of 3 clips (the point of fixture at the cylinder head is considered as one clip). The silencer must be fixed to the frame with at least one clip.

Additionally, a second flexible coupling must be fitted from the first third of the silencer to the frame. This second coupling should be a steel cable of at least 3 mm \varnothing or strong steel spring.

31.03.2 The outside diameter of the single exhaust pipe must not exceed 50mm and 40 mm for 500cc and 250cc motorcycles respectively and must be constant, in principle, over its entire length. However, the end of the exhaust pipe can be swaged out to fit into the silencer (max. diameter 50 mm).

The exhaust pipe may include a sound suppression system (with a max diameter 50 mm or 40 mm for 500cc and 250cc motorcycles respectively/max length 250 mm), may be added, welded securely on top and parallel to the exhaust pipe.

31.03.3 The outlet area of the silencer must remain constant over a length of 50mm and must not exceed 45mm internal diameter or an equivalent area and must not be perforated (no slots, holes, etc.).

31.03.4 The end of the exhaust pipe, over a minimum distance of 30mm, must be horizontal and parallel to the central axis of the solo machine (with a tolerance of $\pm 10^\circ$).

31.03.5 The end of the pipe must be cut at a right angle. The end of the silencer must be cut at a right angle. The silencer end must be a rounded edge with a diameter of 5mm minimum. See Diagrams G, H, K and P.

31.03.6 Between the silencer and the tyre a maximum gap of 60mm (90mm for Ice Racing), with a tolerance of +/- 10mm), must not be exceeded (see Diagram P).

31.03.7 It is compulsory that all homologated silencers be fitted with a heat shield (guard) **declared eligible for competition** by the FIM, securely mounted on the exterior of the silencer, to give extra protection to riders in the event of close contact (In Ice Racing, the heatshield is recommended).

All FIM homologated silencers (starting with the 2015 models) shall be equipped with a heat shield (guard), provided by the manufacturer of the silencer or their supplier.

MANUFACTURER	PRODUCT IDENTIFICATION	VALID FROM
Astromal AS-Speedway	SC-03	01.01.2015
Astromal AS-Speedway	SC-04	01.01.2015
Astromal AS-Speedway (S)	SC-05	01.01.2016
Astromal AS-Speedway	SC-06	01.01.2016
DEP (by Pro Carbon)	SPA02	01.01.2015
DEP (by Pro Carbon)	SPA 09	01.01.2015
DEP (by GPM)	SPA 10	01.01.2015
FRP (By Foxy Racing Products)		01.01.2013
GPM (by gpmouldings.co.uk)		01.01.2015
GPM (by gpmouldings.co.uk)		01.01.2015
Jack Attack	2015 POL	01.01.2015
Jack Attack	2015	01.01.2015
JOBA Tri Oval Apache	2014	01.01.2014
JOBA Tri Oval Apache	2015	01.01.2015
KL Support Aps	KJL	23.05.2022
REMUS Sportexhaust		01.01.2016
SRP (by Speiser)	2013	01.01.2013

31.04

The exhaust system must not extend beyond the vertical line drawn at the end of the rear tyre.

31.05

On a Sidecar motorcycle, the exhaust must discharge horizontally and towards the rear, at a maximum angle of 30° to the axis of the machine, and at the end must be of constant diameter over a distance of 30mm.

31.06

If any part of the motorcycle's exhaust system during racing or practice becomes displaced, detached or damaged or fails in any other way so that all the exhaust gases do not pass through the silencer in a proper manner, the Rider concerned will be immediately disqualified from the heat or from the practice run.

01.33 HANDLEBARS

33.01

The width of handlebars is:

85/125 cc:	Not less than 650 mm and not more than 850 mm.
250cc/500 cc Track Racing:	Not less than 700 mm and not more than 900 mm.
Ice Racing:	Minimum: 700 mm, maximum width: 800 mm.
All other:	Not less than 700 mm and not more than 900 mm.

33.02

The handlebars must be equipped with a protection pad on the cross bar. The handlebars without cross member must be equipped with a protection pad located in the middle of the handlebars, covering widely the handlebars clamps.

33.03

Handlebar clamps must be very carefully radiused and engineered so as to avoid any fracture points in the handlebar.

33.04

Exposed handlebar ends must be plugged with a solid material or rubber covered.

33.06

When hand protectors are used, these must be made of a shatter-resistant material and have a permanent opening for the hand.

33.07

Handlebars made of composite materials are not authorised.

33.08

Repair by welding of light alloy handlebars is prohibited.

33.09

Solid stops (when on full-lock, other than steering dampers) must be fitted. A steering damper cannot be used as a steering lock.

33.10

For Ice racing, the extremity of the left handlebar must be fitted with an integral steel ball of at least 28 mm in diameter. Clip-on handlebars consisting of two separate parts are forbidden.

33.11

For Track racing Sidecars, the minimum angle of rotation of the handlebar on each side of the centre line or mid position must be at least 40°. The steering must be effected only through the motorcycle front wheel and its steering fork. A steerable sidecar wheel is forbidden.

01.35 CONTROL LEVERS

35.01

All handlebar levers (clutch, etc.) must be in principle ball ended (diameter of this ball to be at least 16 mm). This ball can also be flattened, but in any case the edges must be rounded (minimum thickness of this flattened part 14 mm). These ends must be permanently fixed and form an integral part of the lever. If the gear lever consists of a tube, then its edge must be rounded.

35.03

Each control lever (hand and foot levers) must be mounted on an independent pivot.

35.03.1 For Ice racing, a stop must provide a minimum clearance of 15 mm between the left hand control lever and the handlebar grip.

35.03.2 Gear and clutch levers must be positioned in such a manner that the rider does not need to change his position to operate them.

35.03.3 The lever must be mounted to swivel, so that at no time can the rider's fingers be trapped between the lever and the handlebars.

35.03.4 The end of levers when closed must not be situated wider than the furthest extremity of the handlebar. For Ice Racing, the end of the levers shall not exceed the end of the handlebars.

35.04

The brake lever if pivoted on the footrest axis must work under all circumstances, such as the footrest being bent or deformed.

01.37 THROTTLE CONTROLS

37.01

Throttle controls must be self-closing when not held by the hand. The throttle operation (opening and closing) shall only be activated by mechanical cable from the twist grip directly attached to the throttle valve. Electronically controlled throttle valves are forbidden. All air intakes into the cylinder must pass through the throttle body. No other means allowing ambient air into the inlet track of the cylinder head are allowed.

37.02 Ignition cut-out switches

Solo and sidecar motorcycles must be equipped with a functional ignition kill switch or button mounted on either right or left side of handlebar (within reach of the hand while on the hand grips) that stops a running engine. The ignition cut-out switch may also be fitted on the handlebar, as close as practicable to the throttle.

The lanyard must remain attached to the wrist of the rider, mechanic or support team member at all times **when the engine is running.**

The ignition cut-out must stop the engine immediately, by the simple action of pulling a lanyard or a non-elastic string (which must be as short as possible) attached to the rider's right wrist.

All other engine management switches and electrical connectors must remain covered or closed during riding.

01.38 REV LIMITER

All 250cc engines shall incorporate an ignition system with rev limiter. Such rev limiters must remain unmodified as delivered by the manufacturer.

The rev limiter is also compulsory for all 500cc – 4 valve speedway engines used in solo machines (announced in 2019). The hard rev-limit must be set to 13,500 rpm. A soft limiter is recommended before the hard limiter. The FIM allows a 300 rpm tolerance based on the hard rev-limit of 13,500 rpm.

01.39 FOOTRESTS

39.01

Footrests of motorcycles for Ice racing and all types of Solo Track racing shall be on the right-hand side of the machine and must not exceed 320 mm in length measured from the centre line of the motorcycle (see Diagrams G, H and K).

39.03

For Track Racing Sidecars, the footrest on the opposite side to the Sidecar must be protected at the front by a crash bar connected to the frame, so that injury or damage to other participants is prevented. The footrest must be fitted at a height of at least 150 mm from the ground.

01.41 BRAKES

41.01

Brakes are not permitted on Track Racing motorcycles except for flat track.

01.43 MUDGUARDS AND WHEEL PROTECTION

Motorcycles must be fitted with mudguards.

43.01

Mudguards must project laterally beyond the tyre on each side. Both front and rear mudguards must be made of flexible materials (e.g. solid and rigid plastics, composite materials) and the mudguards shall not cause any injuries when damaged.

43.03

For Speedway and Long Track, a front mudguard which follows the contour of the wheel, must extend at least 5° in front of a vertical line running through the bottom of the front fork steering stem axis and at least 200 mm from the same point towards the rear. A rear mudguard must extend at least 5° behind a vertical line running through the centre of the rear wheel axle.

If the distance from the rear wheel tyre surface and the rear end of the rear mudguard is greater than 35mm, an additional wheel protection must be fitted. The gap between the wheel and the wheel protection must not be larger than 35mm.

If a push bar is used, it should be made in one piece, of strong material which should deform under impact and must not protrude any higher than 35mm above the rear mudguard.

43.04

For Speedway: rear wheels, either laced with spokes, or cast, or welded, must be covered with a solid disc on the right-hand side. A gap between the rim section and the disc shall not be larger than 10 mm. Sidecars must use a protective cover on front wheels which are cast or welded.

For Long Track, this protective disc is compulsory.

43.06

For Track racing Sidecars, the mudguard of the rear wheel and the mudguard of the Sidecar must extend down at the rear to a maximum of 200 mm from the ground (see Diagram L).

43.07 Mudguards for Ice Racing

Mudguards must project laterally beyond the tyre on each side and the top half of the wheel (in circumference) must be completely covered (see Diagram H for dimensions).

The front mudguard should be made from composite materials. The material shall be of appropriate strength and design and not to break or collapse under impact. Where necessary this may be achieved by the incorporation of reinforcement (for example a tubular protection of continuous construction) fixed to the front suspension.

The guard must be properly fixed to the front suspension.

The mudguard and/or the associated protection required must be designed to extend down at the rear of the wheel to a maximum of 250 mm from the surface of the ice and at the front must extend down to a maximum of 200 mm from the ice surface (see Diagram H).

On both sides of the front wheel the front mudguard must also extend down to the wheel spindle so that the top half of the wheel and the tyre are completely covered.

The rear mudguard should be made of composite materials and extend down at the rear of the wheel to a maximum of 250 mm from the ice surface.

On both sides of the rear wheel the rear mudguard must extend down to a maximum of 100 mm from the wheel spindle so that the top half of the wheel and the tyre are completely covered.

Additionally, a guard must be fitted to provide protection in front of the rear wheel in order to avoid the left leg getting injured by spikes.

43.10

Protection from the Sidecar wheel and the rear wheel for the passenger must be provided down to the level of the Sidecar platform.

43.11

The outside of the Sidecar wheel must either be completely covered by a disc extending to the wheel rim, or, the Sidecar mudguard must extend downwards on the outside to the centre of the wheel spindle.

01.45 STREAMLINING

Streamlining is permitted.

Streamlining should be made of flexible materials (e.g. solid and rigid plastics, composite materials) and must not break under impact. Streamlining must not have any sharp corners and must be properly fixed to the motorcycle.

01.46 INCLINATION AND SUSPENSION OF MOTORCYCLES

The minimum angle of inclination for Ice racing machines is 68°.

01.47 WHEELS, RIMS AND TYRES (See Table 01.86)

All tyres will be measured mounted on the rim at a pressure of 1 kg/sq.cm (14 lb./sq.in); measurements are taken at a tyre section plane with a 90° angle with the ground plane.

47.02

The Rear rim size is 19" and the maximum width is 2.50".

Any modification to the rim or spokes of an integral wheel (cast, moulded, riveted) as supplied by the manufacturer or of a traditional detachable rim (other than for spokes, valve or security bolts) is prohibited.

The only exception made is for tyre retention screws sometimes used to prevent tyre movement relative to the rim. If the rim is modified for these purposes, bolts, screws, etc., must be fitted.

47.03

Tyres must be inflated / filled by air only. No other substance shall be used to increase overall weight. Balancing weights only may be added and attached only to the rim or spokes.

47.04

The use of tractor pattern tread tyres is prohibited. The use of chains and any other non-skid device is prohibited (except for disciplines on Ice).

01.49 TYRES FOR 250cc/500cc SPEEDWAY AND SPEEDWAY SIDECARS (See Diagrams G bis)

49.01

The overall width of the rear tyre must not exceed 100 mm (O).

49.02

The tread depth (A) must not exceed 8 mm measured at right angles to the face of the tread. All blocks in the same circumference must be of the same depth.

49.03

The space between the blocks must not exceed 9.5 mm across the tyre (B) or 13 mm in a circumferential direction (C).

49.04

The space between shoulder blocks (D) must not exceed 22 mm.

49.05

The space across the tread (E) must not extend completely across the tyre measured at right angles to the wall of the tyre, unless broken by a block.

49.06

All tread block (with the exception of the shoulder) must be nominally rectangular with sides parallel with or at right angles to the tyre axis (tyre must have same appearance when reversed and conform in principle with Diagram G bis).

49.07

The tyre surface must not be fitted with any subsequently mounted elements such as anti-skid spikes, special chains, etc.

49.08

All tread blocks (shoulder and main) may be laminated by the manufacturer with a maximum of 3 X 0.5 mm wide slots (sipes) per block, in the original mould.

Subsequent tyre modification(s) of any type are not permitted under any circumstances. (Tyres may not be treated by chemicals, tyre warmers or any other means, which may alter the shape, minimum Shore hardness, construction or other characteristics).

49.09

For the front tyre, the only restriction is the overall width which is limited to 80 mm maximum.

49.10

Rear tyres must have a minimum Shore hardness of 70 (± 2) at 20°C.

49.11

The overall width (Art. 49.01) and the Shore hardness (Art. 40.10) of the rear tyres must be measured through a TUV laboratory or a similar Institute. The manufacturer shall send a sample of the rear tyre to the FIM and the FIM will take care of sending the sample to the laboratory. Depending on the results of the tests, the FIM shall issue a homologation number. The manufacturer will then engrave this number of the tyre mould: FIM/XX + Year of homologation.

The FIM reserves the right to take rear tyres from the race and perform post-homologation controls.

49.11

The rear tyre must be measured mounted on a rim, type WM 3 - 2.15 x 19" rim.

01.50 TYRES FOR 250cc/500cc LONG TRACK

50.01

The dimension of the rear tyre for long track must have a rim diameter of 22" and a maximum width of 100 mm.

The tread depth (A) must not exceed 11 mm measured at right angles to the face of the tread. All blocks in the same circumference must be of the same depth (see Diagram G bis).

50.02

There is no restriction on the size or type of the front tyre.

50.03

The tyre delivered by the manufacturer must not be subsequently altered or cut.

01.51 TYRES FOR ICE RACING

51.01

The tyre must be of special design.

51.02

The tyre's surface must have anti-skid spikes. These spikes must ensure safe and fully controllable driving on ice.

51.03

Spikes shall be made from tempered steel only.

The maximum length of the spike, measured from the flat top surface of the fastening plate (washer): 28 mm.

Maximum thickness of the fastening plate (washer): 6 mm.

Minimum diameter of the top of the fastening plate: 15 mm and must be flat.

Maximum diameter on the base of the fastening plate: no limit.

The tubular gauge must have a maximum internal diameter (ID) of: 15 mm (unchanged).

51.04

No spikes shall exceed through a line, the vertical tangent on the extreme right-hand side of the tyre.

51.05

The front tyre must have a maximum width of 100 mm and be fitted to a wheel rim of maximum diameter 23".

51.06

The rear tyre must have a maximum width of 100 mm and be fitted to a wheel rim of maximum diameter 21".

01.52 WHEELS, RIMS AND TYRES FOR TRACK RACING SIDECARS

52.01

Front wheel:

- Minimum rim diameter: 18"
- Minimum diameter wheel spindle: 15 mm tempered steel shaft permitted only
- Minimum diameter of spokes: 3,5 mm M4, steel construction
- Spoke lacing must cross twice

Rear wheel:

- Min. rim diameter: 18" (19" for 500cc Sidecars). Max. rim diameter: 22"
- Minimum diameter wheel spindle: 17 mm, tempered steel shaft permitted only
- Minimum diameter of spokes: 4 mm, M4, steel construction
- Spoke lacing must cross twice
- Maximum tyre width: 100 mm (for 500cc Sidecars only)

Sidecar wheel:

- Min. rim diameter: 16"
- Minimum diameter wheel spindle: 25 mm, tempered steel shaft permitted only
- Minimum diameter of spokes: 4 mm, M4, steel construction
- Spoke lacing must cross twice

52.03

Spindle sleeves must be secured by supplementary self-locking nuts, e.g. nyloc or castle nuts with split pins.

52.04

The minimum width between the wire spoke flanges at the hub must be 75 mm (see Diagram 1). The spoke holes must be countersunk on both sides. Plastic hubs are forbidden.

52.05 Sidecar wheel

52.05.1 Maximum wheel inclination of 30°, measured from the vertical to the inside (controlled by angle measuring instrument and spirit level).

52.05.2 Position: One-sided wheel spindle diameter of 25 mm at the point of the highest moment of deflection; tempered steel (see Diagram 2), or with a diameter of 15 mm if supported on both sides of the wheel.

The Sidecar wheel spindle must not be welded in position. It must be screwed on, for example, by a collar or clamp, with at least three M8 screws.

The minimum length of the clamp is 100 mm. A protective device must be provided to ensure against the loss or failure of the clamp. The construction of the clamp must be fixed to the main tube of the Sidecar frame.

The wheel bearing must be self-locking, e.g. nyloc or castle nut with split pins.

52.09

There is no restriction for the size or type of the front or Sidecar tyres. The tyre tread pattern must remain as designed by the manufacturer.

01.53 ADDITIONAL SPECIFICATIONS FOR 500cc SIDECARS

For a more detailed indication, please refer to Diagrams 1,2,3,4.

53.01 Sidecar construction

The Sidecar must be fixed to the motorcycle in at least three points, if it is not an integral part of the chassis.

Hinged/pivoted Sidecars are strictly forbidden.

The angle of inclination of the motorcycle chassis, with respect to the vertical line to the ground, must not exceed 15 degrees, and the Sidecar wheel must not exceed 30 degrees (refer to Diagram 4).

There must be no movement on any part of the Sidecar fixing points. If the angle of the inclination is changeable, it must be locked in such a way that it is completely secured and not just clamped in position.

The fuel tank and oil tank must be securely mounted and positioned behind the steering head.

53.03 Wheel spindles and headstock bolts

These fixtures must be of a solid construction and not drilled or lightened. They must be fitted with either a self-locking nut or split pin to ensure that the fixing does not become loose or come apart during racing.

53.04 Front forks

The front forks of the motorcycle must be securely fitted to the headstock using a headstock spindle of minimum 14mm diameter.

53.05 Steering

The steering of the front wheel must be via 'leading link' front forks, with the wheel supported equally each side (long or short leading link type). All other types of front wheel steering and suspension are forbidden.

53.06 Drive

The drive shall be transmitted to the ground only through the rear wheel of the motorcycle.

53.07 Rear wheel and Sidecar wheel offset

The distance between the tracks left by the centre lines of the rear motorcycle wheel and the Sidecar wheel must be at least 800 mm and must not exceed 1100 mm.

53.08 Wheel protection

For Sidecars, the rear wheel and the Sidecar wheel must be covered or protected with a solid material.

53.09 Wheel displacement

To reduce the torque in the steering, a maximum displacement of 75 mm is permitted between the front and the rear wheel.

53.10

The outside Sidecar wheel shall be provided with a protective horizontal steel tube (minimum tube diameter: 22 mm), fixed at the same height as the Sidecar spindle. No component shall protrude beyond this protective tube.

53.11 Sidecar dimensions

The minimum dimensions of a Sidecar available for passenger accommodation are:

Length: 1 000 mm - Width: 400 mm.

53.12

The minimum ground clearance at the front edge of the Sidecar platform is 150 mm. The ground clearance of a laden Sidecar (with a rider and passenger) must not be less than 100 mm at any point.

53.13 Engine position

The position of the engine is optional, except that it must be positioned in front of the rear wheel.

The centre line of the engine corresponds to the crankshaft axis (for longitudinal engines) and to the centre line of the cylinders block (for transverse engines). The centre line of the engine shall not exceed more than 160 mm beyond the centre line of the rear wheel of the motorcycle.

If the engine and gearbox are mounted on plates, the minimum thickness of the Al-based alloy engine plates must be 8 mm.

53.14 Carburettor

The maximum diameter of the carburettor induction tract will be of 38 mm (refer to Diagram 4).

53.15 Handlebars

Handlebars must be firmly secured to the forks. They must be at a height above the mid-point in the seat.

The motorcycle must have a steering head which must be fitted like the handlebar, and must not be attached to the unsuspended part of the front wheel suspension.

53.16 Rider's seat height

The minimum height of the rider's seat shall be 400 mm, measured from the ground in a fully loaded (e.g. with rider and passenger) position.

53.17 Exhaust system

The exhaust system must not extend beyond the outer circumference of the rear tyre, and must not end before the centre of the rear wheel spindle.

The motorcycle exhaust system must be securely fixed at four points – the point of fixture at the cylinder head is considered as one point.

The silencer must be fitted to the frame with at least one fixing (refer to Diagram 3).

Additionally a second flexible fixing must be fitted from the first third of the silencer to the frame. This second flexible fixing should be a steel cable of at least 3 mm diameter or a strong steel spring. The silencer must be of a type that is currently listed within the FIM Technical rules.

The silencer must be fitted with a suitable heat shield.

01.54 ADDITIONAL RULES FOR 1000CC SPEEDWAY SIDECARS

54.01 Definition

54.01.1 To be deemed as eligible for competition in sidecar events on track racing circuits, the machine shall be in conformity with the following requirements:

54.01.2 The motorcycle must have three rolling wheels. The sidecar wheel must be on the left of the machine. The drive shall be transmitted to the track surface through the rear wheel of the motorcycle.

54.01.3 The motorcycle must at all time carry a driver and a passenger.

54.01.4 Brakes are not permitted.

54.01.5 Rear wheel suspension is optional.

54.01.6 The passenger must sit astride the motorcycle.

54.01.7 The motorcycle shall always race in a clockwise direction.

54.02 Dimensions

54.02.1 The overall length from leading edge of the front tyre to outside of the rear mudguard must not exceed 2600 mm.

54.02.2 The overall width must not exceed 1500 mm.

54.02.3 The wheelbase, measured from the centre of the front spindle to the centre of the rear spindle, must measure between 1280 mm and 1800 mm.

54.02.4 The wheel track, measured between the centre lines of the track left by the rear and sidecar wheels, shall be a minimum of 800 mm and a maximum of 1100 mm.

54.02.5 The front and rear wheel must be aligned as such that the centre line of the tracks made by the motorcycle is proceeding directly forward, must be no further apart than 75 mm.

54.02.6 The width of the running board on the right of the motorcycle must not exceed 400 mm.

54.02.7 The angle of inclination of the main body of the motorcycle must not exceed 10° degrees from the vertical.

54.02.8 The minimum ground clearance at any point of the sidecar shall be 75 mm unloaded.

54.03 Engine

The engine capacity shall not exceed 1000cc. Engines may be bored up to 1045cc (no further tolerance).

54.04 Minimum weight: 180kg.

54.05 Fuel, Oil and Coolants

Methanol or unleaded fuel is the only permitted fuel. The use of octane boosters is forbidden.

On liquid engines, an overflow pipe must direct any overflow coolant away from the rider and passenger and into a catch tank.

For environmental reasons, the rider/team/mechanic must at all times place a receptive container or an environmental mat under the motorcycle to catch waste oil and coolants, etc., when working in the pit-area during an event.

54.05.1 The use of fuel additives is prohibited, with the exception of oil for two stroke engines.

54.05.2 Fuel injection is permitted.

54.05.3 Fuel tanks must be constructed of a material that neither shatter or splinter upon impact, and must be mounted to the rear of steering headstock.

54.06 Exhaust systems

54.06.1 Exhaust pipes and silencers may be of a “baffle” or “absorption” type and must fulfil the requirements concerning noise control.

An exhaust extraction (megaphone types) effect must not be caused by the positioning of any tapered, conical or other shaped parts.

54.06.2 The exhaust pipe must be fixed to the cylinder head and frame with a minimum of three (3) clips (the point of fixture at the cylinder head is considered as one clip). The silencer must be fixed to the frame with at least one clip.

Additionally, a second flexible coupling must be fitted from the first third of the silencer to the frame (steel cable of at least 3 mm \varnothing for reasons of safety) or a solid steel spring.

54.06.3 Exhaust fumes must be discharged towards the rear but not in a manner as to raise dust, foul the tyres, or inconvenience a passenger, if there is one, or any other riders.

54.06.3 The entire exhaust system must be contained within the fairing, to ensure that the exhaust system cannot come in contact with any rider, passenger, or motorcycle.

54.07 Wheels, Rims and Tyres

54.07.1 The only permitted rear tyre are the FIM Homologated Speedway tyres.

The rear tyre must be marked (by the Technical Steward).

Front tyre and sidecar tyre must be of a Trial or Enduro type pattern.

Maximum sizes for rear wheel rim: 5.00"x19"

54.07.2 The sidecar wheel diameter must be between 16 and 19 inches, and must camber inwards.

54.07.3 The inside of spoked, cast or welded wheels must be covered with a disc or a shield.

54.07.4 The sidecar wheel can be mounted with plates on both sides, in which case the spindle diameter is min.12 mm. If the sidecar wheel is mounted with a bracket on one side, the spindle diameter is min.20 mm.

54.07.5 The rear and front wheel must be fitted with knockout spindles. The use of light alloys and titanium in the manufacturing of wheel spindles is forbidden.

54.08 Sidecar Platform

54.08.1 If the sidecar platform is not an integral part of the frame, the platform must be rigidly fixed to the motorcycle in at least four places.

54.08.2 Any space between the sidecar platform and the rear wheel of the motorcycle must be covered to ensure that the passenger's hands and feet cannot be trapped in the driving chain or the rear wheel.

54.08.3 The sidecar wheel must be contained within a continuous 25 mm horizontal crash bar, fixed rigidly to the sidecar platform at sidecar floor height.

Any open area in the sidecar platform inside the continuous crash bar, and on the running board on the near-side, must be filled with a suitable material to prevent either the rider or passenger from trapping their feet.

54.09 Dirt Deflectors, Mudguards, Fairings

54.09.1 A dirt deflector is compulsory and must be **declared eligible for competition** by the FIM. See Art. 58.03.1 for dirt deflector details.

54.09.2 The Dirt Deflector arm must be positioned to ensure that the blade and flap are correctly positioned behind the rear tyre.

54.09.3 The rear mudguard must be fitted and extend from the rear seat to a maximum of 150 mm from the ground with the sidecar occupied or with ballast.

54.09.4 The outside of the sidecar wheel and tyre must be covered by a non-rotating shield or fairing. This fairing must be securely fixed to the sidecar and outside of the crash bar.

54.09.5 All fairings and nose cones must be constructed of fibreglass, plastic, or similar material. They must be smooth, free of any sharp or protruding edges, and must not provide a danger to any other competitor. The minimum clearance between streamlining and the ends of the handlebars or their attachments is 30 mm with the front wheel in any position. No aero foils or similar devices are permitted.

54.09.6 No part of any nose cone or fairing may extend beyond a vertical line drawn through the leading edge of the front tyre. No part of the sidecar fairing may extend beyond a vertical line drawn at a tangent to the rear edge of the back tyre.

54.10 Frame

The use of titanium and composite materials in the construction of a frame and swing-arm is completely forbidden

54.11 An efficient steering damper must be installed.

01.55 NUMBER PLATES

55.01 Speedway World Championships / Cups / Trophies

For the Speedway machines, the number must be displayed on **the right** side of the motorcycle.

Each number must be marked in such a manner as to be clearly visible and must not be masked by any part of the motorcycle or by the rider when seated in the driving position.

The numbers must fit in the space between the upper part of the rear sub-frame, the bottom edge of the rear mudguard and the lifting handle.

The figures must be clearly legible and like the background must be painted in matt colours to avoid reflection from light. The minimum dimensions of the figures being:

Height of figure: **100** mm

No other number markings on a motorcycle liable to cause confusion will be allowed and must be removed before the start of a competition.

55.02 For Ice Racing

For Ice Racing World Championship Events:
The number must be displayed on the front of the motorcycle.

For Ice Racing Final Series:
The number must be displayed on the front and on the front mudguard of the motorcycle.

Background color: RAL 5019
Numbers minimum height: 120mm
Numbers color: White
FIM and ISG logos are COMPULSORY



55.03 Long Track World Championship

The number must be displayed on the front and on **right** side of the motorcycle.

Each number must be marked in such a manner as to be clearly visible and must not be masked by any part of the motorcycle or by the rider when seated in the driving position.

The figures must be clearly legible and like the background must be painted in matt colours to avoid reflection from light.

The minimum height of the number figures must be 120 mm.

Background color: RAL 1023
Numbers minimum height: 120mm
Numbers color: black
Long Track logo is COMPULSORY



55.04 250cc Long Track and 125cc Track Racing

The number must be displayed on the front and on the **right** side of the motorcycle.

Each number must be marked in such a manner as to be clearly visible and must not be masked by any part of the motorcycle or by the rider when seated in the driving position.

The figures must be clearly legible and like the background must be painted in matt colours to avoid reflection from light.

The minimum height of the number figures must be 120 mm.

55.05 Sidecars

The number must be displayed on the front and at least one side of the vehicle (right side for 500cc and left side for 1000cc).

Each number must be marked in such a manner as to be clearly visible and must not be masked by any part of the motorcycle or by the rider when seated in the driving position.

The figures must be clearly legible and like the background must be painted in matt colours to avoid reflection from light.

The minimum height of the number figures must be 150 mm.

The English form for numbers must be used. That is single vertical line for the "one" and a simple sloping line without a horizontal line for the "seven".

All other number markings on a motorcycle liable to cause confusion with the number must be removed before the start of a competition.

55.12 Number Plate Colours

The colours must be matt, following the RAL colour table, i.e.:

Black	9005
Blue	5010
Yellow	1003
Red	3020
Green	6002
White	9010

55.12.1 For Long Track: yellow background, black numbers.

55.12.2 For 1000 cc Sidecars: black background, white numbers.

55.12.3 For 125cc Track Racing motorcycles: green background, white numbers.

55.12.4 For 250cc Long Track: blue background, white numbers.

55.13

In case of a dispute concerning the legibility of numbers, the decision of the Technical Steward will be final.

01.56 OIL CATCH TANKS

All motorcycles with a closed oil system must be equipped with an oil catch tank with a minimum volume of 300 cc to be fitted over the breather pipe on the engine.

All motorcycles with a total loss oil system must be equipped with an oil catch tank with a minimum volume of 300 cc to be emptied after each heat or race.

When the engine is running the bottom of oil catch tank must be closed.

01.57 ENVIRONMENTAL MAT

When bikes are placed in the pits, parc fermé or other parking area the use of an Environmental Mat is compulsory for all Riders and all their bikes. It must be used whenever working or parking the bikes, during practice and racing.

01.58 SPECIFICATION FOR TRACK RACING MOTORCYCLES

58.01 General

Machines must be fitted with a single cylinder 4-stroke engine with a maximum capacity of 250cc or 500 cc, 4 valves maximum, fitted with one (1) carburettor with a diameter of 34 mm and one spark plug. For 500 cc Sidecars, a diameter of 38 mm is compulsory.

58.02 Carburation instruments

A section of the carburation instrument induction tract must have a constant, circular section with a diameter of 34 mm (+ 0.1 mm). For 500cc Sidecars the diameter is 38 mm (+ 0.1 mm). Only one (1) single fuel nozzle is permitted. No other additions are permitted in the air induction tract.

On the air intake side, this circular section will be measured from the slide/throttle valve edge over a minimum length of 5 mm.

On the engine side, this circular section will be measured from the slide/throttle valve edge, over a minimum length of 25 mm.

On the engine side, an additional hole (maximum diameter 6 mm) is permitted to be used for engine starting purposes (choke). (See Diagrams G, H, K, L)

For two-valve engines:

An additional jet and/or an additional hole (maximum diam. 2 mm) on the engine side is authorized to improve the engine's response at lower rpm.

58.03 Dirt Deflector

Dirt deflectors are compulsory in 250cc/500cc Speedway, Long Track and Sidecars.

All dirt deflectors must be **declared eligible for competition** by the FIM.

MANUFACTURER	PRODUCT IDENTIFICATION	VALID FROM
BRIGGO	BBDD/96/A/All	01.01.1998
BRIGGO	FIDDBBR/9712/SCB01	01.01.1998
DAVE STANDING	DASDD/97/A/All	01.01.1998
JAWA	DD-JAWA/2000/03	01.01.2000
JAWA	FIM	01.01.2002
EZ	FIM	01.01.2002

58.03.1 Dirt Deflector-Specifications

The dirt deflectors used must be within these specifications and must be fitted to the machine and presented at the technical control.

58.03.2 The dirt deflector arm(s) and pivot mechanism must be constructed of the highest grade materials, permitting minimal distortion and maximum durability under all riding conditions.

58.03.3 The dirt deflector flap holder must be constructed of a non-metallic material (except for Longtrack and Sidecars).

The dirt deflector 'flap' must be easily replaceable and constructed of a resilient, non-metallic material. The dirt deflector flap must remain effective under all track surface and wind conditions.

The dirt deflector flap must be shaped and positioned in such a way that the distance of the upper flap edge to the complete tyre tread width is 18 mm (+/-5 mm). The opposite lower edge shall be 35 mm maximum from the track surface over an equal distance.

Outside of this centre section, the deflector flap lower edge may slope up to a maximum of 50 mm above the track surface.

58.03.4 The deflector flap must be set at an angle, between 30° degrees and 50° degrees maximum to the track surface, measured on the longitudinal centre line of the machine.

A manufacturer must show the designed angle on any published instruction. The permitted fitting tolerance on the designed angle is +/- 5° (degrees) (see also Art. 58.03.9 and Diagram S).

58.03.5 The deflector flap must not be less than 250 mm and not more than 300 mm in overall width. The flap centre must be positioned within a 10 mm off-set to the left of the tyre centre line, in the normal riding position.

The flap holder must not be less than 100 mm and not more than 160 mm in overall width.

58.03.6 No part of the dirt deflector shall be more than 75 mm behind the vertical tangent to the rearmost point of the tyre when fitted in the normal operating position.

58.03.7 The dirt deflector arm(s) must be able to pivot a minimum of 25° (degrees) in an upward direction to allow safe operation when the front wheel lifts.

58.03.8 Any pivot arrangement must have its centre of rotation a maximum of 70 mm from the rear wheel axis.

58.03.9 A mechanism must maintain constant function of the pivot arrangement and be able to return the dirt deflector 'flap' to its normal operating position with minimal delay.

To measure the tension provided by the mechanism of the dirt deflector, a vertical balance shall be used to measure an equivalent minimum pre-load of 2.5 kg for dirt deflectors used in Speedway and an equivalent minimum pre-load of 8 kg for dirt deflectors used for Long Track, Track Racing and 1000c Sidecars.

The vertical balance must be attached to the outer edge of the dirt deflector flap in line with the centre of the rear tyre.

58.03.10 All measurements are taken with the machine in a vertical position, with the tyres normally inflated without a rider.

58.03.11 The complete dirt deflector must be **declared eligible for competition** by the FIM. The manufacturer must supply drawings and photographs of the dirt deflector at the time of homologation. The manufacturer must engrave on each dirt deflector: FIM DD/Year/Homologation number (issued by the FIM).

The FIM reserves the right to sample dirt deflectors at any time to compare with the original homologated dirt deflector.

The inter-face of the dirt deflector may be altered to allow a correct assembly to a particular frame construction; however, the dirt deflector must retain its normal function.

Subsequent to FIM homologation, the dirt deflector's design (i.e. flap, flap-holder, arm(s) or pivot point) must not be altered in any way. The only changes allowed are engineering and/or production enhancements, by written document to the FIM.

58.04 Carburettor

The carburettor must be fitted with an efficient cartridge type air filter.

01.59 SPECIFICATION FOR ICE RACING MOTORCYCLES

Only 2-valve engines are allowed.

01.65 EQUIPMENT AND PROTECTIVE CLOTHING DURING PRACTICE AND RACE

The FIM cannot be held liable for any injuries that a rider or passenger may sustain from the use of a specific item of equipment or protective clothing.

65.01 Clothing and protectors

As a minimum, it is compulsory that riders/passengers wear a suit.

The suit:

- shall consist of a one-piece overall (as used in 'circuit racing'), or an upper and lower segment joined by a zip or similar (for Flat Track, trousers and long-sleeve shirt are also permitted);
- may have elastic-stretching material inserts under arms, behind the knees and in the groin to allow for freedom of movement when worn;
- shall have a thickness of 1 mm minimum (for Flat Track, it is not required);
- shall be non-toxic and non-allergenic;
- shall not be made of nylon or spandex (e.g. Lycra, Elastan) material (for Flat Track, it is only recommended not to use nylon or spandex);
- **The race suits must comply with EN 17092 level AAA or AA. Until December 31st 2023, the use of leather complying with EN 13959 is accepted.**

Especially where the suit is not fully made of leather, it is highly recommended that riders/passengers also wear a liner.

The liner:

- shall comprise ribbed panels of moulded plastic, with a minimum thickness of 2 mm, covering shoulders, elbows, chest, back, hip joints and knees;
- it is recommended that the liner comply with EN 13595-1,2,3,4; this means having significant impact abrasion resistance, seam burst strength, impact cut resistance, a high melting point and low heat conductivity.

Moreover, it is compulsory that riders/passengers wear a back protector, incorporated within the suit or the liner or worn separately. The back protector shall comply with EN 1621-2.

It is recommended that, in addition, a chest protector and other padding which protects shoulders, elbows, hip joints and knees (all compulsory for Ice Speedway and for Flat Track in case the clothing is thinner than 1 mm), be worn.

For chest and hip joints, the padding should comply with EN 1621-3 (or EN 14021) and EN 1621-1, respectively.

Repaired overalls are acceptable provided that the repair guarantees protection to the same standard as the original garment. The Chief Technical Steward has to right to refuse any temporary repairs which are not deemed to provide the same protection as the original garment.

65.02 Footwear

Footwear, in a good condition, made of leather or other materials having equivalent properties, shall be worn and have a minimum height of 30 cm.
For Ice Speedway, at least 3 studs must be fitted to the sole of the rider's right boot.

65.03 Gloves

Riders/passengers shall wear gloves made of leather or other materials having equivalent properties.

65.04 Googles

Riders/passengers must wear face shield/goggles.

01.67 WEARING OF HELMETS

- It is compulsory for all participants taking part in practice and races to wear a protective helmet. The helmet must be properly fastened, be of a good fit, and be in good condition. The helmet must have a chin strap type 'retention system'.
- A protective lower face cover must be present and must be not detachable, not moveable.
- Helmets constructed with an outer shell made of more than one piece are not permitted (e.g. they must not contain any seam).
- A retention system with a strap and the double D ring closing system is recommended.
- All helmets must be marked with one of the official international standard marks mentioned in Art. 01.70. Any FMN approval marks do not substitute the official international standard marks.
- A helmet is made to provide protection. It is not a platform to attach foreign objects. Cameras and/or other accessories are NOT permitted nor shall be attached to the rider's helmet.

Failure to observe the above rules will entail exclusion.

01.68 HELMET COLOUR

Every Rider (for Speedway Sidecar, both the Rider and the passenger) shall have at least one (1) coloured helmet or one (1) helmet cover in each of the prescribed colours ready for use in accordance with the rules in force for the meeting.

Any alterations, additions or changes to the helmet (to the shape of the helmet, colouring, etc...) that may affect the structure or durability of the helmet may be made only in accordance with the manufacturer's precise recommendations and specifications.

In every heat, and according to the allocated gate position, the Riders (for Speedway Sidecar, both the Rider and the passenger) must use the coloured helmet or the helmet cover, in the corresponding colour, for proper identification to the Referee, TV, spectators, etc.

The prescribed helmet colours used are (RAL traffic colours):

RED	3020
BLUE	5017
WHITE	9016
YELLOW	1023
GREEN	6024
BLACK/WHITE	9005/9016

The Rider's and passenger's helmets or covers used must be coloured or produced in these prescribed colours.

The coloured area on helmets shall correspond to the area indicated with parallel lines in Diagram A (if paint is used only) or Diagram B (if a textile helmet cover is used only).

On the coloured area it is permitted to have one advert with maximum area of 50 cm².

Every Rider's and passenger's helmet or helmet cover is considered as a part of his personal equipment and must be presented to the technical scrutineering.

01.69 HELMET OPERATIVE INSTRUCTIONS

69.01

Scrutineers, under the supervision of the Chief Technical Steward, may check prior to practice and the races that all helmets meet the technical requirements.

69.02

If a helmet does not meet the technical requirements or is found to be defective, the Technical Steward clearly mark in red (e.g. with a red dot) all international marks without destroying them and retain the helmet until the end of the event. The rider must submit another helmet for approval by the Technical Steward. After an accident involving impact, the helmet must be presented to the Technical Steward for examination (see also Art. 77.02.14).

69.03

All helmets must be intact and no alteration must have been made to their construction. After an accident involving impact the helmet must be presented to the Technical Steward for examination.

69.04

The Chief Technical Steward and/or the Technical Steward may perform the following checks before the rider is permitted to take part in practice of the race:

69.04.1 That the helmet fits well on the rider's head.

69.04.2 That it is not possible to slip the retention system over the chin, when fully fastened.



69.04.3 That it is not possible to pull the helmet over the rider's head by pulling it from the back of the helmet.

01.70 RECOGNISED INTERNATIONAL HELMET APPROVAL MARKS

Helmets must conform to one of the recognised international standards:

EUROPE	ECE 22-05 or ECE 22-06 (only "P" type)
JAPAN	JIS T 8133:2015 (only "Type 2 Full face")
USA	SNELL M2015 or SNELL M2020D or SNELL M2020R

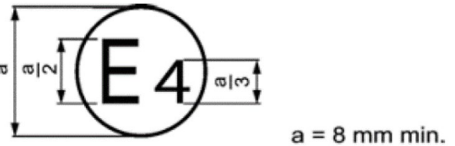
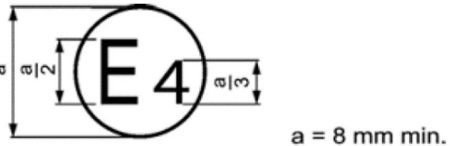
Examples of labels are reported below (for Europe, the country numbers which have granted the approval are also indicated):

<p>EUROPE</p>	 <p>051406/P-1952</p>	 <p>061406/P-1952</p>
<p>JAPAN</p>		
<p>USA</p>		

01.75 BADGE OF THE FIM

Under certain circumstances the FIM may permit the use of the FIM badge on certain equipment in order to show that the latter conforms to the standards laid down by the FIM. When this authorisation is granted and provided the equipment on which it appears is in good condition, the badge is then the guarantee of the conformity with the standard set by the FIM.

01.76 SCRUTINEERING

Before practice, a safety check of all engines and machines is required.

Before racing, all engines and machines must be checked for compliance with current regulations.

Engines and machines, which do not comply, are prohibited.

Furthermore, if a machine is not in compliance with the current regulations after any heat, the Rider may be disqualified from that heat.

In all FIM Championship meetings, the cylinder capacity and carburettor-choke size of all engines of all machines, employed by any Rider may be verified immediately after the last heat.

The weight of some machines, chosen at random, may also be checked during and/or immediately after racing.

The Referee may order any engine or machine to be rechecked or re-tested at any time during practice or racing.

At all FIM Championships, Official FIM specification declaration forms are provided by the FIM for machine verification and signed by the Technical Steward.

The Rider or his representative or the mechanics must be present, with the machines, at the time stipulated in the SRs.

As soon as a Rider is known to have completed all heats (including substitutions, semi-final/final where applicable) all motorcycles used in the meeting must be taken immediately to the parc fermé where they must remain until released on instruction from the Jury to the Technical Steward.

01.77 TECHNICAL VERIFICATIONS

77.01 Preparation

- Prior to the Technical Verifications, it should be decided who is doing what and note decisions. "Efficiency" must be the watchword. Always keep cheerful and remember the reasons for scrutineering: SAFETY AND FAIRNESS.
- Before the START of the competition, a closed and guarded area (closed parc/parc-fermé) shall be prepared.
- Inspection must take place under cover with a large enough area.
- Inspection area must be supplied with the necessary equipment, including tables, chairs, electric light and power outlet.
- Weighing apparatus must be accurate, practical and have a minimum resolution of 500g (although 100g is recommended). Weighing scales must have been certified by a National Institute within the period of 24 months before the event. Certified master weights and their certificate must be available for verifying.
- The necessary tools are listed below:
 - ✓ Revolution meter
 - ✓ Sound meter, calibrator and spare batteries
 - ✓ Durometer for tyre control ('Shore' hardness gauge)
 - ✓ Slide calliper (for verifying engine capacity, carburettor diameter, etc.)
 - ✓ Depth gauge
 - ✓ Steel measuring tape
 - ✓ Arrangement for measuring ground clearance (for Sidecars)
 - ✓ Seals
 - ✓ Weighing apparatus (to be furnished by the Organiser) (and set of reference weights)
 - ✓ Tools for measuring the engine capacity
 - ✓ Lampoil tester is recommended and when used, it indicates the cylinder capacity. When a more precise measurement is required, the Chief Technical Steward may ask to take the cylinder head off the cylinder.
 - ✓ Colour for marking parts
 - ✓ Heat resistant stickers or paint for marking the silencer (and solvent)
 - ✓ Magnet
 - ✓ Adequate fuel sample bottles
 - ✓ PC with CD Drive + updated operating system
 - ✓ Printer, etc. are recommended
 - ✓ Calculator
- The necessary documents are listed below:
 - ✓ Supplementary Regulations
 - ✓ FIM Technical Rules - current year
 - ✓ FIM Rules of the discipline concerned
 - ✓ FIM Sporting Code
 - ✓ Homologation papers (if applicable)
 - ✓ Writing material
 - ✓ Technical Verifications forms

- All necessary measures and administrative equipment should be in place at least 1/2 hour before the start of the Technical Verifications is due to open (time in Supplementary Regulations).

77.02 Verifications

- The Technical Verifications before the official practice should last at least 30 min, before the race at least one hour, after the race last at least 30 min.
- The technical control must be carried out in conformity with the procedure and times fixed in the CCP Rules and the Supplementary Regulations of the event.
- The Sound control must be carried out first. The Sound level will be recorded in the technical card. The exhaust silencer will be marked with paint or sticker.
- An example of minimum verifications that shall be performed is given below:

INITIAL TECHNICAL VERIFICATIONS	TRIAL	MOTO CROSS	TRACK RACING	ENDURO	CROSS-COUNTRY RALLIES and BAJAS
Make + model	✓	✓	✓	✓	✓
Sound	✓	✓	✓	✓	✓
Cut-off switch	✓	✓	✓	✓	✓
Self-closing throttle	✓	✓	✓	✓	✓
Lights (front, rear, brake)	✓*			✓*	✓
Race fuel certificate	✓	✓	✓	✓	✓
Vehicle identification plate/chassis number				✓	✓
Crankcase				☐	☐
Wheels (hubs)				☐	☐
Registration plate + insurance (green card)				✓	✓
Weight + ballast	✓	✓	✓		
Fuel tank	✓				✓
Silencer	✓	✓	✓	✓	✓
Carburettor			✓		

Guard for the countershaft sprocket and rear sprocket	✓	✓	✓	✓	✓
Handlebar ends + protection + levers	✓	✓	✓	✓	✓
Front/rear brake disc protection	✓				
Side stand				✓**	✓
Tyres	✓	✓	✓	✓	✓
Helmet(s) + national colors	✓	✓	✓	✓	✓
Protective clothing	✓	✓	✓	✓	✓

* not applicable for closed circuits when specified in the Supplementary Regulations

** not applicable in SuperEnduro

- An overall inspection of the motorcycle must be carried out in conformity with the FIM rules. Accepted motorcycles will be marked with paint or a sticker.
- The Technical Verifications will be recorded on the Technical Verification form (see enclosed).
- The motorcycle must be weighed and the weight recorded in the technical card.
- During the event, the technical steward must control all machines and equipment. This control must be made before the machines enter onto the track.
- As soon as a rider has finished all his heats, all used machines must be immediately placed in a closed park where they must remain for 30 minutes, in case of a protest or should further examination be required.
- Competitors must retrieve their machines within 30 minutes after the opening of the closed park area, except for the machines which are chosen for disassembly. After this time limit, the closed park officials will no longer be responsible for the machines left behind.
- If required, a sound level control may be carried out before the machines are placed in the closed park.
- For the Technical Verifications taking place after the race, it shall be ensured that the selected machines used during the race go directly to the Closed Parc (Parc Fermé).

77.03 FMNR Chief Technical Steward and technical stewards

- The Chief Technical Steward must be in attendance at an event one hour before the Technical Verifications are due to begin. He must inform the Clerk of the Course/FIM Race Director and FIM Technical Director, if present, of his arrival.
- The Chief Technical Steward must ensure that all technical stewards appointed for the event carry out their duties in a proper manner. The Chief Technical Steward shall appoint the technical stewards to individual posts for the race, practices and final control.
- Scrutineers can have different tasks, but the team of scrutineers must have a minimum of three persons. The FMNR Chief Technical Steward must be a holder of an FIM SENIOR Technical Stewards Licence and it is recommended that at least one Technical Steward hold a FIM Technical Stewards Licence. A minimum number of scrutineers is required according to the following:
 - Checking of documentation: one
 - Sound test, silencer marking: two
 - Machine weight: one
 - Machine inspection, helmet and clothing: two
- The Sound Control Officer (SCO) must be holder of a valid FIM Technical Steward's license, come with good knowledge and experience of the sound control and application of the test method. The FMNR may propose the services from a special technician (acoustic engineer) if there is no FIM licenced Technical Steward available to act as SCO.
- The Technical Steward must fill in the technical card which must be signed by the rider.
- After the technical control has been completed the Chief Technical Steward will submit to the Clerk of the Course/FIM Race Director a list stating the names of the accepted riders and machines, the sound levels and weights of machines.
- If a motorcycle is involved in an accident, the Technical Steward must check the machine to ensure that no defect of a serious nature has occurred.
- If the helmet is clearly defective, the Technical Steward must retain it. The organiser must send this helmet, together with the accident and medical report (and pictures and video, if available) to the Federation of the rider. If there are head injuries stated in the medical report, the helmet then must be sent to a neutral institute for examination.
- The Chief Technical Steward has the right to look/ inspect any part of the motorcycle at any time of the event.
- All technical stewards shall be well informed and shall make sure their FMN has supplied them with all technical "updates" that may have been issued subsequent to the printing of the Technical Rules books.

77.04 FIM Technical Director

- The FIM Technical Director is appointed by the Director of the FIM International Technical Commission in consultation with the Director of the FIM Track Racing Commission.
- The FIM Technical Director is not responsible for the technical verifications but will ensure that they are carried out in accordance with the FIM Technical Code.
- The FIM Technical Director works in cooperation with the FIM Race Director/Jury President and the FIM Delegate/Clerk of the Course.
- The authority and duties of the FIM Technical Director include but are not limited to (Please, also refer to the FIM Technical Code):
 - a) The FIM Technical Director will report any concerns or deficiencies relating to the technical verifications to the FIM Race Director/Jury President and FIM Delegate and present proposals to resolve such concerns.
 - b) The FIM Technical Director is the final arbiter in relation to technical issues at the event.
 - c) The FIM Technical Director will examine with the Chief Technical Steward the motorcycle(s) and the protective equipment of any rider(s) involved in serious or fatal accidents and present a written report to the FIM Delegate/Jury President.
 - d) The FIM Technical Director will attend all meetings of the Race Direction/Jury meetings, but without voting rights.

77.05 Rider and/or mechanic

- The rider and/or the mechanic and/or Team Manager must attend at least once the Technical Verifications with the (rider's) machine within the time limits stated in the Supplementary Regulations.
- On request of the technical steward, the rider must present themselves to the Technical Verifications.

The maximum number of persons present at the technical verification will be the rider and/or the mechanic and/or Team Manager.

- A rider remains at all times responsible that his machine and his personal protective gear are in conformity with the FIM Technical Rules for Track Racing motorcycles.
- The rider and/or the mechanic and/or the Team Manager must present a clean motorcycle in conformity to the FIM rules.

- The rider is permitted to use whichever motorcycle he chooses from the accepted motorcycles. He may also use the motorcycle of another rider.
- The rider and/or the mechanic and/or the Team Manager must present the rider's protective wear (equipment), e.g. helmet and bib with prescribed starting number.
- Any rider failing to report as required by the provisions below may be excluded from the meeting.
- The Clerk of the Course/FIM Race Director may prohibit any person who does not comply with the rules, or any rider who could be a danger to other participants or to spectators, from taking part in the competitions.

01.78 DANGEROUS MACHINES

If, during practice or the race, a Technical Steward finds that a machine is defective and might constitute a danger to other riders, he must immediately notify the Clerk of the Course/FIM Race Director or his deputy. It is their duty to exclude such a machine either from the practice or from the race itself.

01.83 ADDITIONAL RULES FOR 85 CC SPEEDWAY MOTORCYCLES

In general, machines must comply with the technical requirements for Track Racing. In case of conflict, the present 'ADDITIONAL RULES FOR 85 CC SPEEDWAY MACHINES' have priority.

Providing a motorcycle confirms to the requirements of the FIM Track Racing regulations, as well as to a number of specific conditions that the FIM may require, no restriction is placed on the make, construction or type of motorcycle used.

83.01 Classes

Motorcycles may be equipped only with a standard, mass produced, 2-stroke, single cylinder engine, available to the public through the normal commercial sales channels of the original engine manufacturer.

The cylinder capacity may be over 50 cc and up to 85 cc, as originally produced by the manufacturer.

83.01.1 Minimum weights: 55 kg

83.01 Fuel, Oils and Coolants

All motorcycles for 85 cc Speedway must function on unleaded petrol with a maximum lead content of 0.005 g/l and a maximum MON of 90 (see also **FIM Fuels Regulation Track Racing** (Art. 01.63) for full specifications **available on www.fim-moto.com**).

Water-cooled engines must use a closed-circuit cooling system. Coolant may be carried in the frame.

The use of octane boosters is forbidden.

For environmental reasons, the rider/team/mechanic must at all times place a receptive container under the motorcycle to catch waste oil and coolants, etc., when working in the pit-area during an event.

83.03 Machine specifications

83.03.1 Engine

Any 'defect' or 'broken' parts may only be replaced by an 'original spare part', available and sold through the network of dealerships of the manufacturer in question.

83.03.2 Carburation Instruments

The originally fitted carburettor must be used. The only modifications permitted are jetting changes.

83.03.3 Exhaust pipe, silencer

The exhaust pipe and silencer must be fixed in a proper way and fastened on the motorcycle in a minimum of 3 different places.

Max. sound level: 115 dB/A (measured with the 2 metre max system).

83.04 Frame

83.04.1 Specifications

The maximum wheelbase is 1325 mm.

The use of titanium and composite materials is completely forbidden in the construction of the frame and swing-arm.

83.04.2 Brakes

Brakes are not permitted.

83.04.3 Wheel, Rim & Tyre Sizes

Front wheel rim size:	max. 3.00 (the diameter is free)
Front wheel tyre, max. width:	no restriction
Front tyre tread:	free

Rear wheel rim size:	max. 1.85" x 17"
Rear wheel tyre size:	max. 3.00" x 17"
Rear tyre tread:	must be of the type with 'trial' or 'track' tread.

83.04.4 Handlebars

Handlebars width: minimum 650 mm, maximum 850 mm.

83.04.5 Footrests

Refer to Art. 01.39.

01.84 TECHNICAL SPECIFICATIONS FOR 125 CC TRACK RACING MOTORCYCLES

In general, machines must comply with the technical requirements for Track Racing. In case of conflict, the present 'ADDITIONAL RULES FOR 125CC GRASS TRACK MACHINES' have priority.

Providing a motorcycle confirms to the requirements of the FIM Track Racing regulations, as well as to a number of specific conditions that the FIM may require, no restriction is placed on the make, construction or type of motorcycle used.

84.01 Classes

Motorcycles must be equipped with a single cylinder, 4-stroke engine, with a capacity between 100cc and 125cc (with the maximum limit of 129cc, to allow repairs)

84.01.1 Minimum weights: 60 kg

84.02 Fuel, Oil and Coolants

All engines must function on pure methanol or unleaded petrol with a maximum lead content of 5.0 mg/l and a maximum MON of 90 (see also **FIM Fuels Regulation Track Racing** (Art. 01.63) for full specifications **available on www.fim-moto.com**).

The use of octane boosters is forbidden.

Water-cooled engines must use a closed-circuit cooling system. Coolant may be carried in the frame.

For environmental reasons, the rider/team/mechanic must at all times place a receptive container under the motorcycle to catch waste oil and coolants, etc. when working in the pit- area during an event.

84.03 Machine specifications

84.03.1 Engine

Any 'defect' or 'broken' parts may only be replaced by an 'original spare part', available and sold through the manufacturers' dealership network.

84.03.2 Carburation Instruments

Maximum diameter: 29 mm. This measurement must be taken on the engine side from the slide/throttle valve edge.

Fuel injection systems are forbidden.

84.03.3 Exhaust pipe, silencer

The exhaust pipe and silencer must be fixed in a proper way and fastened on the motorcycle in a minimum of 3 different places.

Max. sound level: 115 dB/A (measured with the 2 metre max system).

84.04 Frame

84.04.1 Specifications

The use of titanium and composite materials is completely forbidden in the construction of a frame.

Purpose built speedway and long track frames may be used (long track frames must have a working rear suspension).

84.04.02 Brakes

Brakes are not permitted.

84.05 Wheels, Rims, Tyres

Front min 1" more than the size of the rear mounted wheel.

Rear min 17" – max 22"

Maximum tyre width of the rear wheel: 100 mm

Only tyres which conform to the Track Racing profile (trials universal type pattern/ track tread) can be used.

84.06 Handlebars

Handlebars width: minimum 650 mm, maximum 850 mm.

84.07 Footrest

Refer to Art. 01.39.

01.86

FIM HOMOLOGATED REAR TYRES

Tyres suitable for 125, 250 and 500cc Speedway, 1000cc Speedway Sidecar

BRAND	PRODUCT NAME	DIMENSION	FIM CODE	VALID FROM	IMAGE
	366 (out of production)	3.75-19	CT.SW.97.17	04.04.1997	
	SW-16A (out of production)	3.75-19	CT.SW.97.18	04.04.1997	
	SW-07 TT	3.75-19 61P	CT.SW.00.19	05.04.2000	
	SW-09 (out of production)	3.75-19	CTI.SW.06.320	01.01.2007	
	GT101	3.75-19/61P TT	FIM/GT 20912	01.01.2010	
		3.75-19 61P LRA	FIM/AT-374212	01.01.2013	
	SPEEDWAY REAR SB- 136 TUBE TYPE	3.75-19 61P	FIM/Deli 210J16	02.02.2016	
	"Speedway Rear SW- 01"	3.75-19 61P	FIM/JTR SW 30217	06.02.2017	
	"Speedway SW 002"	3.75-19 61P	FIM/ANSW 02020	09.10.2020	
	"Speedway SW 003"	3.75-19 61P	FIM/ANSW 03020	09.10.2020	

Diagrams

G Speedway

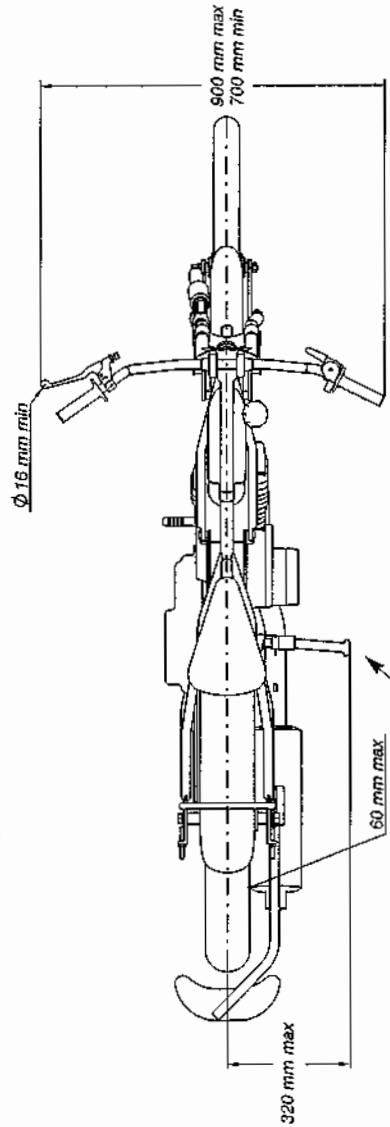
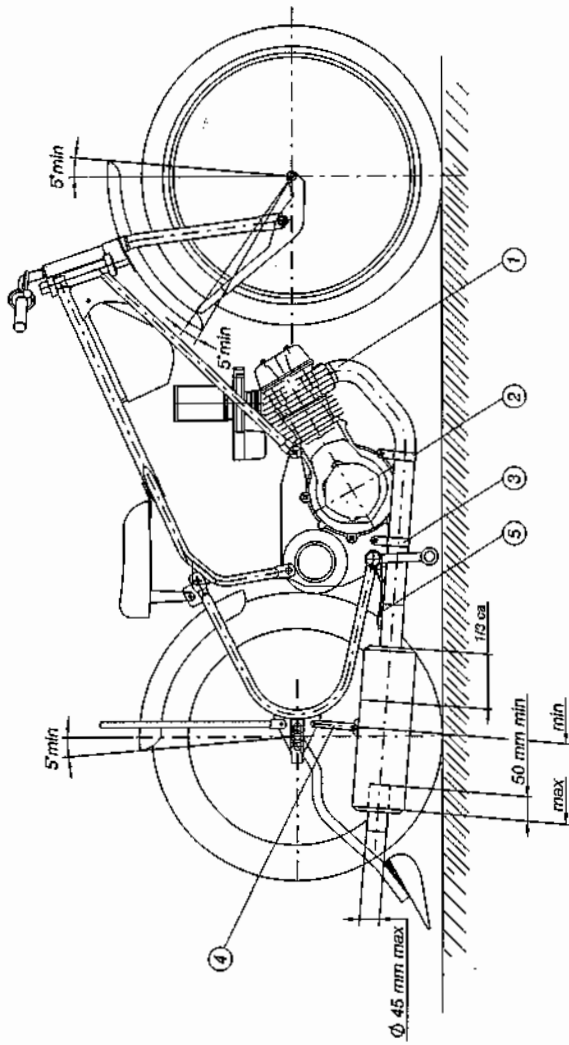

FOOTRESTS REPOSE-PIED

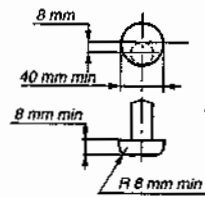

G Speedway

CHAIN GUARD GARDE-CHAÎNE

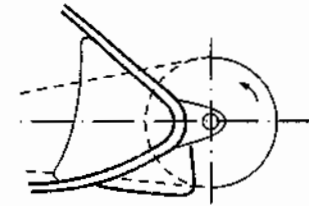

OPEN TRANSMISSION GUARDS GARDE-CHAÎNE OUVERTE

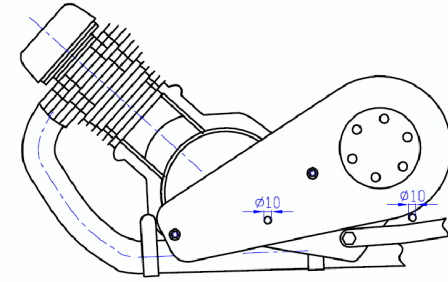

CARBURETTOR SECTION PLAN CARBURATEUR

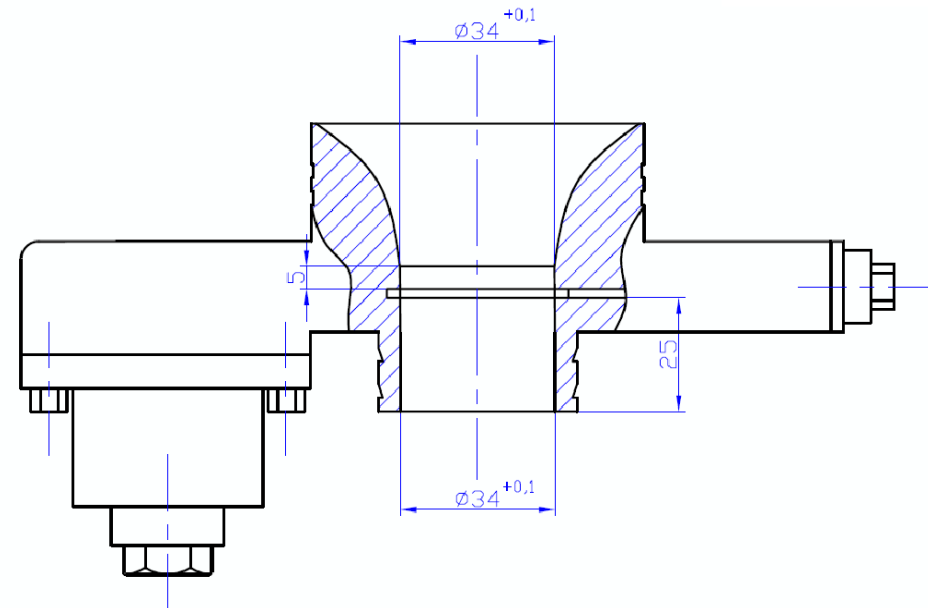

ICE / GLACE

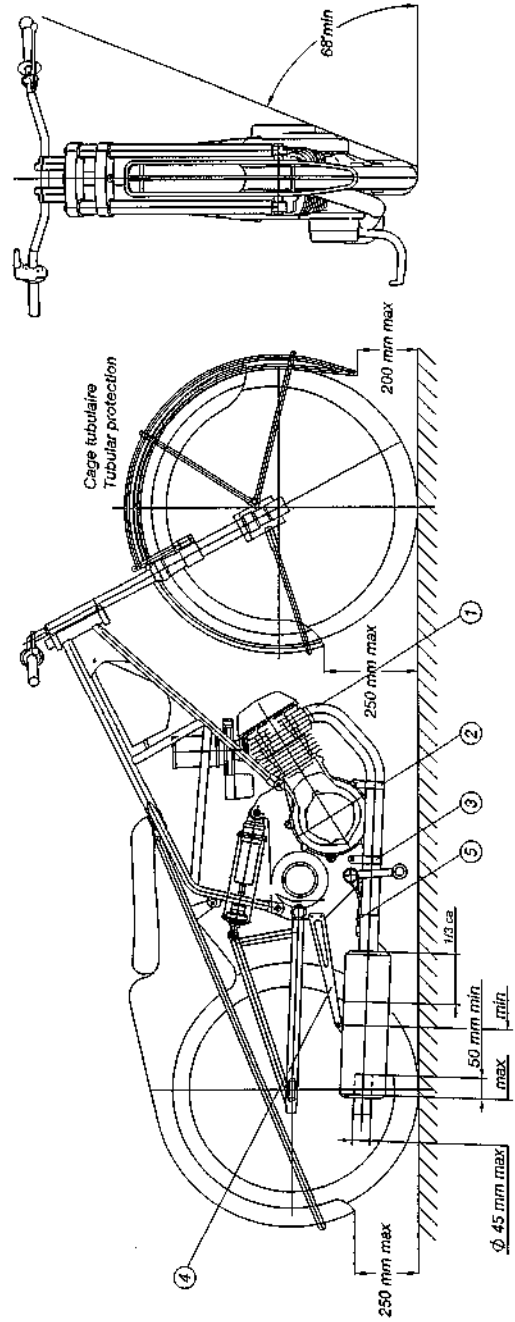

FOOTRESTS REPOSE-PIED

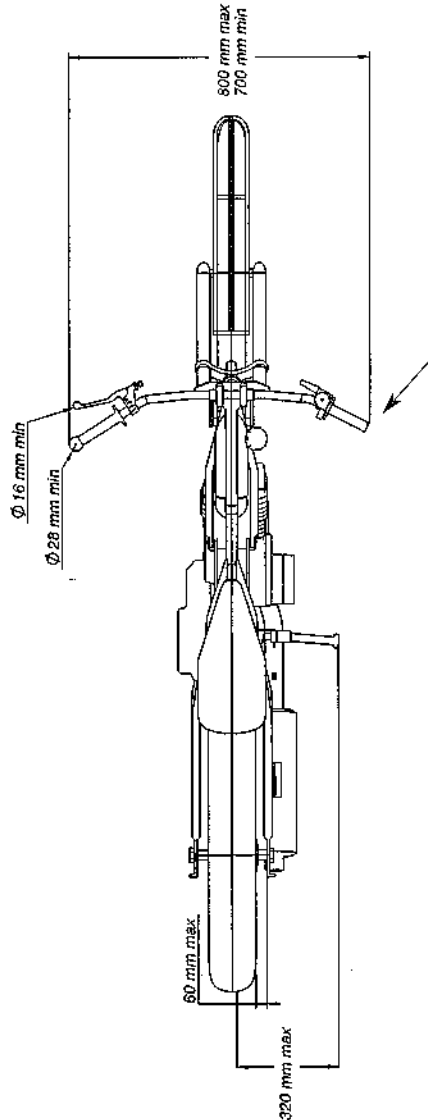
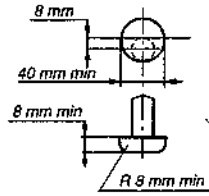

H

ICE / GLACE

CARBURETTOR SECTION PLAN CARBURATEUR

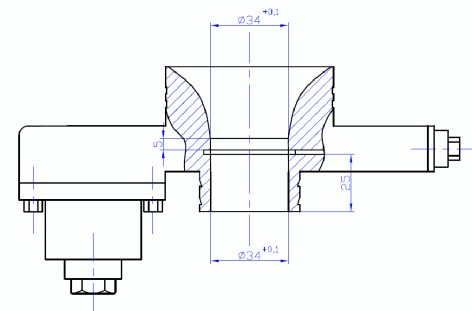

CLEARANCE

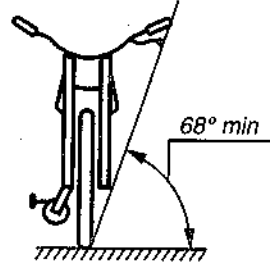

OPEN TRANSMISSION GUARDS

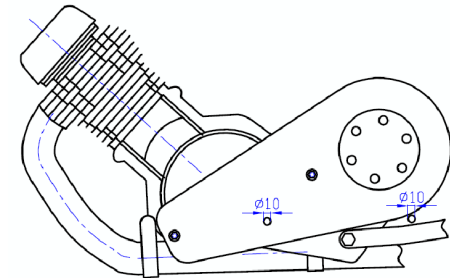

REAR WHEEL PROTECTION ROUE ARRIERE

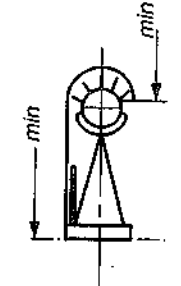

ICE SPEEDWAY SPIKES

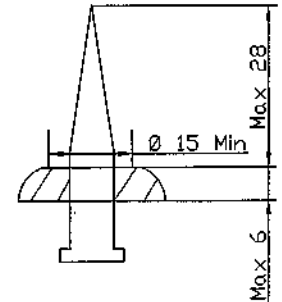

NEW ICE SPIKES DRW

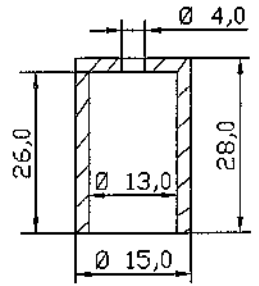

SPIKE GAUGE

H

LONG / LONGUE

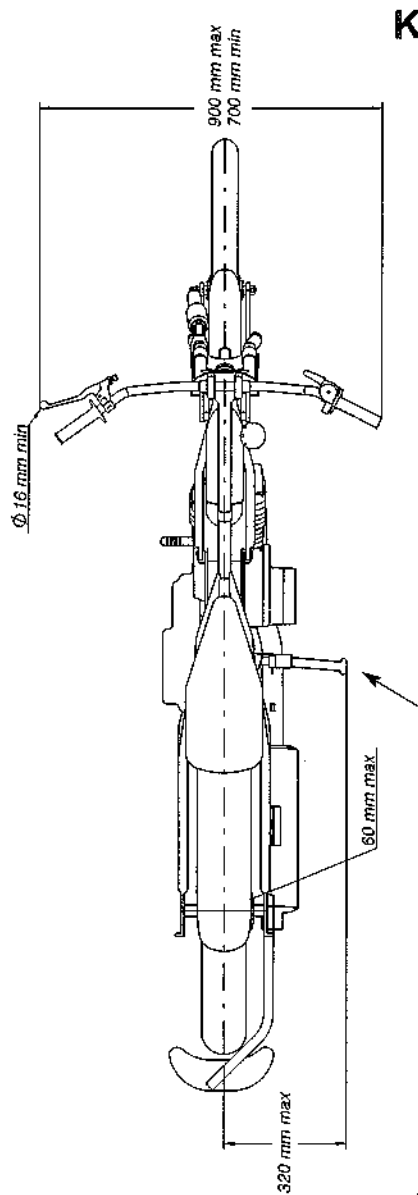
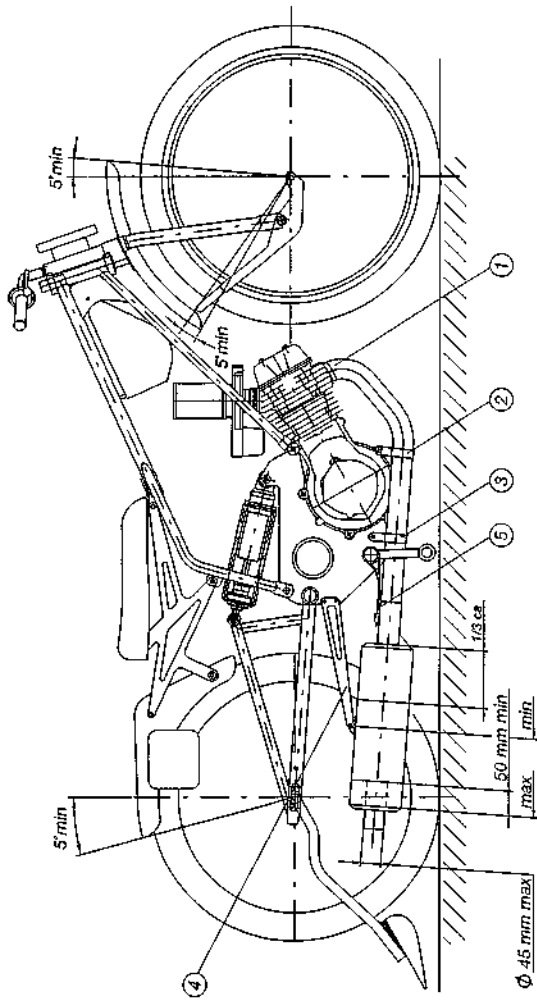

**FOOTRESTS
REPOSE-PIED**

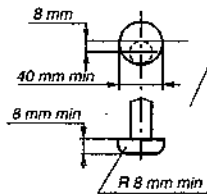

K

LONG / LONGUE

**OPEN TRANSMISSION GUARDS
GARDE-CHAÎNE OUVERTE**

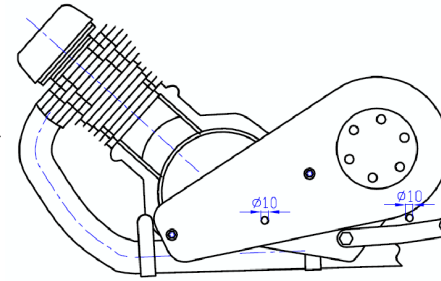

**CHAIN GUARD
GARDE-CHAÎNE**

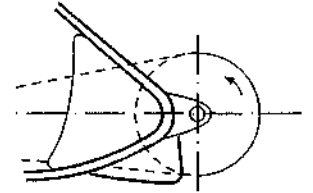

**CARBURETTOR SECTION
PLAN CARBURATEUR**

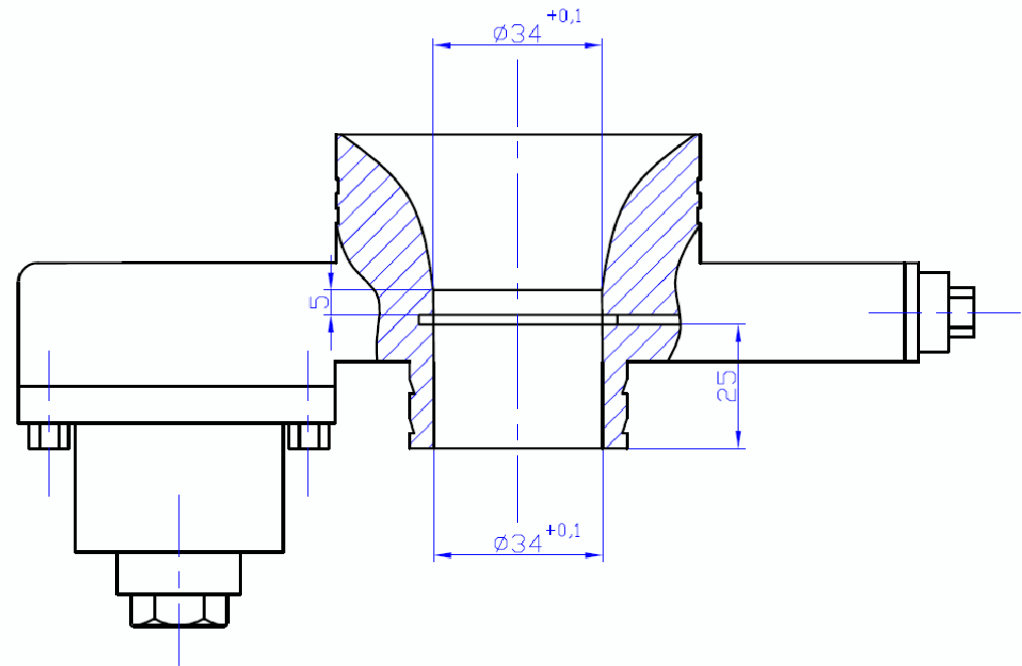

TRACK / PISTE SIDECAR

(voir / see art. 01.53)

L

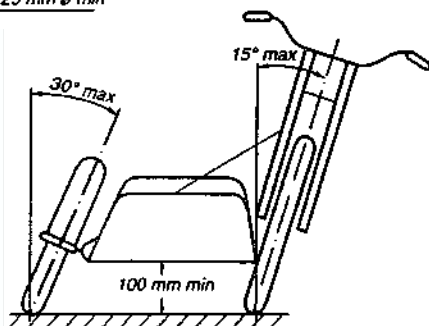
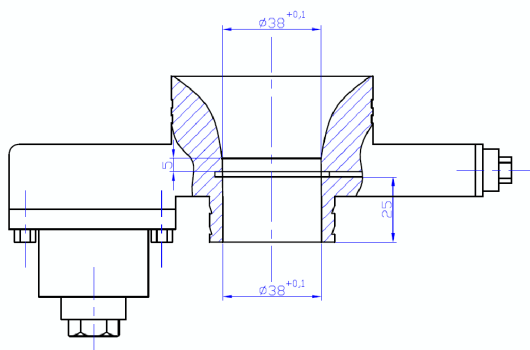
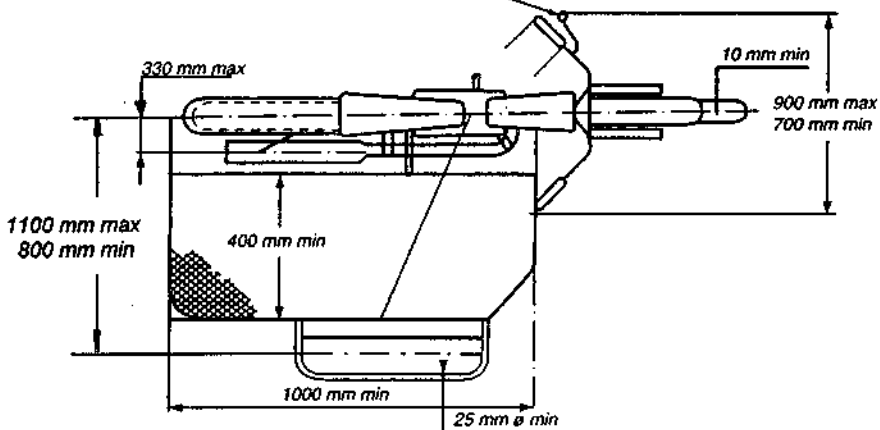
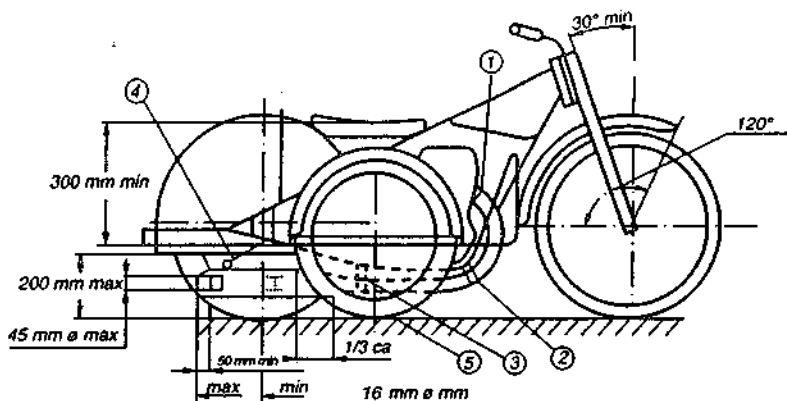

DIRT DEFLECTOR / DEFLECTEUR ANTI-PROJECTION

ART. 58.03

S

ART. 01.31

P

SPACE TO DEFLECTOR CLEARANCE / INSTALLATION ANGLE
ESPACE ENTRE LE PNEU ET LE DEFLECTEUR / ANGLE DE MONTAGE

Dirt deflector
FIM article 58.03

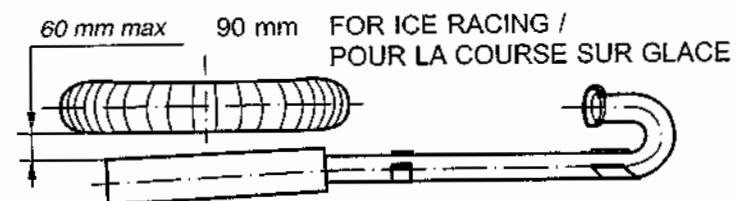
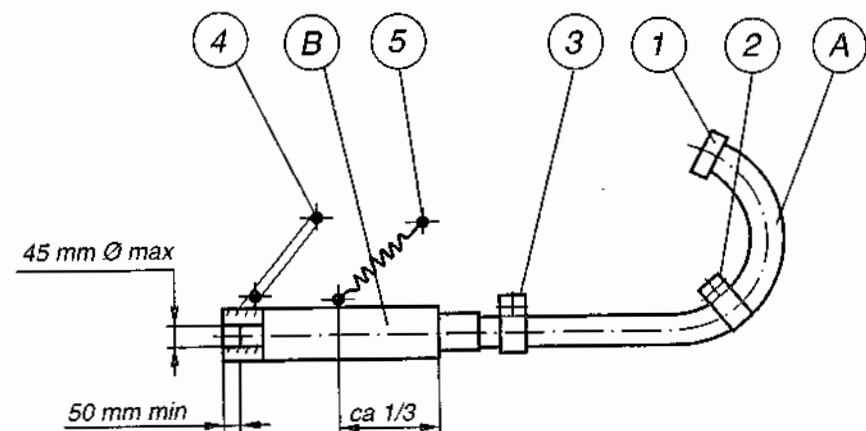
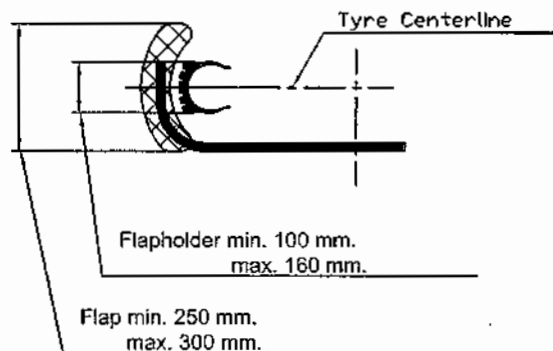
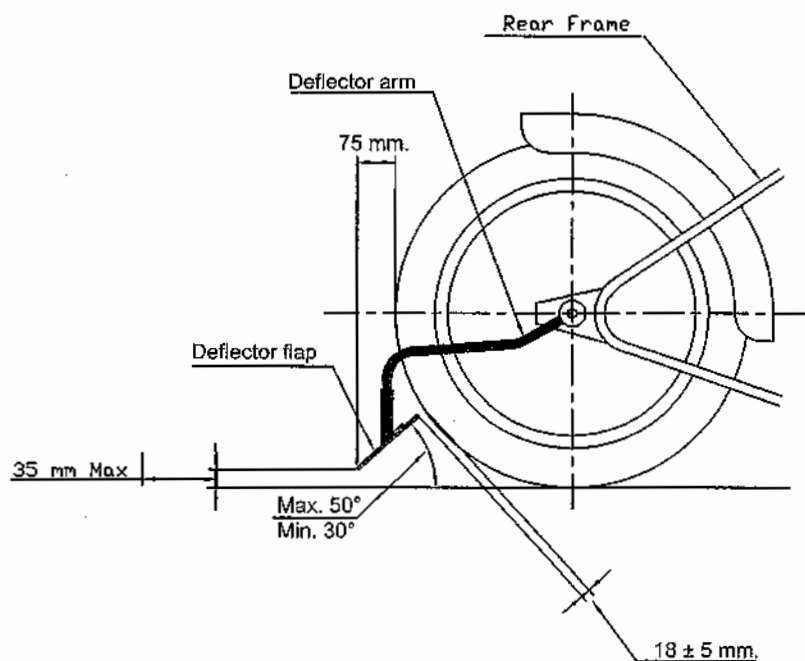

A = Exhaust Pipe (tuyau d'échappement)

B = Silencer (silencieux)

Sidecar Wheel Carrier

Diagram 1

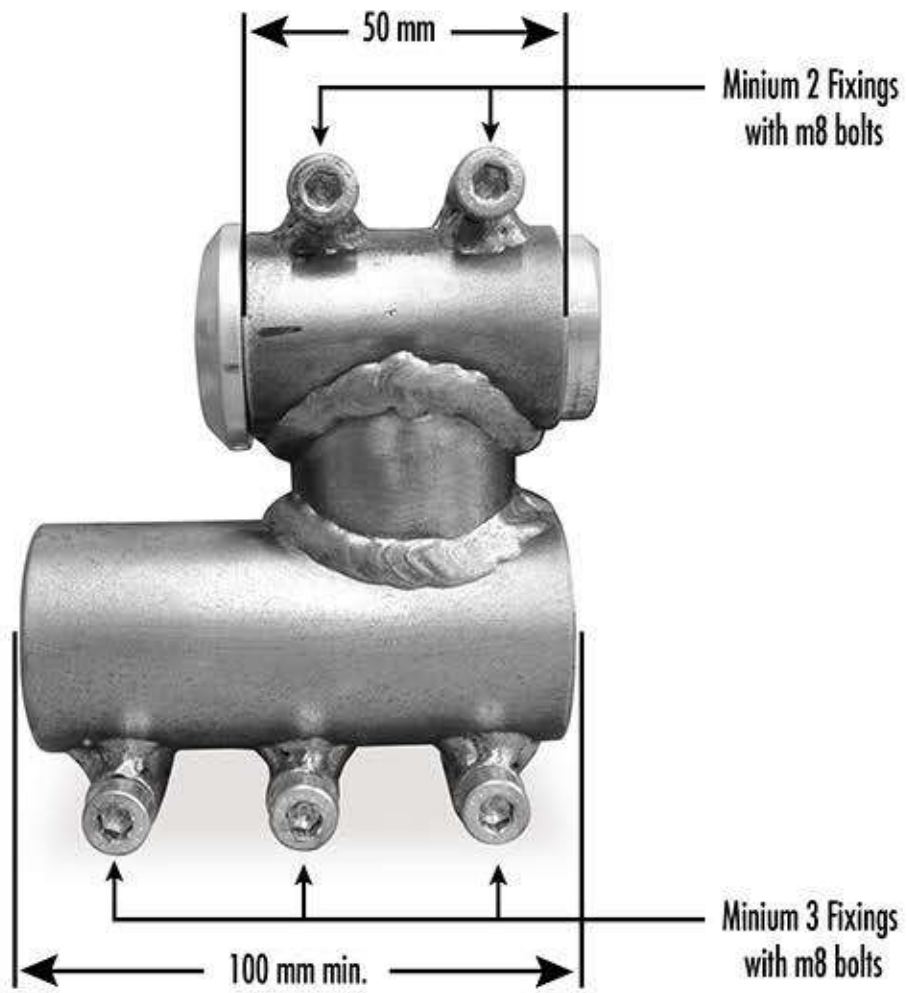
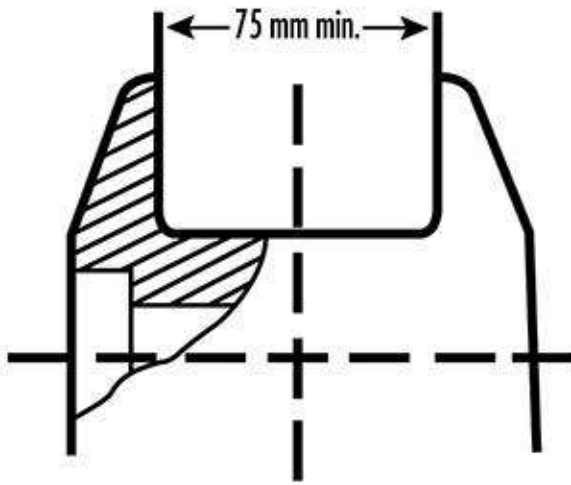

Sidecar Wheel Spindle

Diagram 2

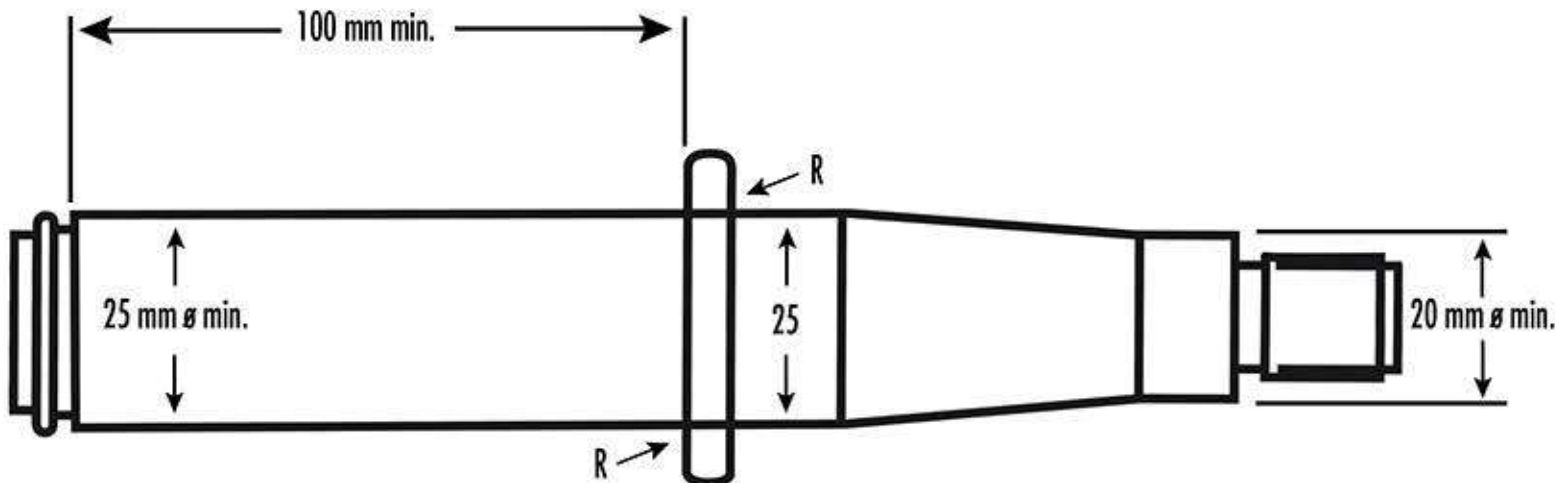
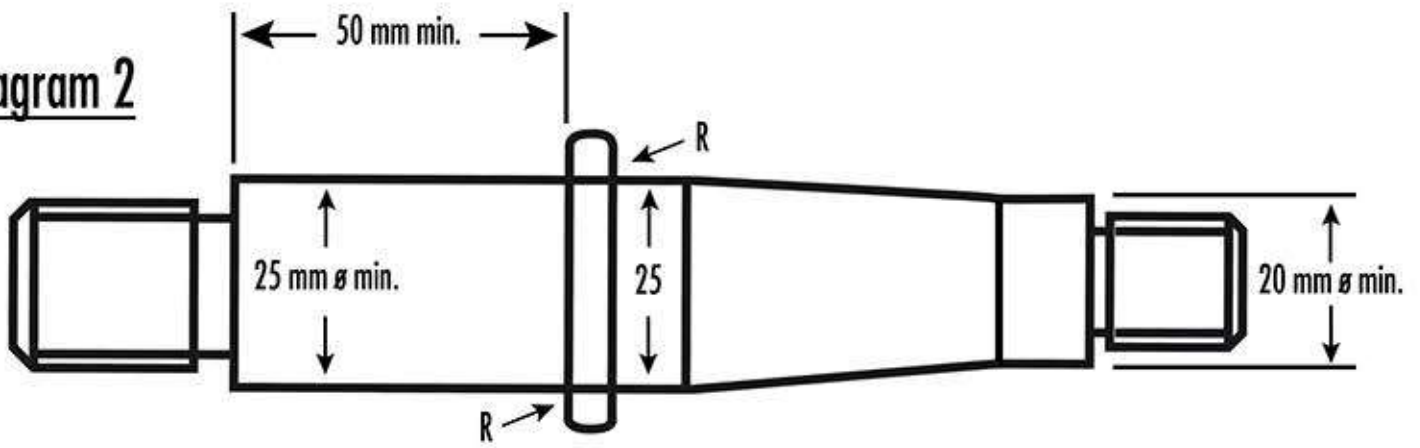

500cc Sidecar

Diagram 3

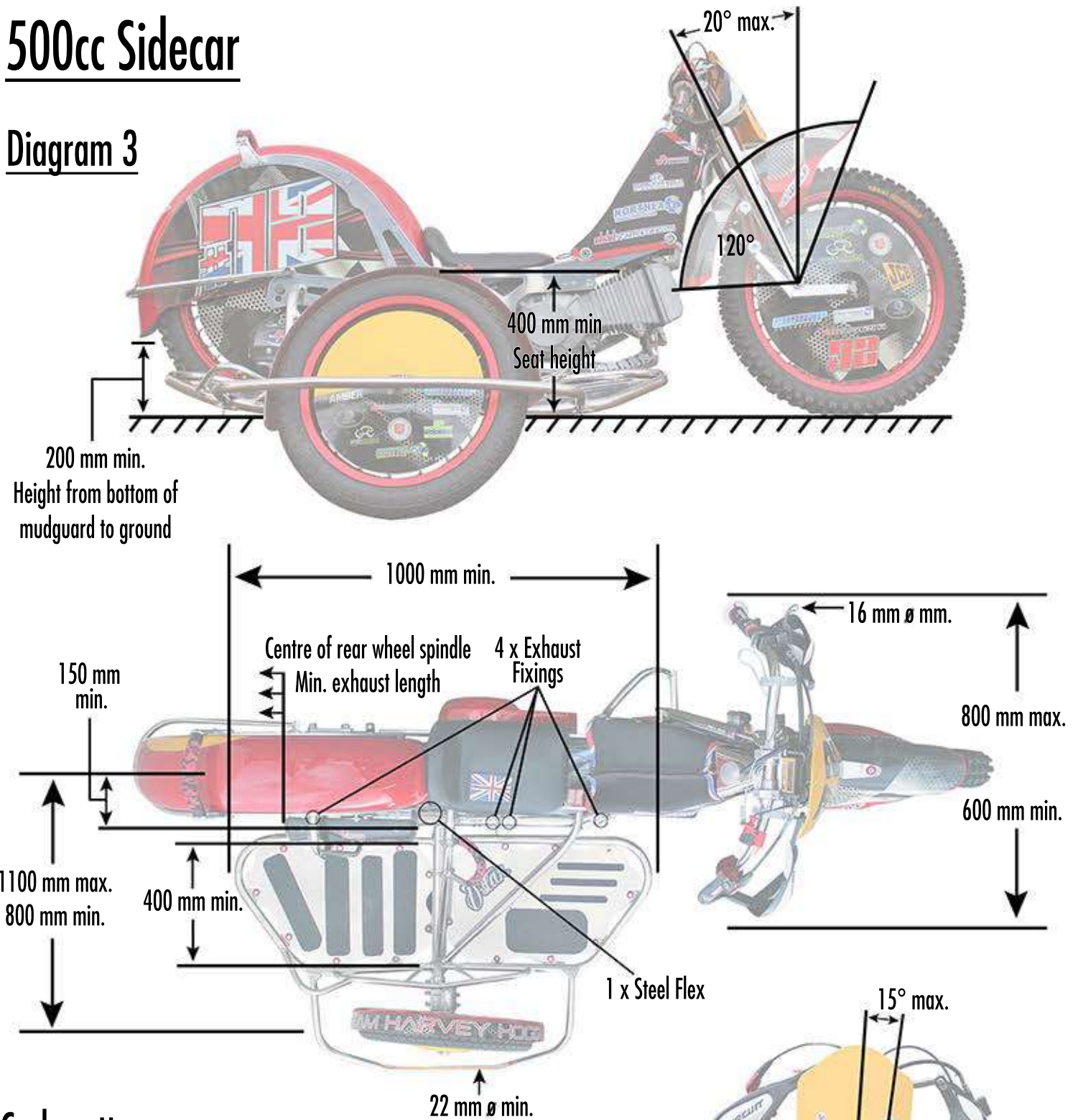

Carburettor

Diagram 4

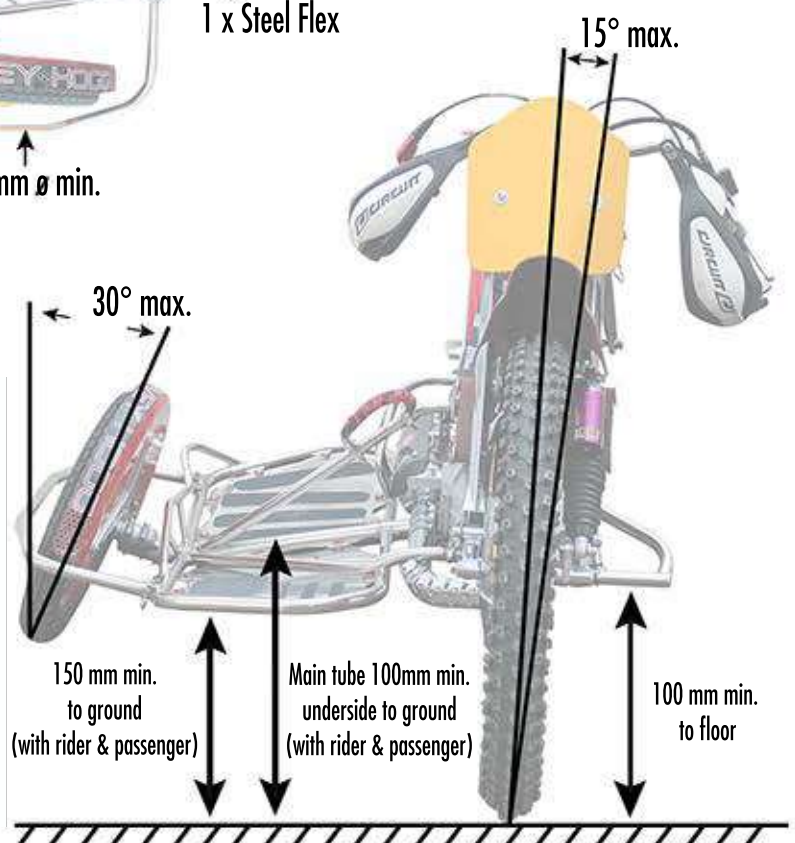
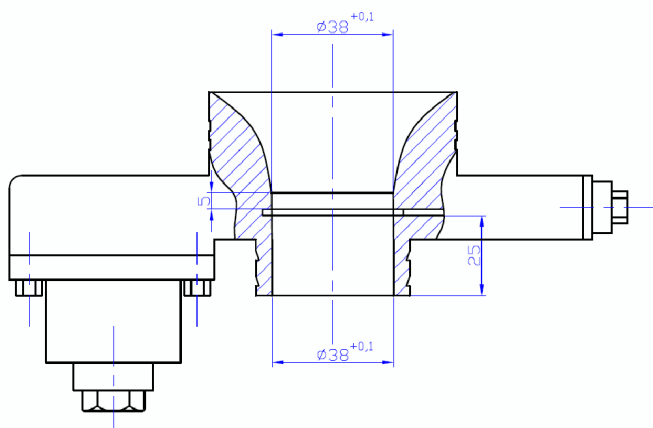

NUMBERS / NUMEROS

0

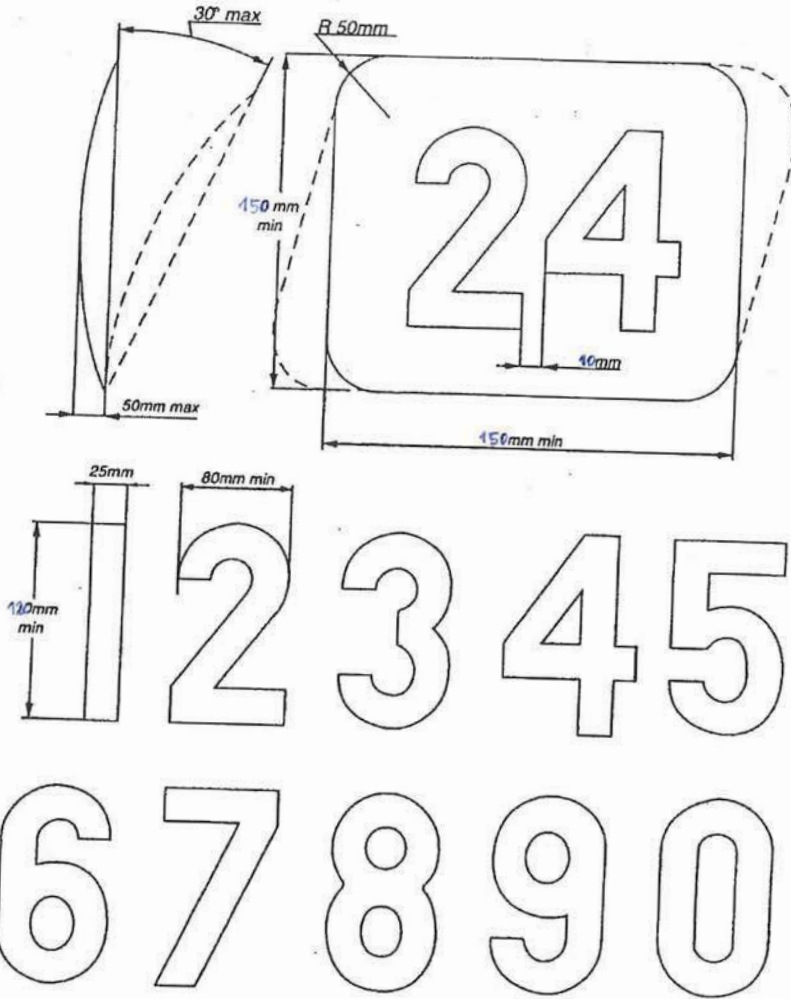

HELMET COLOUR DIAGRAM

A

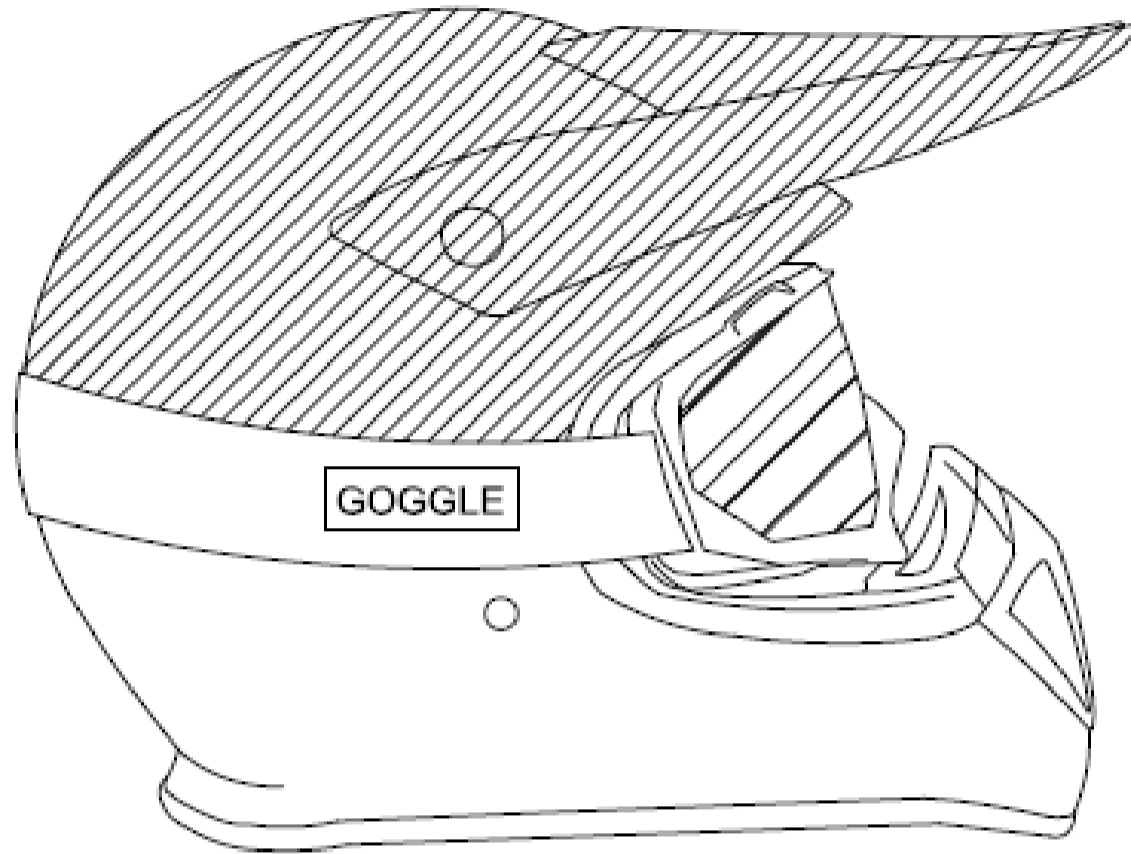

B

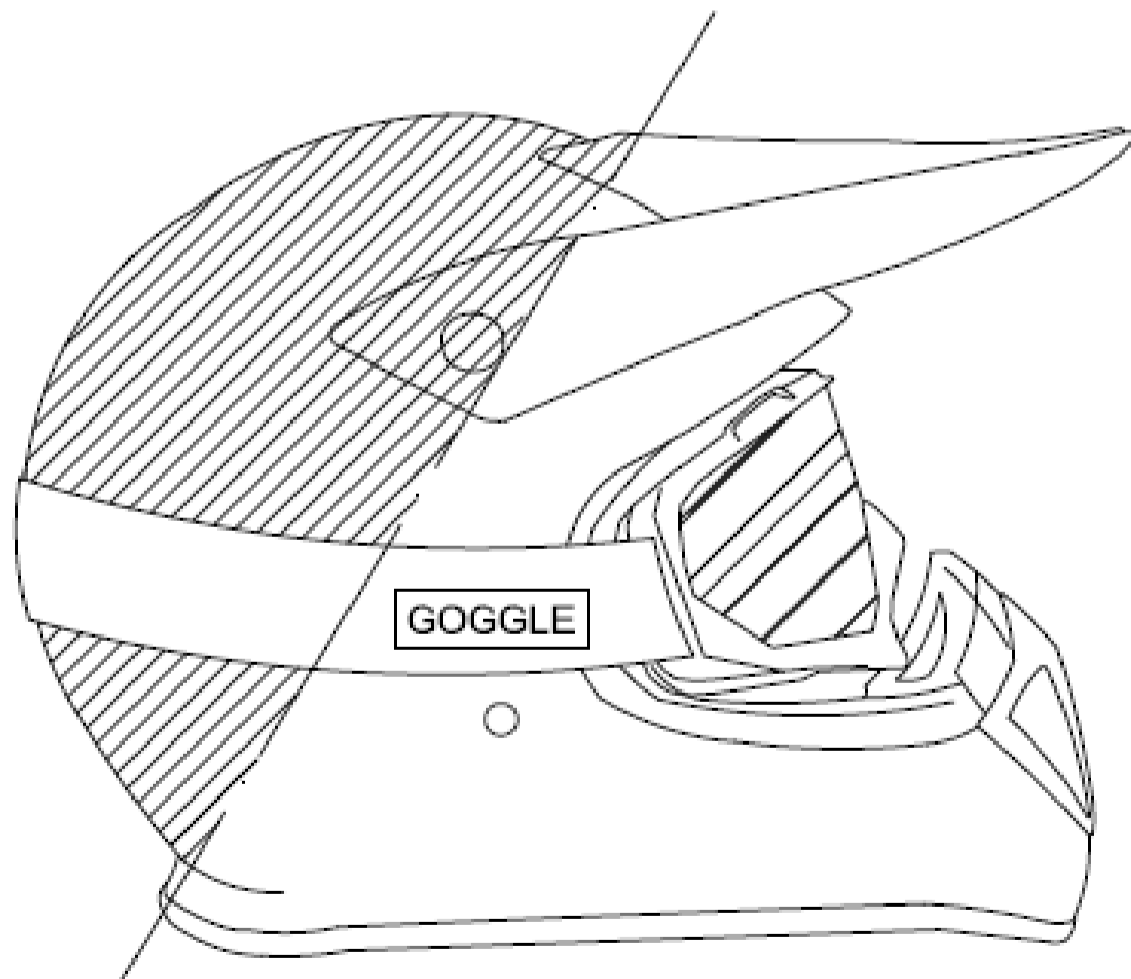

TEN FITTING TESTS FOR HELMETS
DIX TESTS D'ADAPTATION POUR LES CASQUES

1. *Obtain correct size by measuring the crown of the head*
Avoir la bonne grandeur en mesurant le sommet de la tête
2. *Check there is no side to side movement*
Vérifier qu'il n'y ait pas de déplacement d'un côté à l'autre
3. *Tighten strap securely*
Serrer solidement la jugulaire
4. *With head forward, attempt to pull up back of helmet to ensure helmet cannot be removed this way*
Tête en avant, essayer de soulever le casque pour s'assurer qu'il ne peut pas être enlevé de cette façon



5. *Check ability to see clearly over shoulder*
Vérifier si vous pouvez voir clairement par-dessus l'épaule
6. *Make sure nothing impedes your breathing in the helmet and never cover your nose or mouth*
S'assurer que rien ne gêne votre respiration dans le casque et ne jamais couvrir le nez ou la bouche
7. *Never wind scarf around neck so that air is stopped from entering the helmet. Never wear scarf under the retention strap*
Ne jamais enrouler une écharpe autour du cou, car cela empêche l'air d'entrer dans le casque. Ne jamais porter d'écharpe sous la jugulaire
8. *Ensure that visor can be opened with one gloved hand*
S'assurer que la visière peut être ouverte avec une main gantée
9. *Satisfy yourself that the back of your helmet is designed to protect your neck*
S'assurer que l'arrière de votre casque a une forme telle qu'il vous protège la nuque
10. *Always buy the best you can afford*
Toujours acheter le meilleur que vous pouvez vous offrir

FIM Track Racing Commission

Technical Control and verification during and after the Event / Contrôle Technique et vérifications Pendant et après la Manifestation

Titre de la manifestation / Title of the Meeting:

IMN:

Discipline / Disciplin:

Date:

Chef Contrôle Technique:

Licence N°

FMNR:

Chief Technical Steward:

Lieu / Venue:

Rider's name & first name	Contrôle poids Kg: Weight at random Kg:	N° de la course: Heat No :	Cylindrée moteur: Engine Capacity:	Diam. d'alésage: Bore Dia.:	Course du piston: Stroke:	Volume: cc	Signature du coureur Rider's signature

“FIM Fuels Regulation_TRACK RACING_2022_2”

01.63 METHANOL, GASOLINE AND LUBRICANT

The fuels that can be used for competition are listed in the table below:

	Pure methanol	Unleaded gasoline	Mixture of unleaded gasoline	Mixture of unleaded gasoline(s) and lubricant
Speedway 250cc – 500cc	✓			
Long Track 250cc – 500cc	✓			
Side car 500 cc	✓			
Flat Track		✓	✓	✓
All other engines	✓	✓	✓	✓

The unleaded gasoline or the mixture of unleaded gasolines used must comply with the FIM specifications as set out in Art. 63.01.

The mixture of unleaded gasoline(s) and lubricant must comply with the FIM specifications as set out in Art. 63.02.

Riders/teams must declare to the FIM Technical Director (or the FMNR Chief Technical Steward when there is no FIM Technical Director appointed) the make and type of gasoline to be used during practices and race(s), upon presentation of the rider/team's motorcycle(s) at the initial Technical Verifications. They are also recommended to provide a certificate issued by the gasoline company which certify that the gasoline has been tested and is in conformity with FIM specifications.

Gasoline companies which supply 'race' gasolines (gasolines other than those obtained at public pump stations) to participating teams/riders must test their gasoline at Intertek Schlieren (Switzerland) against all the FIM specifications set out in Art. 63.01.

Providing the gasoline is within the FIM specifications, a certificate containing a test report and batch number will be issued to the fuel company.

The gasoline company shall be able to provide a copy of such certificate to their client rider/teams before they take part in a race.

Contact for fuel analysis: fimfuels@intertek.com.

A list of gasolines which are in conformity with FIM specifications will be published by FIM on the FIM website.

Furthermore, in the cases in which only gasoline from the appointed supplier is permitted (for a specific event or the entire World Championship, Prize or Cup), the aforementioned gasoline shall have been previously tested in a FIM appointed

laboratory in order to test its conformity with the FIM specifications as set out in Art. 63.01:

- in case of conformity, a certificate of conformity (including test report and tested batch number) shall be available and Art. 01.63 applies in case of controls for the riders/teams;
- in case the conformity is not achieved, the FMN of the organising country/the Organiser/the Promoter shall ask the FIM for a waiver in order to enable the use of gasoline not corresponding to FIM specifications. If the waiver is granted, the riders/teams will be responsible for using the gasoline provided without changing its composition. Controls may be carried out by FIM.

63.01 FIM specifications for **methanol**, unleaded gasolines or mixtures of unleaded gasolines

The following specifications are set for **methanol**, unleaded gasoline or the mixture of unleaded gasolines:

- a) The following properties shall be within the following thresholds (for each property, the relative test methods to be used for the measurement are indicated):

Property	Units	Min.*	Max.*	Test Method
RON		95.0	102.0	EN ISO 5164 or ASTM D2699
MON		85.0	90.0	EN ISO 5163 or ASTM D2700
Oxygen (includes 10% ethanol allowance)	% (m/m)		3.7	EN ISO 22854 ¹ or EN 13132 or elemental analysis
Nitrogen	% (m/m)		0.2	ASTM D 4629 ² or ASTM 5762
Benzene	% (V/V)		1.0	EN ISO 22854 or ASTM D6839 or ASTM D5580
Vapour pressure (DVPE)	kPa		100.0	EN 13016-1 or ASTM D5191
Lead	mg/L		5.0	ICP-OES or AAS
Manganese	mg/L		2.0	ICP-OES or AAS
Density at 15°C	kg/m ³	720.0	785.0	EN ISO 12185 or ASTM D4052
Oxidation stability	minutes	360		EN ISO 7536 or ASTM D525
Sulphur	mg/kg		10.0	EN ISO 20846 or ASTM D5453
<u>Distillation:</u>				EN ISO 3405 or ASTM D86
E at 70°C	% (V/V)	20.0	52.0	

E at 100°C	% (V/V)	46.0	72.0	
E at 150°C	% (V/V)	75.0		
Final Boiling Point	°C		210	
Residue	% (V/V)		2.0	
Appearance	clear, bright and visually free from solid matter and undissolved water			Visual inspection
Olefins	% (V/V)		18.0	EN ISO 22854 or ASTM D6839
Aromatics	% (V/V)		35.0	EN ISO 22854 or ASTM D6839
Total diolefins	% (m/m)		1.0	GC-MS or HPLC
<u>Oxygenates:</u>				EN ISO 22854 ¹ or EN 13132
Methanol	% (V/V)		3.0	The only oxygenates permitted are paraffinic mono-alcohols and paraffinic mono-ethers (of 5 or more carbon atoms per molecule) with a final boiling point below 210°C.
Ethanol	% (V/V)		10.0	
Isopropanol	% (V/V)		12.0	
Isobutanol	% (V/V)		15.0	
<i>tert</i> -Butanol	% (V/V)		15.0	
Ethers (C5 or higher)	% (V/V)		22.0	
Others	% (V/V)		15.0	

¹ In cases of dispute EN ISO 22854 will be the reference method.

² In cases of dispute ASTM D 4629 will be the reference method.

*All reported min. and max. thresholds do not include the tolerance, which needs to be calculated in accordance with ISO 4259 and taken into account to correct the min. and max. thresholds.

- b) The total of individual hydrocarbon components present at concentrations of less than 5% (m/m) must constitute at least 30% (m/m) of the fuel. The test method will be GC-FID (gas chromatography-flame ionisation detector) and/or GC-MS (gas chromatography-mass spectrometry).
- c) The total concentration of naphthenes, olefins and aromatics classified by carbon number must not exceed the values given in the following table:

% (m/m)	C4	C5	C6	C7	C8	C9+
Naphthenes	0	5	10	10	10	10
Olefins	5	20	20	15	10	10
Aromatics	-	-	1.2	35	35	30

Bicyclic and polycyclic olefins are not permitted. The fuel must contain no substances which are capable of exothermic reaction in absence of external oxygen.

63.02 FIM specifications for mixtures of unleaded gasoline(s) and lubricant

The lubricant

- must not change the composition of the gasoline fraction when added to the gasoline;
- must not contain any nitro-compounds, peroxides or any other engine power boosting additives;
- must in no way contribute to an improvement in overall performance;
- during the distillation up to 250°C, must not show a reduction in mass by evaporation of more than 10% (m/m) (test method: simulated distillation GC);
- must contain a max. content of anti-knock agents (lead, manganese, iron) of 10 mg/Kg (test method: ICP-OES).

Moreover, the following specifications are set for the mixture of unleaded gasoline(s) and lubricant:

- a) The following properties shall be within the following thresholds (for each property, the relative test methods to be used for the measurement are indicated):

Property	Unit	Min.	Max.	Test Method
RON			102.0*	EN ISO 5164 or ASTM D2699
MON			90.0*	EN ISO 5163 or ASTM D2700
Density at 15°C	kg/m ³	690**	815**	EN ISO 12185 or ASTM D4052

*Reported min. and max. thresholds do not include the tolerance, which needs to be calculated in accordance with ISO 4259 and taken into account to correct the min. and max. thresholds.

** Min. and max. thresholds do include the tolerance.

63.03 Air

Only ambient air may be mixed with the fuel as an oxidant.

63.05 Sampling and Testing

The FIM may require gasoline controls, i.e. controls of the unleaded gasoline, mixture of unleaded gasolines or mixture of unleaded gasoline and lubricant, used by riders/teams at events.

Samples will be taken at any place and any time during the event (at the discretion of the FIM Technical Director).

The samples will be tested either:

- a) At the event using the methanol tester method.**
- b) Delivered by FIM courier to the FIM appointed laboratory for post event tests.**

63.05.01 Sampling

Procedure A: FIM methanol sampling for methanol testing method at the event (when available, if not procedure B applies).

- 1) The FIM Technical Director (or the FMNR Chief Technical Steward when there is no FIM Technical Director appointed) is the sole official responsible for the sampling management and supervision.
- 2) Riders/teams selected for methanol controls are directed to proceed with their vehicles to the area that has been designated for this purpose.
- 3) The FIM Technical Director/FMNR Chief Technical Steward collects the methanol from the motorcycle by using a methanol tester (electronic density meter DMA 35).

During the total duration of this Procedure, the motorcycle must remain in the appointed test area.

There will be no protest available, only the option to immediately make a second test.

Procedure B: FIM methanol and gasoline sampling for FIM appointed laboratory testing method (if Procedure A not applicable or in case of appeal / protest about result of the Procedure A).

- 1) The FIM Technical Director (or the FMNR Chief Technical Steward when there is no FIM Technical Director appointed) is the sole official responsible for the sampling management and supervision.
- 2) Riders/teams selected for **methanol**/gasoline controls are directed to proceed with their vehicles to the area that has been designated for this purpose.
- 3) The FIM Technical Director/FMNR Chief Technical Steward collects the gasoline from the motorcycle by using only new sample containers and pipettes/hand pumps.
The gasoline is transferred through the use of the pipette/hand pump directly from the gasoline tank into three containers, denominated A, B and C. The containers are closed and sealed by the FIM Technical Director/FMNR Chief Technical Steward.
- 4) The FIM Technical Director/FMNR Chief Technical Steward fills in (in all its parts) and signs the Gasoline Sample Declaration Form (see 63.04.03). The rider or a team representative also signs this Form, after verifying that all the information is correct.
- 5) The FIM Technical Director/FMNR Chief Technical Steward prepares an appropriate shipping box containing the collected A, B and C samples and a copy of the respective, signed, Gasoline Sample Declaration Form. The box is then shipped to the FIM appointed laboratory by registered courier.

63.05.02 Testing

Procedure A: FIM methanol testing method at the event (when available, if not procedure B applies).

- 1) One or more properties to be checked (following the relevant testing method as per Art. 63.01 and 63.02) are set by the FIM for each selected rider/team.

“All **250cc - 500cc** Speedway **and** Long Track and Sidecar 500cc engines must use pure methanol as fuel.”

How pure is the methanol can be checked at the event itself using an electronic density meter DMA 35.

Sample testing procedure:

- Testing with neutral sample (water)
- Sample extraction from the common tank
- Sample taken directly from the fuel tank of the motorcycle tested – rider

Density of methanol depends on temperature, as can be seen in the diagram 1 below.

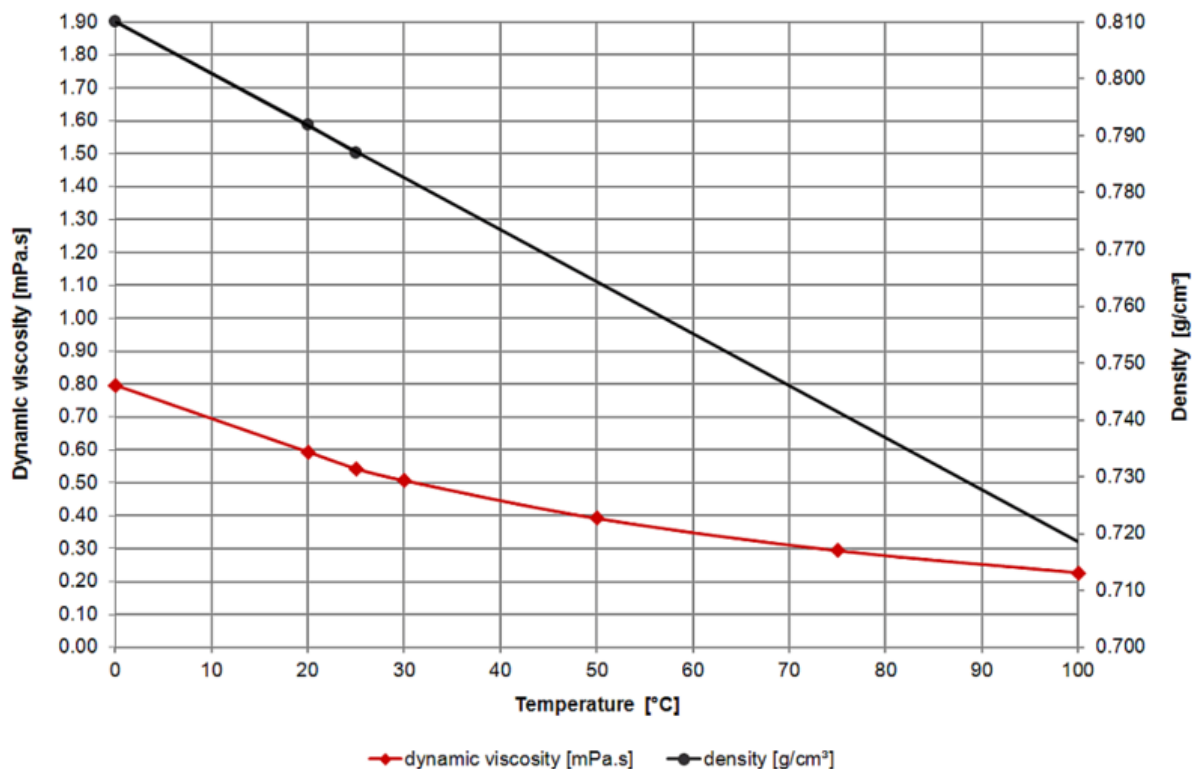
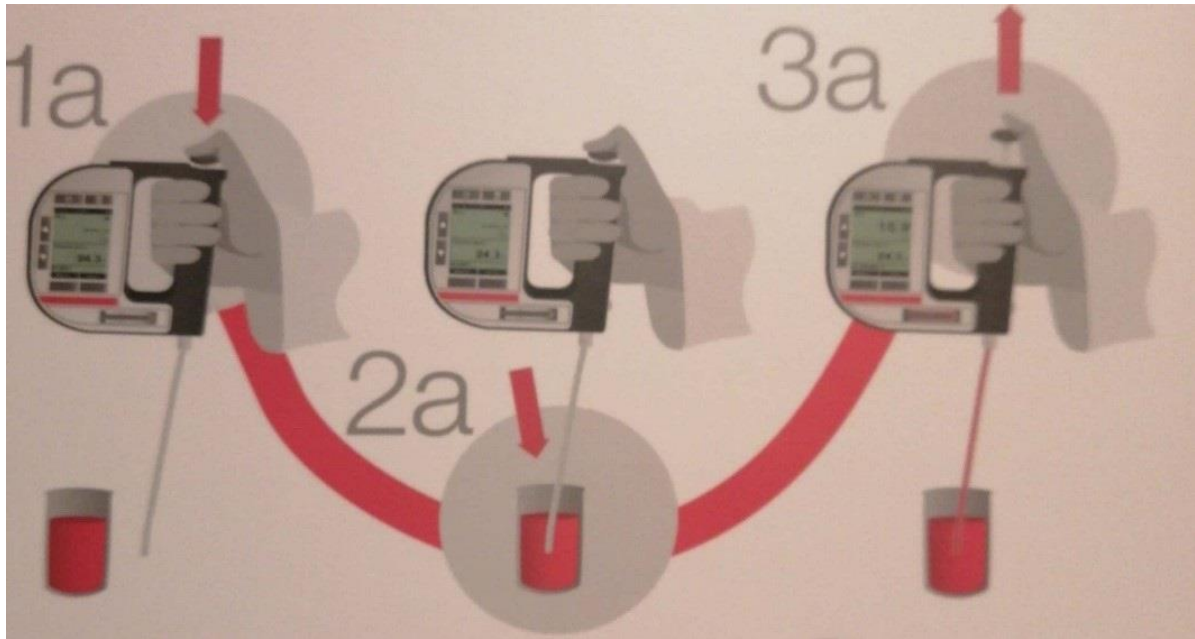

Diagram1, Methanol – dynamic viscosity and density over temperature

Measurement procedure (as shown on the diagram hereunder):

- (1a) Press the pump lever
- (2a) Sink the tube in the methanol sample (fuel tank of the motorcycle tested)
- (3a) Slowly release the pump lever
- Read the value



Credit picture: ANTON PAAR – DMA 35 – User manual illustration

- 1) **The threshold of result to pass the methanol test is fixed at 95% of match (compared with the same batch of methanol tested from the common tank (when provided by the promoter/organizer)).**
- 2) **Under 95% of match, the methanol test result is failed (meaning the methanol tested is not “pure” and is not in conformity with the methanol provided from the common tank (tested previously)).**
- 3) **The full procedure A can be made a second time upon request of the team manager/rider (of the team which the methanol is tested). The team manager/rider can attend to the full procedure.**
- 4) **In case of appeal/protest of the result of the Procedure A, the Procedure B will apply.**
- 5) **This result will be reported to the FIM International Jury which will take appropriate actions.**

Procedure B: FIM Fuel testing via FIM appointed laboratory (if Procedure A not available or in case of appeal/protest about result of the Procedure A).

- 1) One or more properties to be checked (following the relevant testing method as per Art. 63.01 and 63.02) are set by the FIM for each selected rider/team.
- 2) Sample A is the first sample to be tested by the FIM appointed laboratory.
- 3) Sample B can be used for a second analysis if required by the FIM. The test result of the A or B sample more favourable to the rider/team is taken into account. Costs for the shipping and testing of sample A and B are paid by FIM.

- 4) As soon as possible after completing the testing, the FIM appointed laboratory reports the test results directly to the responsible CTI Coordinator.
- 5) For negative cases (i.e. conformity of the tested property(ies) with the specification), the riders/teams concerned will be individually informed by the FIM in due course, copying the rider/team's FMN, the FIM Technical Director/FMNR Chief Technical Steward, the competent authority (e.g. Race Direction, International Jury), the CTI Director, the Director and Coordinator(s) of the sporting Commission concerned.
- 6) Only for positive cases following testing of sample A or B or A and B (i.e. non-conformity of one or more properties*), the responsible CTI Coordinator notifies by electronic mail* the rider/team concerned (including the testing results) and, 24 hours after, forwards the relevant information to the rider/team's FMN, the FIM Technical Director/FMNR Chief Technical Steward, the competent authority (e.g. Race Direction, International Jury), the CTI Director, the Director and Coordinator(s) of the sporting Commission concerned.
*Note: The non-conformity of one property (except the Appearance) is sufficient for declaring non-conformity of the gasoline or the mixture.
- 7) If the rider/team wishes to request a counter-expertise, he must notify the responsible CTI Coordinator by electronic mail* accordingly, within 72 hours of receipt by the FIM of the delivery status notification pertaining to the notification of the test results to the rider/team.
 - If a counter-expertise is requested, the sample dedicated to the counter-expertise is sample C and the test shall aim at checking the same property(ies) previously checked on sample A/B. The rider/team can request that sample C be tested at one of the available FIM appointed laboratories. Costs for shipping and testing of sample C are paid by the rider/team concerned.
Upon notification of the sample C results, the responsible CTI Coordinator notifies by electronic mail* the rider/team concerned (including the testing results) and forwards the relevant information to the rider/team's FMN, the FIM Technical Director/FMNR Chief Technical Steward, the competent authority (e.g. Race Direction, International Jury), the CTI Director, the Director and Coordinator(s) of the sporting Commission concerned.
 - If no counter-expertise is requested within the time limit, the responsible CTI Coordinator forwards the relevant information by electronic mail* the rider/team's FMN, the FIM Technical Director/FMNR Chief Technical Steward, the competent authority (e.g. Race Direction, International Jury), the CTI Director, Director and Coordinator(s) of the sporting Commission concerned.
- 8) The competent authority of the event concerned (e.g. Race Direction, International Jury) takes a decision based on the information received. The

Coordinator of the sporting Commission concerned notifies the rider/team concerned regarding the decision by electronic mail*.

The non-conformity of

- A sample (in the cases B sample was not used) or
- B sample (in the cases A sample result was not conclusive) or
- A and B samples or
- A and B and C samples (in the cases B sample was used and a counter-expertise was requested) or
- A and C samples (in the cases B sample was not used and a counter-expertise was requested) automatically results in the disqualification of the rider/team from the entire event.

No disqualification will be applied in case of conformity of sample C.

Furthermore, in any case, other penalties may be applied.

- 9) The rider/team has the right to appeal against the decision of competent authority of the event concerned (e.g. Race Direction, International Jury) in accordance with FIM Disciplinary and Arbitration Code applicable to the relevant discipline.

*The receipt of a delivery status notification will be deemed as proof of delivery.

63.05.03 Gasoline Sample Declaration Form

 FIM WORLD CHAMPIONSHIPS, CUPS AND PRIZE EVENTS Gasoline Sample Declaration Form									
Discipline									
IMN (xxx/xx)									
Rider/team's name									
Rider/team's number									
Rider/team's email or telephone number									
Team									
Vehicle's make									
Gasoline's make and type									
Gasoline origin (public station or race supplier)									
Gasoline samples taken on date (dd/mm/yy)									
Gasoline samples taken at (right before or right after): MOTOCROSS TRIAL TRACK RACING ENDURO/ISDE RALLIES/BAJAS <input type="checkbox"/> Practice <input type="checkbox"/> Day 1 <input type="checkbox"/> Heat n°__ <input type="checkbox"/> Day 1 <input type="checkbox"/> Day 1 <input type="checkbox"/> Qualifying race <input type="checkbox"/> Day 2 <input type="checkbox"/> Day 2 <input type="checkbox"/> Day 2 <input type="checkbox"/> Day 2 <input type="checkbox"/> Race 1 <input type="checkbox"/> Day n°__ <input type="checkbox"/> Day n°__ <input type="checkbox"/> Race 2									
	<table border="1"> <thead> <tr> <th></th> <th>Vial seal n°</th> </tr> </thead> <tbody> <tr> <td>Sample A</td> <td></td> </tr> <tr> <td>Sample B</td> <td></td> </tr> <tr> <td>Sample C</td> <td></td> </tr> </tbody> </table>		Vial seal n°	Sample A		Sample B		Sample C	
	Vial seal n°								
Sample A									
Sample B									
Sample C									
The above listed details refer to gasoline samples taken from the gasoline tank of the motorcycle specified. Sample A is the first testing sample to be used by the FIM appointed laboratory. Sample B can be used for a second analysis if required by the FIM. Sample C is used if a counter-expertise is required by the rider/team. The serial numbers of the vial seals and the accuracy of the listed information have been verified.									
Rider or team responsible name									
Rider or team responsible signature									
FIM Technical Director/FMNR Chief Technical Steward name									
FIM Technical Director/FMNR Chief Technical Steward signature									

“FIM Sound Regulation_TRACK RACING_2022_1”

01.79 SOUND LEVEL CONTROL - INTRODUCTION

NOTES:

- Sound test on homologated silencers (see Art. 01.31) is not applicable at the initial technical verifications.
- Sound test on non-homologated silencers is applicable at the initial technical verifications.
- Homologated silencers (as non-homologated silencers) can be subject to be tested at random during or at the end of an event.

In order to pursue the measures taken to reduce the sound level in favour of environment and in the framework of the ‘RIDE QUIET’ campaign, a new method for measuring the sound level called "2 metre max" is applied since 2013 in all ‘all-terrain’ disciplines.

Excessively loud machines must always be checked, regardless of the participants' status.

The technical specifications and the resources to apply such a method, for the use of the technical stewards and officials, are outlined in the present Article.

The "2 metre max" method shows a very good correlation between the sound power level (LwA) issued by motorcycles in full acceleration, and the maximum sound pressure levels measured at proximity of the same motorcycles, with engines at idle and quickly taken to their maximum rotational speeds.

The "2 metre max" method will consist in quantifying not only the sound level produced by the silencer of the exhaust, but the maximum global sound level achieved by the motorcycle when the engine rpm's are raised to the maximum engine speed, limited by a natural regulation (for 2 strokes) or rev limiters (for 4 strokes).

Only the sound levels measured with the "2 meter max" method will be considered by the technical stewards and by the Race Direction/Jury of the event to decide whether the motorcycle is in conformity with the maximum sound levels authorised.

For Motocross, Enduro/ISDE/SuperEnduro/HardEnduro:

Before the opening of the season, the manufacturers must declare to the FIM International Technical Commission (CTI) at cti@fim.ch the maximum power rpm value of the engine of their motorcycles (in standard ‘production’ specification as sold on the market). The minimum threshold of rpm applied for each class for the sound control procedure will be defined and communicated by the FIM Technical Director.

No modification (in any possible way) of the original RPM channel is allowed. During the sound control, the engine must be able to reach its maximum admissible RPM level (meaning at least the minimum rpm set for each class by the FIM Technical Director according to the information provided by the manufacturers) in Neutral or In Gear position of the gearbox (at the discretion of the Sound Control Officer (SCO)).

Furthermore, all systems as “home-made” dB-Killers (not delivered as original part or accessory of the silencer/exhaust line) are strictly forbidden. In case of dispute, the decision of the FIM Technical Director will be final.

79.01 Preparation of the sound meter

For all FIM championships and prizes, sound level meters must conform to the frequency response tolerance for Class 1 or Class 2 for nominal frequencies between 125Hz to 8000Hz, as stated by the IEC 61672-1:2013 subsection 5.5 standard.

All sound level meters must also conform to the tolerance for Class 1 or Class 2 for amplitude linearity, for its specified class, as stated by the IEC 61672-1:2013 subsection 5.6 standard. IEC 61672 is a regulatory document, which covers specifications and qualification requirements for class 1 and class 2 sound level meters.

~~For all FIM Championships and Prizes, all sound meters must have a frequency response According to IEC61672 Section 11 within a limit of plus or minus 2 [dB/A] from 125 to 8000 [Hz] at 94, 104 and 114 [dB/A].~~

Two sets of equipment must be available in case of failure of tachometer, sound level meter or calibrator during technical control.

Sound level measuring equipment must also include:

- a compatible calibrator, which must be used immediately before testing begins and always just prior to a re-test if a disciplinary sanction may be imposed;
- a tachometer.

The sound meter shall be prepared by applying the following procedure:

1. Activate the 'A' weighing
2. FAST time weighting must be activated
3. Select the highest range available (ex. 80~130 [dB])
4. Calibrate the sound meter according to the instructions, taking into account the incidence of the wind foam ball
5. Position the wind foam ball on the microphone
6. Activate the function MAX MIN – set on MAX

79.02 Set up of the **measurement sound meter and the motorcycle**

The sound levels will be measured with the microphone fixed on a tripod at a height of 1.35 m above the ground, in horizontal (levelled) position. It is helpful to have the microphone equipped with an extension cable to the sound meter.

For the place and position of the motorcycle, ensure that there are no solid obstacles within 10 m around the microphone.

Depending on the vehicle, the sound meter will be positioned:

for Solo motorcycles: at an angle of 45° from the longitudinal axis of the vehicle, on the exhaust side, at a distance of 2 m behind the vehicle (measured from the point where the centre of rear tyre touches the ground).

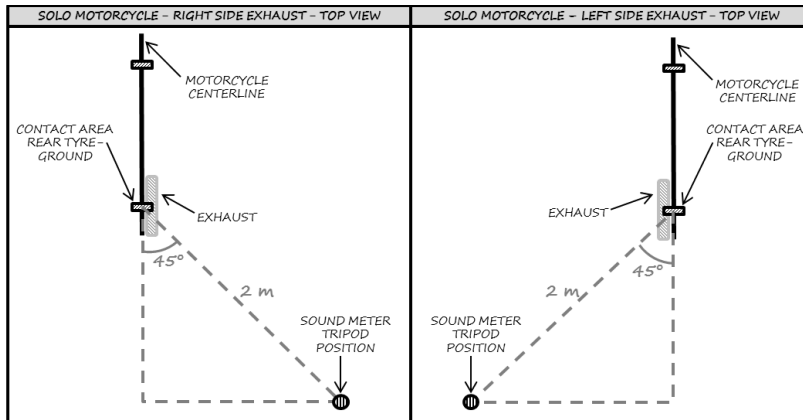

Figure 1 : Sound meter position for solo motorcycle

for Solo motorcycles with 2 exhaust outputs: at an angle of 45° from the longitudinal axis of the vehicle, on the side of the air intake, at a distance of 2 m behind the vehicle (measured from the point where the centre of rear tyre touches the ground). Note: if a central positioned air intake is used, both sides will be tested.

for Snowmobiles: at an angle of 90° from the longitudinal axis of the vehicle, on the side of the silencer, at a distance of 2 m next to the vehicle (measured from the silencer exit). For continuity of the measurement, use the handlebar as a reference to line up the machine with the microphone - the exhaust pipe is usually located on the right hand side of the machine and directly under the handlebar position. Note: the use of only one silencer is allowed for Snowmobiles.

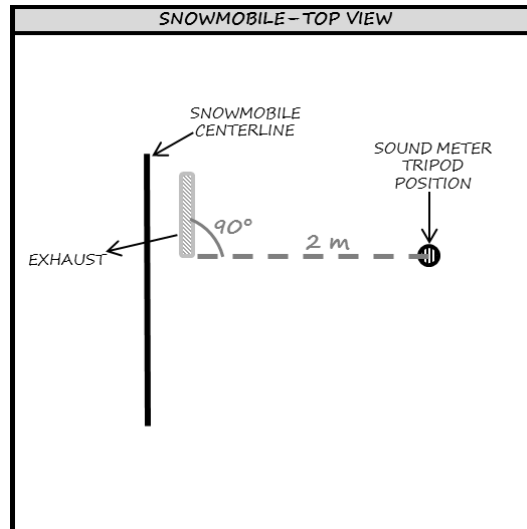

Figure 2: Sound meter position for solo snowmobile

for Sidecars: at an angle of 45° from the longitudinal axis of the vehicle, on the sidecar side, at a distance of 2 m behind the vehicle (measured from the point where the sidecar tyre touches the ground). If the exit of the silencer is closer to the motorcycle rear wheel, the reference point will be the contact point of the motorcycle rear wheel on the ground (as for Solo motorcycles).

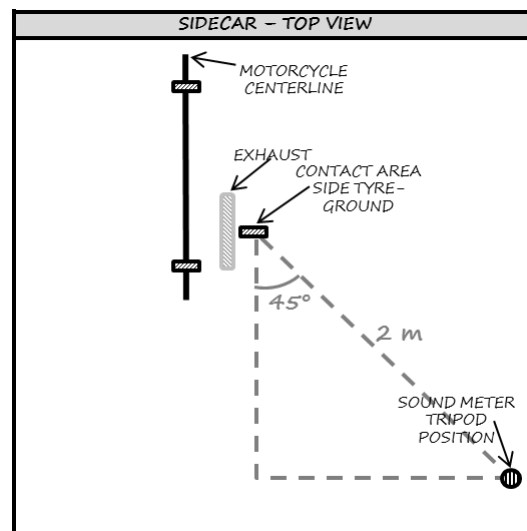

Figure 3: Sound meter position for sidecars

for Quads: at an angle of 45° from the median longitudinal axis of the vehicle, at a distance of 2 m behind the vehicle (measured from the point where the line drawn perpendicular to the rear axle touches the ground).

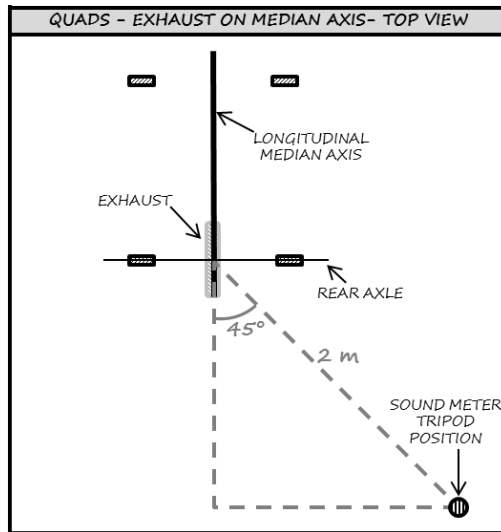

Figure 4: Sound meter position for quads

for Quads with the exhaust moved out of the median axis: at an angle of 45° from the exhaust axis, on the offset side, at a distance of 2 m behind the vehicle (measured from the point where the line drawn perpendicular to the rear axle touches the ground).

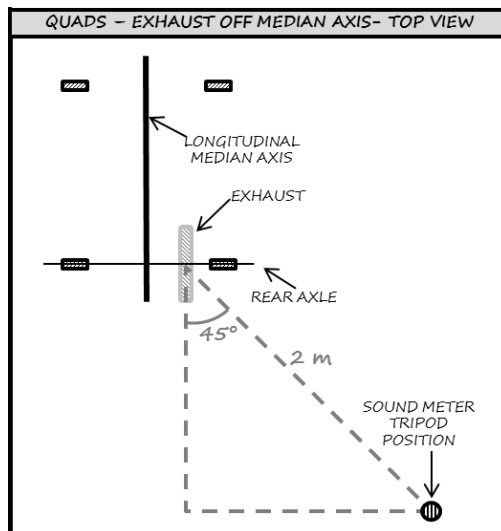

Figure 5: Sound meter position for solo motorcycle with exhaust moved out of the median axis

The sound level for engines with more than one silencer will be measured on each exhaust end.

Silencers fitted with adapters aiming to reduce the sound level shall be permanently fitted.

To make repetitive measurements, all motorcycles can be positioned into a small frame fixed on the ground, making sure to respect the 45° requirements. A squared frame helps the positioning of the motorcycle.

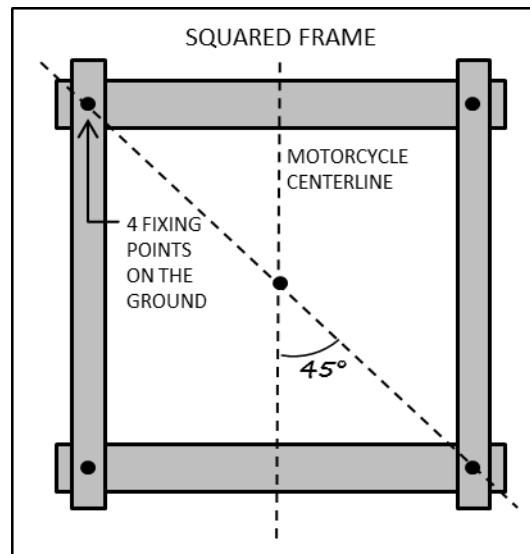

Figure 6 : Squared frame design

Vehicles which are not equipped with a gear box neutral must be placed on a stand.

It is preferred to make the tests on soft ground, not reverberating, i.e. grass or fine gravel.

In other than moderate wind, machines should face forward against the wind direction.

The ambient sound at the point of measurement must be minimum 15 [dB/A] less than the lowest FIM sound limit applied in each discipline.

Before starting measurements and before you put the system away unless there is an accident (physical impact to the equipment).

It is recommended to regularly re-calibrate the sound meter during the test day.

79.03 Test procedure

The Sound Control Officer (SCO, see 77.03) must be holder of a valid FIM Technical Stewards' license, come with good knowledge and experience of the sound control and application of the test method. The FMNR may propose the services from a special technician (acoustic engineer) if there is no FIM licenced Technical Steward available to act as SCO.

The SCO must have arrived in sufficient time for discussions with the Clerk of the Course/FIM Race Director and other Technical Officials in order that a suitable test site and testing procedure can be agreed. The SCO takes place next to the vehicle, opposite to the sound meter/microphone, in order not to screen or stand between the bike and the microphone.

A technical steward (nominated as Sound Control Officer, "SCO", see 77.03) takes place next to the vehicle, opposite to the sound meter/microphone, in order not to screen or stand between the bike and the microphone.

The Sound Control Officer (SCO) must have arrived in sufficient time for discussions with the Clerk of the Course/FIM Race Director and other Technical Officials in order that a suitable test site and testing procedure can be agreed.

A second technical steward can be present to help. The rider can also be present.

It is strongly advised that the technical steward(s) use earplugs, a headset or ear protectors.

The measurements **are** is made with motorcycle on its wheels, with a hot engine, **whatever in neutral gear position of in-gear position (at the discretion of the SCO)**. During the sound test, only the rider may sit on the vehicle in the normal riding position.

A rider or a mechanic, placed on the left side of the motorcycle, shall disengage the clutch.

The SCO (and not others) shall open the throttle as fast as possible (instantly, within 0.3 s) until "full open throttle", in order to reach the maximum rpm value ("max. rpm").

For Motocross, Enduro/ISDE/SuperEnduro/HardEnduro, Cross-country rallies/Bajas and Track Racing motorcycles with no FIM homologated silencers, the "max rpm" is the one defined by the ECU (for 4-stroke engines), or by a natural regulation (for 2-stroke engines).

When in doubt, it can be verified that such "max. rpm" value is higher than the rpm value at which the vehicle supplies its maximum power (kW) ("max. power rpm").

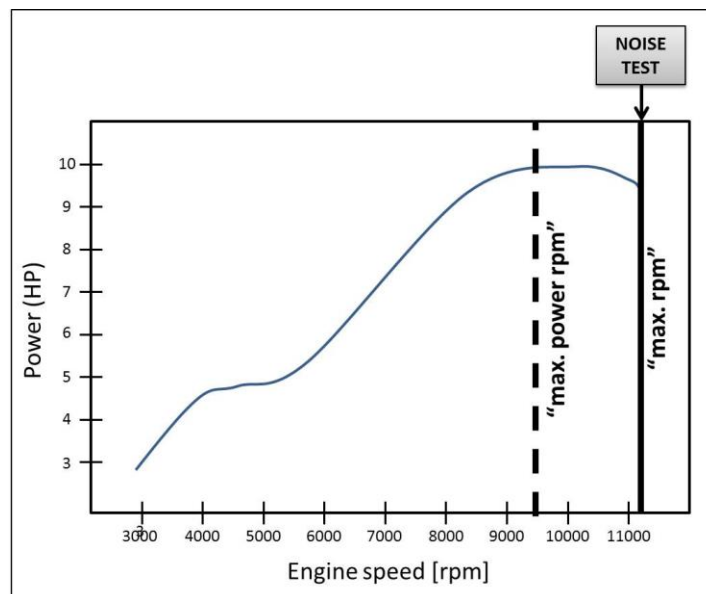

For Trial, the "max rpm" is established at 10000 (± 200) rpm and obtained thanks to a dedicated "sound test" mapping of the internal ECU or an external one, purpose-made and connected in occasion of the test.

For Track-Racing with FIM homologated silencers, when sound tests are needed, the "max rpm" is established at 11000 (± 500) rpm.

The SCO then keeps the engine at the "max. rpm" value for at least 1 s (or until there is an audible sign of over-revving the engine), during which the measurement is taken.

To conclude the test, the SCO releases the throttle quickly.

The maximum noise value (dB/A) registered during the measurement interval is then read on the sound meter and recorded. This noise value shall not be rounded down to the nearest whole number.

The noise value is then compared with the sound limits (see Art. 79.04).

The noise test can be "**PASSED**" or "**NOT PASSED**":

- "**PASSED**": The sound test is considered "passed" if the recorded noise value is below or equal to the sound limits of Art. 79.04. The silencer can then be marked by the SCO at the end of the test.

The silencer shall not be changed after verification, except for the spare silencer (see Art. 79.05) that has also been checked and marked.

The end opening of the silencer shall remain unmodified once it has been checked and marked.

- "**NOT PASSED**": The sound test is considered "not passed" if the recorded noise value is above the sound limits of Art. 79.04.
In this case, the vehicle (with the same silencer) can be presented again, but for two more tests maximum.
If the third test result is negative, the rider
 - can present a different or repaired silencer (in case the sound test was done before the race)
 - will receive a penalty (in case the sound test was done during or after the race).

The sound meter is then reset by pushing on the side-line and armed by pushing on the side-line again.

Notes:

- If the engine starts to misfire, close the throttle slightly and re-open the throttle.
- If detonations appear, the measurement must be started again.

- For vehicles without an engine rev. limiter, the throttle will have to be opened not more than 2 s or until there is an audible sign of over-revving the engine.
- Even in case a vehicle has not exceeded the respective sound limit, if there is any doubt, the vehicle may be checked again.
- If the vehicle is unable to reach the "max. power rpm" value, the vehicle shall be refused. Any attempt by a participant to prevent his engine from reaching the "max. power rpm" will be considered a breach of the rules.
- In case the SCO doubts that the "max. power rpm" value (as declared by the manufacturers or previously obtained with the dyno test), he/she shall measure the engine speed with a tachometer connected to the spark.

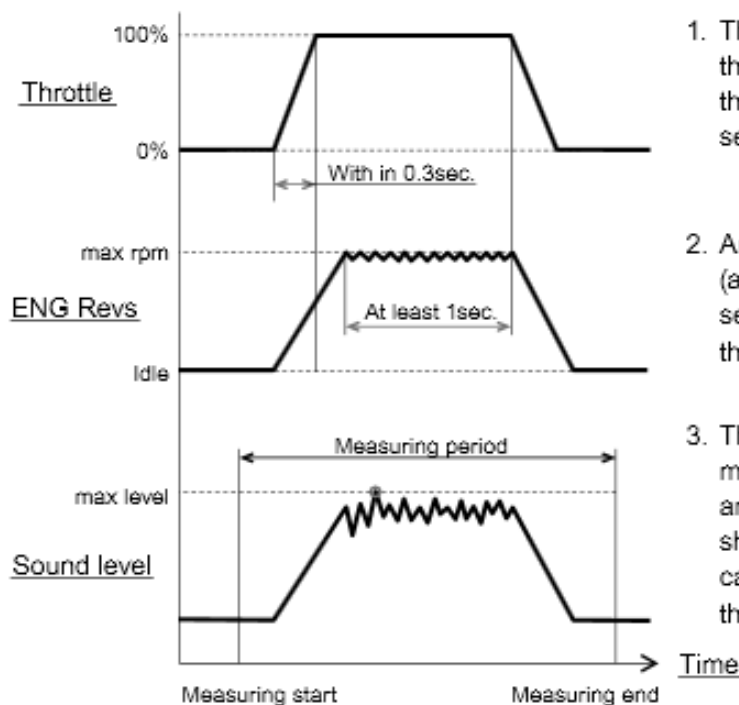

1. The Inspector shall open the throttle until full open throttle within 0.3 seconds.
2. And keep at the max rpm (at rpm limiter) at least 1 second. Then, release the throttle quickly.
3. The sound level is measured in the all period and the maximum level shall be recorded in any case. (automatically by the sound meter).

79.04 Sound limits

TRACK RACING World Championships, Cups and Prizes
Maximum Sound limit
Before or during race
115.0 dB/A

NOTES:

- The values already take into account the accuracy of the method.

- No deductions for ambient temperature, pressure or altitude are allowed.
- The measured noise value shall not be rounded down to the nearest whole number.

79.05 Spare silencers

The rider or the mechanic can present at the sound control, together with the vehicle, one (1) spare silencer to be checked.

Other spare silencers may be presented after all participants have presented their vehicles, or on the following days of the event.

79.06

Action and decisions will depend on the Sporting Discipline concerned, and decisions taken during prior discussions with the FIM Technical Director and/or the Chief Technical Steward.

79.07

In a competition which requires a final examination of machines before the results are announced, this examination must include a sound control measurement of at least three machines chosen at the discretion of the Clerk of the Course/FIM Race Director in co-operation with the Chief Technical Steward. Refer to each discipline for more info.



FÉDÉRATION INTERNATIONALE
DE MOTOCYCLISME

FIM-MOTO.com

11, ROUTE DE SUISSE | CH - 1295 MIES

cti@fim.ch

65 790 05