



FÉDÉRATION INTERNATIONALE
DE MOTOCYCLISME

**TECHNICAL RULES
ENDURO**

2021

*RÈGLEMENTS TECHNIQUES
ENDURO*

Technical Rules Enduro

2021

Règlements Techniques Enduro

Version 0
Applicable as from 01.03.2021

YEAR 2021		
Version	Applicable as from	Modified paragraphs
0	01.01.2021	01.07, 25.01, 01.29, 29.01, 35.05, 37.02, 01.39, 41.02, 01.46, 01.47, 49.01, 01.53, 55.03, 55.04, 55.05, 55.06, 55.07, 65.01, 01.70, 79.02

Table of contents

01.01	INTRODUCTION	4
01.03	FREEDOM OF CONSTRUCTION	4
01.05	CATEGORIES AND GROUPS OF MOTORCYCLES	4
01.07	CLASSES	5
01.11	MEASUREMENT OF CAPACITY	6
01.17	SUPERCHARGING	7
01.18	TELEMETRY	7
01.19	MOTORCYCLE WEIGHTS	8
01.21	DESIGNATION OF MAKE	8
01.23	DEFINITION OF A PROTOTYPE	8
01.25	GENERAL SPECIFICATIONS	8
01.26	DEFINITION OF A FRAME OF A SOLO MOTORCYCLE	9
01.27	STARTING DEVICES	9
01.29	OPEN TRANSMISSION GUARDS	9
01.31	EXHAUST PIPES	10
01.33	HANDLEBARS	11
01.35	CONTROL LEVERS	12
01.37	THROTTLE CONTROLS	12
01.39	FOOTRESTS	13
01.41	BRAKES	13
01.43	MUDGUARDS AND WHEEL PROTECTION	13
01.45	STREAMLINING	14
01.46	SUSPENSION	14
01.47	WHEELS AND RIMS, AND TYRES	14
01.49	TYRES	14
01.50	ADDITIONAL SPECIFICATIONS FOR	
	ELECTRIC POWERED VEHICLES	16
01.53	ADDITIONAL SPECIFICATIONS FOR SIDECARS	21
01.55	NUMBER PLATES	23
01.56	LIGHTING, WARNING EQUIPMENT AND SPEEDOMETERS	25
01.63	FUEL AND LUBRICANT	25
01.65	EQUIPMENT AND PROTECTIVE CLOTHING DURING PRACTICE AND RACE	33
01.67	WEARING OF HELMETS	34
01.69	HELMET OPERATIVE INSTRUCTIONS	34
01.70	RECOGNISED HELMET APPROVAL MARKS	35
01.73	NATIONAL COLOURS FOR HELMETS	36
01.75	BADGE OF THE FIM	38
01.76	NUMBER SASHES (BIBS)	38
01.77	TECHNICAL VERIFICATIONS	39
01.78	DANGEROUS MACHINES	45
01.79	SOUND CONTROL	45

DIAGRAMS

Any references to the male gender in this document are made solely for the purpose of simplicity, and refer also to the female gender except when the context requires otherwise.

01.01 INTRODUCTION

The term motorcycle covers all vehicles having, in principle, less than four wheels, propelled by an engine and designed essentially for the carriage of one or more persons of which one is the rider of the vehicle. The wheels must normally be in contact with the ground except momentarily or in certain exceptional circumstances. Furthermore, in order to traverse certain surfaces one or all of the wheels can be replaced with skis, rollers or chains.

01.03 FREEDOM OF CONSTRUCTION

A motorcycle must conform to the requirements of the FIM regulations, to the Supplementary Regulations, as well as to a number of specific conditions that the FIM may require for certain competitions. No restriction is placed on the make, construction or type of motorcycle used.

All solo motorcycles (Group A) must be constructed in such a way that they are entirely controlled by a rider. Motorcycles with Sidecars (Group B) must be constructed to carry a passenger.

01.05 CATEGORIES AND GROUPS OF MOTORCYCLES

Motorcycles are divided into categories which must be observed for all meetings and world record attempts.

In principle, it is forbidden for different categories, groups and classes to compete in the same race, unless the Supplementary Regulations state otherwise.

Category I

Motorcycles propelled by the action of one wheel in contact with the ground.

Category II

Special vehicles propelled by the action of one or two wheels in contact with the ground but which are not covered by the conditions of Category I.

Group A1 - Solo Motorcycles

2-wheel vehicles making only one track on the ground.

Group B1

Vehicles with three wheels, making two tracks on the ground, consisting of a motorcycle making one track and a sidecar for a passenger making the other track.

Group B2

Vehicles with three wheels, making two or three tracks on the ground in the direction of forward travel, with a permanently attached Sidecar forming a complete integral unit.

If three tracks are made, the centre-lines of the two tracks made by the motorcycle wheels must not be more than 75 mm apart. A track is determined by the longitudinal centre-line of each of the vehicle's wheels in the direction of forward travel.

Category III

Vehicles propelled by the action of multiple driving wheels in contact with the ground in only one direction.

Group C - Special 2 wheel driven motorcycles

Group D - Special 3 wheel, 2 wheel driven motorcycles

Group E - Snowmobiles

Group F - Sprinters and Dragsters

Group G - Quad racers

Group J – Electric Powered Vehicles (EPVs, see Art. 01.50)

01.07 CLASSES

Groups are again separated into classes according to cylinder capacities as detailed below. Generally, these classes must be observed for all meetings. However, see Arts. 061.41 and 062.21 of the Enduro rules for the International Six-Day Enduro (ISDE) and the Enduro World Championship.

Category I

Group A1 - Solo Motorcycles

Class (cc)	over (cc)	up to(cc)
50	-	50
65	50	65
85	65	85

100	85	100
125	100	125
150	125	150
175	150	175
250	175	250
350	250	350
450	250	450
500	250	500
750	500	750
1000	750	1000
1300	1000	1300

Note: For classes 50, 65, 85, 100, 125 and 150 only single cylinder engines are allowed.

Same as groups A1 and A2 over 175 cc.

Category II

Same classes as Category I, Group A1.

Category III

Same classes as Category I, Group A1.

01.11 MEASUREMENT OF CAPACITY

11.11 Reciprocating movement engine, "Otto" Cycle

The capacity of each engine cylinder is calculated by the geometric formula which gives the volume of a cylinder; the diameter is represented by the bore, and the height by the space swept by the piston from its highest to lowest point:

$$\text{Capacity} = \frac{D^2 \times 3.1416 \times C}{4}$$

where D = bore
and C = stroke

When a cylinder bore is not circular the cross sectional area must be determined by a suitable geometrical method or calculation, then multiplied by the stroke to determine capacity.

When measuring, a tolerance of 1/10 mm is permitted in the bore. If with this tolerance the capacity limit is exceeded for the class in question, a further measurement should be taken with the engine cold, to 1/100 mm limits.

11.13 Rotary engines

The capacity of an engine which determines the class in which the motorcycle shall compete in a meeting shall be calculated by:

$$\text{Capacity} = \frac{2 \times V}{N}$$

where V = total capacity of all the chambers comprising the engine
and N = number of turns of the motor necessary to complete one cycle in a chamber.

This engine is classified as a 4-stroke.

11.15 Wankel system

For Wankel system engines with a triangular piston, the capacity is given by the formula:

$$\text{Capacity} = 2 \times V \times D$$

where V = capacity of a single chamber
and D = number of rotors

This engine is classified as a 4-stroke.

01.17 SUPERCHARGING

Supercharging by means of a device of any kind is forbidden in all meetings.

An engine whether 2-stroke or 4-stroke coming within any one of the recognised classes (determined by the capacity of the working cylinder) shall not be considered as supercharged when in respect of one engine cycle, the total capacity measured geometrically, of the fuel charging device or devices, including the capacity of the working cylinder (if used for injecting the fuel), does not exceed the maximum capacity of the class in question.

01.18 TELEMETRY

Information must not be transmitted in any way to or from a moving motorcycle.

An official signalling device may be required on the machine.

Automatic lap timing devices are not considered as "telemetry".

Automatic lap timing devices must not disrupt any official time keeping methods and equipment.

01.19 MOTORCYCLE WEIGHTS

At present, there are no minimum weight limits for motorcycles. Minimum weight limits may be introduced in the future.

01.21 DESIGNATION OF MAKE

When two manufacturers are involved in the construction of a motorcycle the name of both must appear on the machine as follows:

- The name of the chassis manufacturer
- The name of the engine manufacturer

01.23 DEFINITION OF A PROTOTYPE

A prototype motorcycle is a vehicle which must conform to the safety requirements as required by the FIM Sporting Code and Appendices applicable to the type of competition for which it is to be used.

01.25 GENERAL SPECIFICATIONS

The following specifications apply to all vehicles of the groups indicated and to all types of competitions except where otherwise stated in the corresponding section of the FIM Sporting Code.

They should also be applied to all national competitions unless the FMNR (National Motorcycling Federation) has otherwise directed.

Further specifications for some competitions may also be required and these will be detailed in either the appropriate FIM Appendix or in the Supplementary Regulations for the competition in question.

Concerning material verification, in case of doubt, a sample or the part in question shall be taken and analysed at a Material Testing laboratory.

25.01 Use of titanium

The use of titanium **alloy** in the construction of the frame, the front forks, the handlebars, the swinging arms, the swinging arm spindles and the wheel spindles is forbidden.

The use of light alloys for wheel spindles is also forbidden.

The use of titanium alloy nuts and bolts is allowed.

25.03 Carbon fibre

The use of carbon fibre reinforced materials is authorised (with the exception of handlebars and wheel rims).

25.04 Ceramic materials

The use of ceramic parts is forbidden.

25.05 Other equipment

No signal of any kind may pass between a moving motorcycle and any person, including radio and Bluetooth communication. The exception is for the signal from the time keeping transponder, automatic lap timing devices or from the approved on-board cameras (with prior written approval from the Championship Promoter/Organiser, which cannot be granted for helmet mounted cameras).

25.06 Number of cylinders

The number of cylinders in an engine is determined by the number of combustion chambers.

25.07

If separate combustion spaces are used they must be connected by an unrestricted passage of minimum cross sectional area at least 50% of the total inlet port area.

01.26 DEFINITION OF A FRAME OF A SOLO MOTORCYCLE

The structure or structures used to join any steering mechanism at the front of the machine to the engine/gear box unit and to all components of the rear suspension.

26.01

Every motorcycle in the 'parc-fermé' must be equipped with a side-stand. The side-stand must be fitted, either on the frame or on the swing arm.

01.27 STARTING DEVICES

Starting devices for the engine are compulsory.

01.29 OPEN TRANSMISSION GUARDS

A guard must be fitted to the countershaft sprocket

29.01

If the primary transmission is exposed, it must be fitted with a guard as a safety measure. The guard must be designed so that rider or the passenger cannot under any circumstances come into accidental contact with the transmission parts. It must be designed to protect the rider or passenger from injuring his fingers.

29.04

A chain guard must be fitted in such a way to prevent trapping between the lower chain run and the final driven sprocket at the rear wheel.

01.31 EXHAUST PIPES

Exhaust pipes and silencers must fulfil all the requirements concerning sound control (see also Art. 01.79).

31.01

The axis of the silencer end must be parallel (tolerance 15°) to the two principal longitudinal planes of the vehicle. The extremity of the silencer must not pass the vertical tangent of the rear tyre.

31.02

The edge of the silencer shall not be dangerous in case of accidental contact with the riders or helpers. If the final tube protrudes more than 3 mm, the edge must be rolled to an angle of 180° or radiused (see pictures below). In both cases, the edge thickness shall be 3 mm minimum.

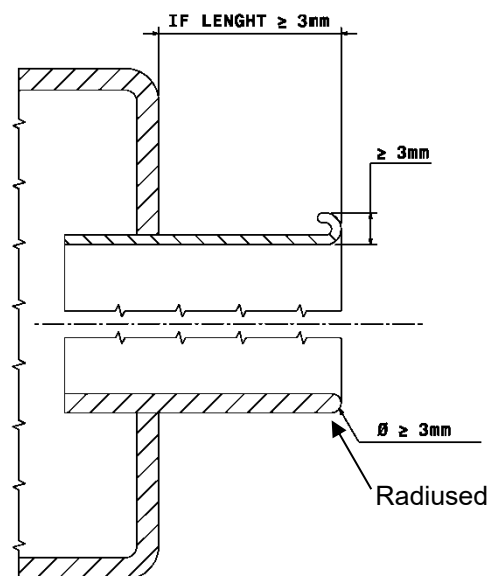

31.03

Exhaust fumes must be discharged towards the rear but not in such a manner as to raise dust, foul the tyres or brakes, or inconvenience the passenger (in the case of sidecars), or any other rider.

31.04

On a Sidecar machine the exhaust must discharge horizontally and towards the rear, at a maximum angle of 30° to the axis of the machine.

31.05

Any valve systems installed on the exhaust system with a view to influencing (or modifying) the sound level meter test is forbidden. Only exhaust valve systems (e.g. EXUP) provided by the manufacturer on the manifold are authorised. The setting is free.

01.33 HANDLEBARS

33.01

The width of handlebars must be not less than 600 mm and not more than 850 mm (see Diagram S).

33.02

The handlebars must be equipped with a protection pad on the cross bar. Handlebars without a cross member must be equipped with a protection pad located in the middle of the handlebars, covering widely the handlebars clamps.

33.03

Handlebar clamps must be very carefully radiused and engineered so as to avoid any fracture points in the handlebar.

33.04

Exposed handlebar ends must be plugged with a solid material or rubber covered.

33.06

When hand protectors are used, these must be made of a shatter-resistant material and have a permanent opening for the hand.

33.07

Handlebars made of composite materials are not authorised.

33.08

Repair by welding of light alloy handlebars is prohibited.

33.09

Solid stops (when on full-lock, other than steering dampers) must be fitted. These must ensure a minimum clearance of 30 mm between the handlebar with levers and the tank to prevent trapping the rider's fingers.

01.35 CONTROL LEVERS

35.01

All handlebar levers (clutch, brake, etc.) must be in principle ball ended (diameter of this ball to be at least 16 mm). This ball can also be flattened, but in any case the edges must be rounded (minimum thickness of this flattened part 14 mm). These ends must be permanently fixed and form an integral part of the lever.

If the gear lever consists of a tube, then its edge must be rounded.

35.03

Each control lever (hand and foot levers) must be mounted on an independent pivot.

35.04

The brake lever if pivoted on the footrest axis must work under all circumstances, such as the footrest being bent or deformed.

35.05

Hand -and foot- controls may be modified for mobility challenged riders.

01.37 THROTTLE CONTROLS

37.01

Throttle controls must be self-closing when not held by the hand. The throttle operation (opening and closing) shall only be activated by mechanical cable from the twist grip directly attached to the throttle valve. Electronically controlled throttle valves are forbidden. All air intakes into the cylinder must pass through the throttle body. No other means allowing ambient air into the inlet track of the cylinder head are allowed.

37.02

In the case of vehicles belonging to Group J (Electric vehicles), refer to Art. 50.04.6.

37.03

Solo motorcycles must be equipped with a functional ignition kill switch or button mounted on either right or left side of handlebar (within reach of the hand while on the hand grips), that cut the power to the engine.

01.39 FOOTRESTS

Footrests must be solidly fixed or of a folding type but in this case must be fitted with a device which automatically returns them to the normal position, and an integral protection is to be provided at the end of the footrest which must have at least 8 mm radius (see Diagrams). The footrest teeth shall not be sharp. The height of the footrest teeth must be 10 mm maximum.

01.41 BRAKES

41.01

All motorcycles must have at least 2 efficient brakes (one on each wheel) operated independently.

41.02

~~Vehicles in Group B must be fitted with at least 2 efficient brakes operating on at least 2 of the wheels and be operated independently.~~

01.43 MUDGUARDS AND WHEEL PROTECTION

Motorcycles must be fitted with rounded mudguards.

43.01

Mudguards must project laterally beyond the tyre on each side.

43.02

The front mudguard must cover at least 100° of the circumference of the wheel. The angle formed by one line drawn from the front edge of the mudguard to the centre of the wheel and one drawn horizontally through the centre of the wheel must be between 45° and 60°.

43.03

The rear mudguard must cover at least 120° of the circumference of the wheel. The angle formed by two lines, one drawn from the rear edge of the mudguard to the centre of the wheel and one drawn horizontally through the centre of the wheel shall not exceed 20°.

The angle (20° max.) for the rear mudguard shall be measured with the rider sitting on the motorcycle (See Diagram S).

01.45 STREAMLINING

No type of streamlining is allowed.

Radiator covers (shields) must be made of flexible materials only (e.g. plastics).

01.46 SUSPENSION

Electronically controlled suspension systems may not be used.

01.47 WHEELS AND RIMS, ~~AND TYRES~~

47.01

All tyres will be measured mounted on the rim at a pressure of 1 kg/sq.cm (14 lb./sq.in); measurements are taken at a tyre section plane with a 90° angle with the ground plane.

47.02

Any modification to the rim or spokes of an integral wheel (cast, moulded, riveted) as supplied by the manufacturer (other than for rims with spokes, or valve and security bolts) is prohibited, except for tyre retention screws sometimes used to prevent the tyre movement relative to the rim. If the rim is modified for these purposes, bolts, screws, etc., must be fitted.

01.49 TYRES

49.01 General

Only tyres normally available from commercial or retail sources are authorised.

Modifying the tyre is not authorised. It is forbidden to treat tyres with chemicals, cut or groove them, use tyre warmers or any other means which may alter the shape, minimum Shore hardness, construction or other characteristics.

The tyres shall appear on the tyre manufacturers range catalogue or tyre specification lists available to the general public.

Any marking on the tyre reporting "FIM" approved or similar is forbidden for new production dates (from 2018).

49.02 Enduro Tyres

They shall be approved according to UN Vehicle Regulation 75 Rev. 2 (2010) with the following specific features:

- Category of use (5.2): it shall be "snow" or "special" or "All terrain"
- Speed category symbol (5.4): M (130 Km/h) or above
- Load capacity index (5.5): 45 (165 Kg) or above.

It is recommended that the tyres be used according to the European Tyre and Rim Technical Organisation (ETRTO) guidelines.

The E approval mark and number as defined by the UN Vehicle Regulation R75 must be present on both the front and rear tyre sidewalls.

The DOT approval mark is also accepted.

The rear tyre must present a tread groove with a maximal depth of 13 mm. Such a depth must be measured between the "minimum" of the tread groove and a line tangent with the side wall (see Diagram S).

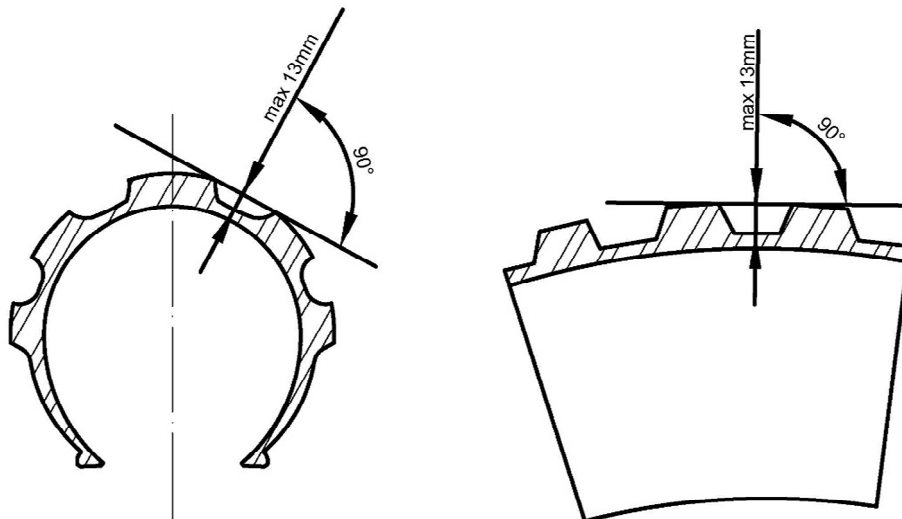

49.03 Motocross Tyres

Motocross tyres (Art. 01.49 of Technical rules for Motocross) are strictly forbidden.

49.04 Trial Tyres

Trial tyres (Art. 20 of Technical rules for Trial) are strictly forbidden.

49.05 Tyres with studs

The use of studded tyres will be defined in the Supplementary Rules of the event.

The use of studded tyres shall be approved by the Clerk of the Course/FIM Race Director, based on the state of the course.

Only studded tyres available from commercial tyre retail sources are authorised. These shall appear on the manufacturer's tyre catalogue or tyre specification list available to the general public.

All dimensions of the studs, their number, method of mounting, etc., must be in accordance with the national legislation of the country where the event is held.

Scoop or paddle tyres (continuous radial rib) are forbidden

01.50 ADDITIONAL SPECIFICATIONS FOR ELECTRIC POWERED VEHICLES

50.01 INTRODUCTION

The technical concept is reserved for motorcycles propelled by non-thermal energies with zero toxic/noxious emissions and by the action of one wheel in contact with the ground.

Amendments to these technical regulations may be made at any time in order to ensure fair competitions.

50.02 GENERAL EPV CLASS REQUIREMENTS

EPVs refer to two- and/or three-wheeled autonomous electric powered motorcycles, having traction on one or both wheels (with an unpowered sidecar if applicable).

The number of electric motors is limited to one.

50.02.1 Race Procedures

(Race procedures to be defined by the Sporting Commission concerned).

50.02.2 Race Format (Guidelines – actual race format depends on the discipline and battery life)

Minimum race length: 20 minutes

Maximum race length: 30 minutes

50.02.3 Charging the accumulator

Energy supply will be provided in the paddock at the times and locations determined by the race Organiser.

Charging may only be done with the energy supply provided by the race Organiser.

The charging system must be separate from the machine and comply with all electrical safety requirements including thermal overload trip, fusing and be equipped with an earth leakage protection breaker.

50.02.4 Pit Stop

Riders will be allowed to define their own method of energy renewal subject to safety and practical considerations subject to the approval of the race Organiser.

Riders who wish to have a pit stop must declare the process and technology to the FIM Technical Director/Chief Technical Steward for a safety evaluation. All information will be treated with strict confidentiality.

50.02.5 Transponder timing

All machines must be equipped with an official transponder.

50.02.6 Technical Verifications

As a condition of entry, all safety items on-board the motorcycle must be precisely described and presented at the Technical Verifications.

The Technical Steward shall check both the machine and the rider for compliance with the technical specifications, as well as the employment of good engineering construction practice, and the presence of adequate electrical insulation and weatherproofing.

Damaged machines must be returned to the Technical Verifications area for examination after race or practice. In such circumstances it is the responsibility of the competitor to ensure both his machine and clothing have been rechecked and approved before further use in the event. If stickers/marks are used, a new sticker/mark must be in place.

It is the responsibility of the rider to ensure that a machine used in competition is electric, mechanically and structurally in a safe condition.

In case of a dispute, the decision of the FIM Technical Director will be final.

50.02.7 Conformity

It is the duty of each competitor to show the Technical Stewards of the meeting that his vehicle fully complies with these rules and the rules governing the meeting, in their entirety at all times.

50.03 General vehicle specifications

50.03.1 Requirements

All motorcycles must comply in every respect with all the requirements for racing as specified in the FIM General Technical Specifications, unless otherwise specified below.

The power circuit consists of all those parts of the electrical equipment which are used to propel the motorcycle. The on-board circuit consists of all those parts of the electrical equipment which are used for signalling, lighting or communication.

The accumulator is defined as any on-board equipment used for the storage of electrical energy supplied by the charging unit.

Recovering energy generated by the kinetic energy of the vehicle is permitted.

The use of any external source of energy in any form whatsoever with the aim of improving the performance of the vehicle is strictly prohibited.

50.03.2 Number Plates and Colours

See Art. 01.55.

50.03.3 Handlebars

See Art. 01.33.

50.03.4 Control levers

See Art. 01.35.

50.03.5 Foot Rest/Foot Controls

See Art. 01.39.

50.03.6 Wheel and rims

See Art. 01.47.

50.03.7 Tyres

See Art. 0.49.

50.03.8 Streamlining

See Art. 01.45.

50.03.9 Machine Weight

Neither a minimum nor a maximum weight are applied.

50.03.10 Overall Dimensions

The specific dimensions for the vehicles of this discipline apply.

50.03.11 Inclination

It must be possible for a motorcycle not being loaded, to be inclined to an angle of 40 degrees from the vertical, without any part of it other than the tyre coming in contact with the ground.

In race conditions, the vehicle must be capable of affecting a standing start on an uphill slope with a gradient of 18%.

50.04 Electrical safety

It must be ensured that the components used cannot cause injury under any circumstances, either during normal operation or in foreseeable cases of malfunction. It must be ensured that the components used for protecting persons or objects can reliably fulfil their function for an appropriate length of time.

50.04.1 Electrical components

All parts of the electrical equipment must be protected to at least the equivalent of IP 44 type protection (dust proof and splash proof). Exposed connectors/wires must be protected against abrasion in case of accident (side covers).

50.04.2 Power bus maximum voltage

The maximum allowed voltage in the main power bus is 400VDC or 285VAC. A secondary power bus may be used to supply energy to the critical systems at a maximum voltage of 20VDC or 14VAC.

50.04.3 High voltage symbols

Symbols warning of 'HIGH VOLTAGE' must be displayed on or near the electrical equipment protective covers; all symbols must comprise a black flash of lightning inside a yellow triangle with a black border. The sides of the triangle must measure at least 8 cm, but may be larger if practical.

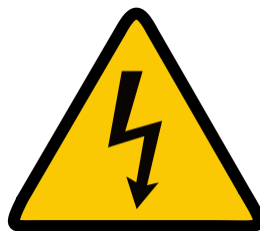

50.04.4 Insulation

Every part of the electrical equipment must be electrically insulated relative to all live components and system ground. Maximum default current is 20mA.

Wiring insulators can be required to be checked at any time by the FIM Technical Director/Chief Technical Steward. Double insulation will be required in high voltage or high current wires. Technical datasheets of the wires used will prevail under all circumstances.

Plus and minus wires from the battery must be insulated with respect to the chassis to withstand battery maximum voltage at least.

All electrically conducting non-live parts must be connected with the system ground.

In cases where the voltage of the power circuit exceeds 36VDC, the power circuit must be separated from the on-board circuit by an appropriate insulator.

Insulating material not having sufficient mechanical resistance, i.e. paint coating, enamel, oxides, fibre coatings (soaked or not) or insulating tapes are not accepted.

50.04.5 Power Indicator

When the vehicle is in a ready state, there must be two clearly visible indicators, one light on the instrument panel/on the front close the center of the handlebar and one light on the rear of the vehicle.

The rear light must be red and visible from at least 10 m away, from the rear or the side.

50.04.6 General circuit breaker – 'Emergency Stop'

The general circuit breaker must disconnect from the cut-off switch and discharge the main bus voltage below 60V. This system will be referred to as general circuit breaker or "Emergency stop".

Low power accumulators provided for low voltage circuits, e.g. auxiliary circuits, do not have to be isolated by the general circuit breaker (Emergency Stop) provided that they are completely isolated from the main power accumulators.

50.04.7 Fuses (over-current trip switches)

An over-current trip switch is a device which automatically interrupts the electrical current in which it is installed if the level of this current exceeds a defined limit value for a specific period of time.

Fuses must under no circumstance replace the general circuit breaker (Emergency Stop).

50.04.8 Capacitors

Voltage across capacitors belonging to the power circuit should fall below 65 volts within 5 seconds after the general circuit breaker is opened or the over current trips of the accumulator are blown.

50.04.9 Power control

A 'self-closing' throttle (power control) must be applied.

50.04.10 Accumulator (storage battery)

The type, dimensions and weight of accumulator/s cannot be changed between official practices and race.

All on-board electrical equipment, unless consisting of items originally powered by dry batteries, small accumulators or their own solar cells, must receive its energy supply from the vehicle's official accumulators.

IMPORTANT: As a condition of entry, a Material Data Safety Sheet must be supplied with the race entry for the machine, including all relevant details as to the accumulator chemistry, human and environmental hazards, handling and specific fire risks and precautions.

50.04.11 Accumulator fastening

The accumulator must be installed securely inside the vehicle and be protected against short-circuits and leakage. The accumulator must be attached to the frame or chassis using metal clamps with an insulating covering.

The fixing method must be designed in such a way that neither the accumulator nor the fastening device itself nor its anchorage points can come loose, even when subjected to a crash. A solid partitioning bulkhead must separate the location of the accumulator from the rider.

Each accumulator box must provide its own cooling and/or venting system. In modular battery systems, a heat shield is strongly recommended between modules, by means of an adiabatic shield or intumescent.

The accumulator installation must ensure that in the event of accumulator cell leakage or explosion, the contents are kept away from the rider and do not interfere in any way with the rider's vision or the safe handling of the machine.

~~01.53~~ ADDITIONAL SPECIFICATIONS FOR SIDECARS

~~53.01~~

~~The Sidecar must be fixed to the motorcycle in at least three points, if it is not an integral part of the chassis.~~

~~The fixing points must not allow movement at the joints (articulated Sidecars are strictly forbidden). If the angle of the inclination is changeable, it must be locked in such a way that the fixing method is completely secured and not only clamped on.~~

~~A structure of crossed belts or a metallic grid must be fitted to fill the opening between the wheels and the sidecar, to prevent the rider's foot from accidentally touching the ground.~~

~~The fuel tank must be sufficiently and independently protected from the ground.~~

53.06

~~The drive shall be transmitted to the ground only through the rear wheel of the motorcycle.~~

53.07

~~The distance between the tracks left by the centre lines of the rear motorcycle wheel and the Sidecar wheel must be at least: 800 mm and not more than 1150 mm.~~

53.09

~~To reduce the torque in the steering, a maximum displacement of 75 mm is permitted between the front and the rear wheel.~~

53.10

~~The steering of the front wheel must be accomplished without any intermediate articulated steering joints directly by a classic telescopic fork or a swinging arm fork with the wheel supported equally each side (long or short leading link type). All other types of front wheel steering and suspension are forbidden.~~

53.11

~~The minimum dimensions of a Sidecar available for passenger accommodation are:~~

~~—— Length: 1 000 mm — Width: 400 mm~~

~~Height of the screen protecting the passenger: 300 mm minimum (see Diagram N).~~

53.12

~~The minimum ground clearance of a laden Sidecar when measured must not be less than 175 mm.~~

53.13

~~The position of the engine is optional, except that it must be positioned in front of the rear wheel.~~

~~The centre line of the engine corresponds to the crankshaft axis (for longitudinal engines) and to the centre line of the cylinders block (for transverse engines). The centre line of the engine shall not exceed more than 160 mm beyond the centre line of the rear wheel of the motorcycle.~~

~~If the engine and gearbox are mounted on plates, the minimum thickness of the steel plates must be 4 mm, and 5 mm for light alloy plates.~~

53.14

~~Handlebars must be firmly secured to the forks. They must be at a height above the mid-point in the seat.~~

~~The motorcycle must have a steering head which must be fitted like the handlebar, and must not be attached to the unsuspended part of the front wheel suspension.~~

53.15

~~The seat must have minimum dimensions of 300 mm x 150 mm and must be fixed at a minimum height of 300 mm above the Sidecar floor (see Diagram N).~~

53.16

~~For Sidecars, the Sidecar wheel must be covered or protected with a solid material.~~

53.17

~~Referring to the longitudinal axis of the motorcycle, the exhaust pipe shall not protrude beyond the width of the sidecar (if on the sidecar side) or protrude by more than 330 mm (if on the motorcycle side).~~

~~If the exhaust pipe is on the sidecar side, it must not exceed the vertical line drawn at a tangent to the rear edge of the Sidecar platform.~~

01.55 NUMBER PLATES

Number plates are required for Enduro. They must be fitted as follows.

55.03

Number plates must be made of flexible materials only (e.g. plastic). The shape of the front number plate is free and may be part of the general design of the motorcycle.

~~They must be rectangular in shape and made from a rigid and solid material with minimum measurements 285 mm x 235 mm. (See Diagram O).~~

55.04

The plates curved not more than 50 mm out of a true plane must not be covered or bent.

The following minimum dimensions must be respected:

- | | |
|-----------------------------|---------------|
| • Height of the number | 100 mm |
| • Width of each number | 50 mm |
| • Width of the stroke | 20 mm |
| • Space between two numbers | 10 mm |

The English form for numbers must be used. That is single vertical line for the "one" and a simple sloping line without a horizontal line for the "seven" (see Diagram O).

Reflecting numbers are forbidden.

The numbers must be clearly legible and like the background, they must be painted in matt colours to avoid reflection from sunlight. In case of a dispute, the decision of the FIM Technical Director will be final.

55.05 Front number plates

One plate must be fixed to the front inclined not more than 30° rearwards from the vertical. **Holes can not be perforated between the numbers on the number plate. Under no circumstances may the numbers be perforated.**

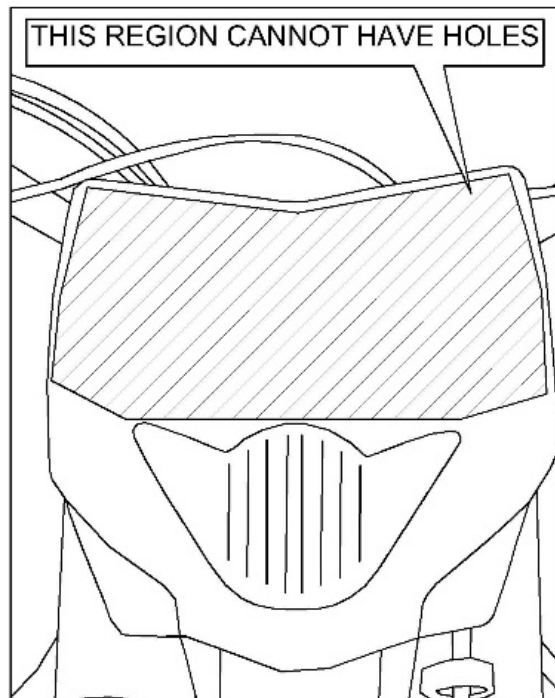

55.06 Side number plates

The side number plates must be positioned above a horizontal line drawn through the rear wheel spindle and the front edge of the plate must be behind a vertical line drawn at 200 mm to the rear of the rider's footrest.

They must be fixed in such a manner as to be clearly visible and they must not be masked by any part of the motorcycle or by the rider when seated in the riding position.

55.07

In place of separate plates, a space of equivalent size in matt colours can be painted or fixed on the bodywork.

55.09

All other number plates or markings on a motorcycle liable to cause confusion with the number must be removed before the start of a competition.

55.13

The figures must be applied to each machine by the organisers during the preliminary examination. The carrying of number plates is obligatory for the Six Days Enduro and any rider who retires during the event, must immediately remove them.

In case of a dispute concerning the legibility of numbers, the decision of the Technical Steward will be final.

01.56 LIGHTING, WARNING EQUIPMENT AND SPEEDOMETERS

Motorcycles and their equipment must comply with the national legal requirements for road traffic of the country in which the vehicle is registered and with other rules specified in the Supplementary Regulations.

The electric generator must operate continuously and normally with respect to current and voltage requirements to run front and rear lights during the competition and at post competition control. The electrical connections must be retained.

A stop light activated by the front or rear brake, a front and rear light as well as a speedometer, in good working order, are compulsory.

The registration number of the machine (if applicable) shall be displayed on a plate firmly fixed to the rear mudguard of the machine (not handwritten on the mudguard direct). The number plate or its copy must be made of flexible and non-cutting material and must not exceed the width of the rear mudguard.

With the engine running all electrical equipment/consumers of electricity simultaneously must be supplied with electricity produced by the generator.

In the absence of the stand, the access to the Parc Fermé will not be authorised.

Each motorcycle must be equipped with an exhaust pipe and a silencer in accordance with Article 01.31.

01.63 FUEL AND LUBRICANT

All vehicles must be fuelled with

- unleaded Fuel (from public pump station or race type) OR
- a mixture of unleaded Fuels OR
- a mixture of unleaded Fuel(s) and lubricant in the case of 2-stroke engines.

The unleaded Fuel or the mixture of unleaded Fuels used must comply with the FIM specifications as set out in Art. 63.01.

The mixture of unleaded Fuel(s) and lubricant must comply with the FIM specifications as set out in Art. 63.02.

Riders/teams must declare to the FIM Technical Director (or the FMNR Chief Technical Steward when there is no FIM Technical Director appointed) the make and type of Fuel to be used during practices and race(s), upon presentation of the rider/team's motorcycle(s) at the initial Technical Verifications. They are also recommended to provide a certificate issued by the Fuel company which certify that the Fuel has been tested and is in conformity with FIM specifications.

Fuel companies which supply 'race' Fuels (Fuels other than those obtained at public pump stations) to participating teams/riders must test their Fuel at Intertek Schlieren (Switzerland) against all the FIM specifications set out in Art. 63.01.

Providing the Fuel is within the FIM specifications, a certificate containing a test report and batch number will be issued to the fuel company.

The Fuel company shall be able to provide a copy of such certificate to their client rider/teams before they take part in a race.

Contact for fuel analysis: fimfuels@intertek.com.

A list of Fuels which are in conformity with FIM specifications will be published by FIM on the FIM website.

Furthermore, in the cases in which only Fuel from the appointed supplier is permitted (for a specific event or the entire World Championship, Prize or Cup), the aforementioned Fuel shall have been previously tested in a FIM appointed laboratory in order to test its conformity with the FIM specifications as set out in Art. 63.01:

- in case of conformity, a certificate of conformity (including test report and tested batch number) shall be available and Art. 01.63 applies in case of controls for the riders/teams;
- in case the conformity is not achieved, the FMN of the organising country/the Organiser/the Promoter shall ask the FIM for a waiver in order to enable the use of Fuel not corresponding to FIM specifications. If the waiver is granted, the riders/teams will be responsible for using the Fuel provided without changing its composition. Controls may be carried out by FIM.

63.01 FIM specifications for unleaded Fuels or mixtures of unleaded Fuels

The following specifications are set for unleaded Fuel or the mixture of unleaded Fuels:

- a) The following properties shall be within the following thresholds (for each property, the relative test methods to be used for the measurement are indicated):

Property	Units	Min.*	Max.*	Test Method
RON		95.0	102.0	EN ISO 5164 or ASTM D2699
MON		85.0	90.0	EN ISO 5163 or ASTM D2700
Oxygen (includes 10% ethanol allowance)	% (m/m)		3.7	EN ISO 22854 ¹ or EN 13132 or elemental analysis
Nitrogen	% (m/m)		0.2	ASTM D 4629 ² or ASTM 5762
Benzene	% (V/V)		1.0	EN ISO 22854 or ASTM D6839 or ASTM D5580
Vapour pressure (DVPE)	kPa		100.0	EN 13016-1 or ASTM D5191
Lead	mg/L		5.0	ICP-OES or AAS
Manganese	mg/L		2.0	ICP-OES or AAS
Density at 15°C	kg/m ³	720.0	785.0	EN ISO 12185 or ASTM D4052
Oxidation stability	minutes	360		EN ISO 7536 or ASTM D525
Sulphur	mg/kg		10.0	EN ISO 20846 or ASTM D5453
<u>Distillation:</u>				EN ISO 3405 or ASTM D86
E at 70°C	% (V/V)	20.0	52.0	
E at 100°C	% (V/V)	46.0	72.0	
E at 150°C	% (V/V)	75.0		
Final Boiling Point	°C		210	
Residue	% (V/V)		2.0	
Appearance	clear, bright and visually free from solid matter and undissolved water			Visual inspection
Olefins	% (V/V)		18.0	EN ISO 22854 or ASTM D6839
Aromatics	% (V/V)		35.0	EN ISO 22854 or ASTM D6839
Total diolefins	% (m/m)		1.0	GC-MS or HPLC
<u>Oxygenates:</u>				EN ISO 22854 ¹ or EN 13132
Methanol	% (V/V)		3.0	The only oxygenates permitted are paraffinic mono-alcohols and paraffinic mono-ethers (of 5 or more carbon atoms per molecule) with a final boiling point below 210°C.
Ethanol	% (V/V)		10.0	
Isopropanol	% (V/V)		12.0	
Isobutanol	% (V/V)		15.0	
<i>tert</i> -Butanol	% (V/V)		15.0	
Ethers (C5 or higher)	% (V/V)		22.0	
Others	% (V/V)		15.0	

¹ In cases of dispute EN ISO 22854 will be the reference method.

² In cases of dispute ASTM D 4629 will be the reference method.

*All reported min. and max. thresholds do not include the tolerance, which needs to be calculated in accordance with ISO 4259 and taken into account to correct the min. and max. thresholds.

- b) The total of individual hydrocarbon components present at concentrations of less than 5% (m/m) must constitute at least 30% (m/m) of the fuel. The test method will be GC-FID (gas chromatography-flame ionisation detector) and/or GC-MS (gas chromatography-mass spectrometry).
- c) The total concentration of naphthenes, olefins and aromatics classified by carbon number must not exceed the values given in the following table:

% (m/m)	C4	C5	C6	C7	C8	C9+
Naphthenes	0	5	10	10	10	10
Olefins	5	20	20	15	10	10
Aromatics	-	-	1.2	35	35	30

Bicyclic and polycyclic olefins are not permitted. The fuel must contain no substances which are capable of exothermic reaction in absence of external oxygen.

63.02 FIM specifications for mixtures of unleaded Fuel(s) and lubricant

The lubricant

- must not change the composition of the Fuel fraction when added to the Fuel;
- must not contain any nitro-compounds, peroxides or any other engine power boosting additives;
- must in no way contribute to an improvement in overall performance;
- during the distillation up to 250°C, must not show a reduction in mass by evaporation of more than 10% (m/m) (test method: simulated distillation GC);
- must contain a max. content of anti-knock agents (lead, manganese, iron) of 10 mg/Kg (test method: ICP-OES).

Moreover, the following specifications are set for the mixture of unleaded Fuel(s) and lubricant:

- a) The following properties shall be within the following thresholds (for each property, the relative test methods to be used for the measurement are indicated):

Property	Unit	Min.	Max.	Test Method
RON			102.0*	EN ISO 5164 or ASTM D2699
MON			90.0*	EN ISO 5163 or ASTM D2700
Density at 15°C	kg/m ³	690**	815**	EN ISO 12185 or ASTM D4052

*Reported min. and max. thresholds do not include the tolerance, which needs to be calculated in accordance with ISO 4259 and taken into account to correct the min. and max. thresholds.

** Min. and max. thresholds do include the tolerance.

63.03 Air

Only ambient air may be mixed with the fuel as an oxidant.

63.05 Sampling and Testing

The FIM may require Fuel controls, i.e. controls of the unleaded Fuel, mixture of unleaded Fuels or mixture of unleaded Fuel and lubricant, used by riders/teams at events. These controls involve an initial sampling at the event and further testing in the FIM appointed laboratory.

63.05.01 Sampling

- 1) The FIM Technical Director (or the FMNR Chief Technical Steward when there is no FIM Technical Director appointed) is the sole official responsible for the sampling management and supervision.
- 2) Riders/teams selected for Fuel controls are directed to proceed with their vehicles to the area that has been designated for this purpose.
- 3) The FIM Technical Director/FMNR Chief Technical Steward collects the Fuel from the motorcycle by using only new sample containers and pipettes/hand pumps.
The Fuel is transferred through the use of the pipette/hand pump directly from the Fuel tank into three containers, denominated A, B and C. The containers are closed and sealed by the FIM Technical Director/FMNR Chief Technical Steward.
- 4) The FIM Technical Director/FMNR Chief Technical Steward fills in (in all its parts) and signs the Fuel Sample Declaration Form (see 63.04.03). The rider or a team representative also signs this Form, after verifying that all the information is correct.
- 5) The FIM Technical Director/FMNR Chief Technical Steward prepares an appropriate shipping box containing the collected A, B and C samples and a copy of the respective, signed, Fuel Sample Declaration Form. The box is then shipped to the FIM appointed laboratory by registered courier.

63.05.02 Testing

- 1) One or more properties to be checked (following the relevant testing method as per Art. 63.01 and 63.02) are set by the FIM for each selected rider/team.
- 2) Sample A is the first sample to be tested by the FIM appointed laboratory.

- 3) Sample B can be used for a second analysis if required by the FIM. The test result of the A or B sample more favourable to the rider/team is taken into account. Costs for the shipping and testing of sample A and B are paid by FIM.
- 4) As soon as possible after completing the testing, the FIM appointed laboratory reports the test results directly to the responsible CTI Coordinator.
- 5) For negative cases (i.e. conformity of the tested property(ies) with the specification), the riders/teams concerned will be individually informed by the FIM in due course, copying the rider/team's FMN, the FIM Technical Director/FMNR Chief Technical Steward, the competent authority (e.g. Race Direction, International Jury), the CTI Director, the Director and Coordinator(s) of the sporting Commission concerned.
- 6) Only for positive cases following testing of sample A or B or A and B (i.e. non-conformity of one or more properties*), the responsible CTI Coordinator notifies by electronic mail* the rider/team concerned (including the testing results) and, 24 hours after, forwards the relevant information to the rider/team's FMN, the FIM Technical Director/FMNR Chief Technical Steward, the competent authority (e.g. Race Direction, International Jury), the CTI Director, the Director and Coordinator(s) of the sporting Commission concerned.
 *Note: The non-conformity of one property (except the Appearance) is sufficient for declaring non-conformity of the Fuel or the mixture.
- 7) If the rider/team wishes to request a counter-expertise, he must notify the responsible CTI Coordinator by electronic mail* accordingly, within 72 hours of receipt by the FIM of the delivery status notification pertaining to the notification of the test results to the rider/team.
 - If a counter-expertise is requested, the sample dedicated to the counter-expertise is sample C and the test shall aim at checking the same property(ies) previously checked on sample A/B. The rider/team can request that sample C be tested at one of the available FIM appointed laboratories. Costs for shipping and testing of sample C are paid by the rider/team concerned.
 Upon notification of the sample C results, the responsible CTI Coordinator notifies by electronic mail* the rider/team concerned (including the testing results) and forwards the relevant information to the rider/team's FMN, the FIM Technical Director/FMNR Chief Technical Steward, the competent authority (e.g. Race Direction, International Jury), the CTI Director, the Director and Coordinator(s) of the sporting Commission concerned.
 - If no counter-expertise is requested within the time limit, the responsible CTI Coordinator forwards the relevant information by electronic mail* the rider/team's FMN, the FIM Technical Director/FMNR Chief Technical Steward), the competent authority (e.g. Race Direction, International Jury), the CTI Director, Director and Coordinator(s) of the sporting Commission concerned.

- 8) The competent authority of the event concerned (e.g. Race Direction, International Jury) takes a decision based on the information received. The Coordinator of the sporting Commission concerned notifies the rider/team concerned regarding the decision by electronic mail*.

The non-conformity of

- A sample (in the cases B sample was not used) or
- B sample (in the cases A sample result was not conclusive) or
- A and B samples or
- A and B and C samples (in the cases B sample was used and a counter-expertise was requested) or
- A and C samples (in the cases B sample was not used and a counter-expertise was requested)

automatically results in the disqualification of the rider/team from the entire event.

No disqualification will be applied in case of conformity of sample C.

Furthermore, in any case, other penalties may be applied.

- 9) The rider/team has the right to appeal against the decision of competent authority of the event concerned (e.g. Race Direction, International Jury) in accordance with FIM Disciplinary and Arbitration Code applicable to the relevant discipline.

*The receipt of a delivery status notification will be deemed as proof of delivery.

63.05.03 Fuel Sample Declaration Form

 FIM WORLD CHAMPIONSHIPS, CUPS AND PRIZE EVENTS Fuel Sample Declaration Form									
Discipline									
IMN (xxx/xx)									
Rider/team's name									
Rider/team's number									
Rider/team's email or telephone number									
Team									
Vehicle's make									
Fuel's make and type									
Fuel origin (public station or race supplier)									
Fuel samples taken on date (dd/mm/yy)									
Fuel samples taken at (right before or right after): MOTOCROSS TRIAL TRACK RACING ENDURO/ISDE RALLIES/BAJAS <input type="checkbox"/> Practice <input type="checkbox"/> Day 1 <input type="checkbox"/> Heat n°__ <input type="checkbox"/> Day 1 <input type="checkbox"/> Day 1 <input type="checkbox"/> Qualifying race <input type="checkbox"/> Day 2 <input type="checkbox"/> Day 2 <input type="checkbox"/> Day 2 <input type="checkbox"/> Race 1 <input type="checkbox"/> Day n°__ <input type="checkbox"/> Day n°__ <input type="checkbox"/> Race 2									
	<table border="1"> <thead> <tr> <th></th> <th>Container seal n°</th> </tr> </thead> <tbody> <tr> <td>Sample A</td> <td></td> </tr> <tr> <td>Sample B</td> <td></td> </tr> <tr> <td>Sample C</td> <td></td> </tr> </tbody> </table>		Container seal n°	Sample A		Sample B		Sample C	
	Container seal n°								
Sample A									
Sample B									
Sample C									
<p>The above listed details refer to Fuel samples taken from the Fuel tank of the motorcycle specified. Sample A is the first testing sample to be used by the FIM appointed laboratory. Sample B can be used for a second analysis if required by the FIM. Sample C is used if a counter-expertise is required by the rider/team.</p> <p>The serial numbers of the vial seals and the accuracy of the listed information have been verified.</p>									
Rider or team responsible name									
Rider or team responsible signature									
FIM Technical Director/FMNR Chief Technical Steward name									
FIM Technical Director/FMNR Chief Technical Steward signature									

01.65 EQUIPMENT AND PROTECTIVE CLOTHING DURING PRACTICE AND RACE

The FIM cannot be held liable for any injuries that a rider or passenger may sustain from the use of a specific item of equipment or protective clothing.

65.01 Clothing and protectors

It is recommended to use suit, trousers, long-sleeve shirts and undergarments made of textiles which are not fully constituted of nylon or spandex (e.g. Lycra, Elastan), in order to avoid degradation in case of abrasion (friction).

It is compulsory that riders wear either suit or trousers and long-sleeve shirt, chest and back protectors.

It is compulsory that all protective devices are clearly marked with the relative norms and comply with the following standard:

- EN 1621-1, Level 1 or 2, for shoulders, elbows, hips and knees
- EN 1621-2, Level 1 or 2 for the back: CB (Central Back) and FB (Full Back)
- EN 1621-3, Level 1 or 2, for the chest or EN 14021*

***The chest protectors according to EN 14021 are allowed until 31.12.2021.**

It is strongly recommended to wear shoulder, elbow and knee protectors as well.

Repaired overalls are acceptable provided that the repair guarantees protection to the same standard as the original garment.

The Chief Technical Steward has the right to refuse any temporary repairs which are not deemed to provide the same protection as the original garment.

65.02 Footwear

Footwear, in a good condition, made of leather or other materials having equivalent properties, shall be worn and have a minimum height of 30 cm.

65.03 Gloves

Riders shall wear gloves made of leather or other materials having equivalent properties.

65.04 Eye protection

Riders shall wear goggles.

The use of glasses, helmet visors and "roll offs" is also permitted. The use of "tear offs" is forbidden for environmental reasons. The material used for glasses, goggles and visors must be made of shatter-proof material. Helmet visors must not be an integral part of the helmet.

Eye protectors which cause visual disturbance (e.g. scratched) must not be used.

01.67 WEARING OF HELMETS

- It is compulsory for all participants taking part in practice and races to wear a protective helmet. The helmet must be properly fastened, be of a good fit, and be in good condition. The helmet must have a chin strap type 'retention system'.
- A protective lower face cover must be present and must be not detachable, not moveable.
- Helmets constructed with an outer shell made of more than one piece are not permitted (e.g. they must not contain any seam).
- A retention system with a strap and the double D ring closing system is recommended.
- All helmets must be marked with one of the official international standard marks mentioned in Art. 01.70. Any FMN approval marks do not substitute the official international standard marks.
- A helmet is made to provide protection. A helmet is not a platform to attach foreign objects. Cameras or other accessories are NOT permitted nor shall be attached to the rider's helmet.
- Long hair, whether of female or male riders, must not come out of the helmet. Long hair must be completely contained within the helmet.

Failure to observe the above rules will entail exclusion.

01.69 HELMET OPERATIVE INSTRUCTIONS

69.01

Scrutineers, under the supervision of the Chief Technical Steward, may check prior to practice and the races that all helmets meet the technical requirements.

69.02

If a helmet does not meet the technical requirements or is found to be defective, the Technical Steward must clearly mark in red (e.g. with a red dot) all international marks without destroying them and retain the helmet until the end of the event. The rider must submit another helmet for approval by the Technical Steward. After an accident involving impact, the helmet must be presented to the Technical Steward for examination (see also Art. 77.02.14).

69.03

All helmets must be intact and no alteration must have been made to their construction.

69.04

The Chief Technical Steward and/or the Technical Steward may perform the following checks before the rider is permitted to take part in practice of the race:

69.04.1 That the helmet fits well on the rider's head.

69.04.2 That it is not possible to slip the retention system over the chin, when fully fastened.



69.04.3 That it is not possible to pull the helmet over the rider's head by pulling it from the back of the helmet.

01.70 RECOGNISED HELMET APPROVAL MARKS

Helmets must conform to one of the recognised international standards:

EUROPE	ECE 22-05 or ECE 22-06 (only "P" type)
JAPAN	JIS T 8133:2015 (only "Type 2 Full face")
USA	SNELL M 2015 or SNELL M 2020D or SNELL M 2020R

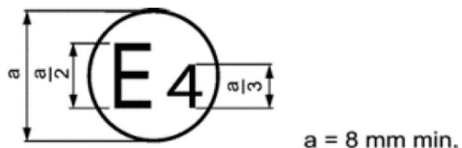
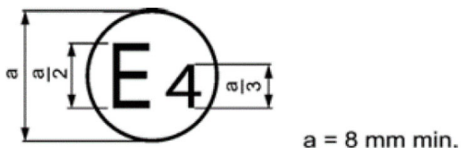
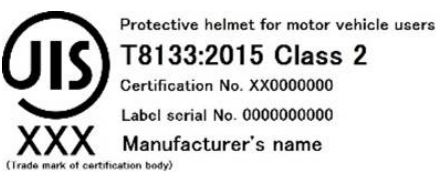
Examples of labels are reported below:

EUROPE	 <p>a = 8 mm min.</p>	 <p>a = 8 mm min.</p>
	051406/P-1952	061406/P-1952
JAPAN		
USA		



01.73 NATIONAL COLOURS FOR HELMETS

In competitions between national teams (e.g. ISDE), it is compulsory that the helmet's overall graphics represent the colours of the team's national flag or the colours as mentioned in the table below. The national flag can be replicated in stripes, bands or other patterns.

Andorra	FMA	White with vertical blue, yellow and red bands
Argentina	CAMOD	White with blue horizontal band
Australia	MA	Green and yellow sides, red, white & blue representation of the Australian flag across the top
Austria	OeAMTC	Bright red with a 60 mm wide black band and the label of the OeAMTC in a white field on the front side
Belgium	FMB	Yellow
Brazil	CBM	Yellow and green
Bulgaria	BMF	Green and red
Canada	CMA	White and 3 Red Maple leaves, one on front and one on each side
Chile	FMC	Red with blue band and yellow stars
China	CMSA	Red and yellow
Czech Republic	ACCR	Blue with red, white and blue border
Denmark	DMU	Red and white
Finland	SML	White with blue cross
France	FFM	Blue
Germany	DMSB	White with black border
Great Britain	ACU	Green
Greece	ELPA	White with blue border
Hungary	MAMS	Red and green
Ireland	MCUI	Green and orange
Italy	FMI	Red with one green and one white horizontal band
Japan	MFJ	White with red circle on top
Kenya	KMSF	Black, Red, Green, with white bands and the country name KENYA on both sides.

Luxembourg	MUL	Purple
Mexico	FMM	White with green and red border
Monaco	MCM	Blue and white
Netherlands	KNMV	Orange
New Zealand	MNZ	White with black kiwi on front
Norway	NMF	Red and blue
Peru	FPEM	Red with 75 mm wide white strips and blue and yellow chequered border
Poland	PZM	White with red band
Portugal	FNM	White
Rumania	FRM	Black with vertical blue, yellow and red bands with national emblem.
Russia	MFR	White with a red border and a vertical red band with star
San Marino	FSM	White with the San Marino National emblem
Slovakia	SMF	Blue, red and white
South Africa	MSA	Black, green, blue and red with yellow and white bands
Spain	RFME	Yellow and red
Sweden	SVEMO	Blue and yellow
Switzerland	FMS	Red with white cross
Uruguay	FUM	Light blue
USA	AMA	Blue with 2 white bands

In addition, the defending FIM Team World Champion is allowed to wear the rainbow colours on the helmet.

The rider's personal sponsors may be part of the overall graphics or displayed in a separate and dedicated area below the goggles strap (usually horizontal). The helmet model of each of the riders of a team may be different, but the graphics must have a similar visual appearance.

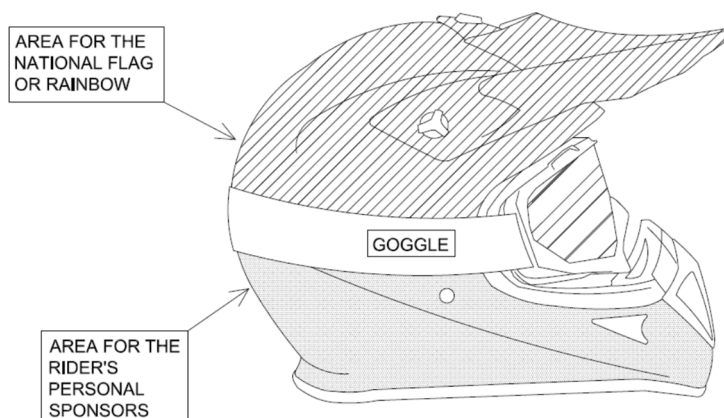

The overall graphics on the helmet must always be approved, in any case, by the FMN of the team.

Whenever a team is using a helmet and there is a case of *force majeure* (e.g. change of rider, broken helmet, etc.), the helmet in question can be replaced by any other helmet, provided that it complies with the FIM Technical Rules for the current year and has been presented to the Technical Stewards of the event.

01.75 BADGE OF THE FIM

Under certain circumstances the FIM may permit the use of the FIM badge on certain equipment in order to show that the latter conforms to the standards laid down by the FIM. When this authorisation is granted and provided the equipment on which it appears is in good condition, the badge is then the guarantee of the conformity with the standard set by the FIM.

01.76 NUMBER SASHES (BIBS)

The starting number on the rider's bib or vest must be the same as on his motorcycle.

Starting numbers must be in conformity with the following specifications:

76.02

The size of the area in which numbers are printed is: 25 x 25 cm maximum.

76.03

Height of number: 15 cm.

76.04

Width of number: 6 cm.

76.05

Width of stroke: 2 cm.

76.06

Only the space outside the 25 x 25 cm area may be used for publicity.

76.07

Bibs manufactured from PLASTIC material are not allowed.

01.77 TECHNICAL VERIFICATIONS

77.01 Preparation

- Prior to the Technical Verifications, it should be decided who is doing what and note decisions. "Efficiency" must be the watchword. Always keep cheerful and remember the reasons for scrutineering: SAFETY AND FAIRNESS.
- Before the START of the competition, a closed and guarded area (closed parc/parc-fermé) shall be prepared.
- Inspection must take place under cover with a large enough area.
- Inspection area must be supplied with the necessary equipment, including tables, chairs, electric light and power outlet.
- Weighing apparatus must be accurate, practical and have a minimum resolution of 100g. Certified master weights and their certificate must be available for verifying.
- The necessary tools are listed below:
 - ✓ Revolution meter
 - ✓ Sound meter, calibrator and spare batteries
 - ✓ Slide calliper (for verifying engine capacity, carburettor diameter, etc.)
 - ✓ Depth gauge
 - ✓ Steel measuring tape
 - ✓ Arrangement for measuring ground clearance (for Sidecars)
 - ✓ Seals
 - ✓ Weighing apparatus (to be furnished by the Organiser) (and set of reference weights)
 - ✓ Tools for measuring the engine capacity
 - ✓ Lampoil tester is recommended and when used, it indicates the cylinder capacity. When a more precise measurement is required, the Chief Technical Steward may ask to take the cylinder head off the cylinder.
 - ✓ Colour for marking parts
 - ✓ Heat resistant stickers or paint for marking the silencer (and solvent)
 - ✓ Magnet
 - ✓ Adequate fuel sample bottles
 - ✓ PC with CD Drive + updated operating system
 - ✓ Printer, etc. are recommended
 - ✓ Calculator
- The necessary documents are listed below:
 - ✓ Supplementary Regulations
 - ✓ FIM Technical Rules - current year
 - ✓ FIM Rules of the discipline concerned
 - ✓ FIM Sporting Code
 - ✓ Homologation papers (if applicable)

- ✓ Writing material
- ✓ Technical Verifications forms
- All necessary measures and administrative equipment should be in place at least 1/2 hour before the start of the Technical Verifications is due to open (time in Supplementary Regulations).

77.02 Verifications

- The Technical Verifications must be carried out in conformity with the procedure and times fixed in the CEN Rules and the Supplementary Regulations of the event.
- The Sound control must be carried out first. The Sound level will be recorded in the technical card. The exhaust silencer will be marked with paint or sticker.
- An example of minimum verifications that shall be performed is given below:

INITIAL TECHNICAL VERIFICATIONS	TRIAL	MOTO CROSS	TRACK RACING	ENDURO	CROSS-COUNTRY RALLIES and BAJAS
Sound	✓	✓	✓	✓	✓
Cut-off switch	✓	✓	✓	✓	✓
Self-closing throttle	✓	✓	✓	✓	✓
Lights (front, rear, brake)	✓*			✓*	✓
Make + model	✓	✓	✓	✓	✓
Race fuel certificate	✓	✓	✓	✓	✓
Vehicle identification plate/chassis number				✓	✓
Crankcase	✓			✓	✓
Wheels (hubs)				✓	✓
Registration plate + insurance (green card)				✓	✓
Weight + ballast	✓	✓	✓		
Fuel tank	✓				✓
Silencer	✓	✓	✓	✓	✓
Carburettor			✓		
Guard for the countershaft sprocket and rear sprocket	✓	✓	✓	✓	✓
Handlebar ends + protection + levers	✓	✓	✓	✓	✓
Front/rear brake disc protection	✓				
Side stand				✓**	✓
Tyres	✓	✓	✓	✓	✓
Helmet(s) + national colors	✓	✓	✓	✓	✓
Protective clothing	✓	✓	✓	✓	✓

* not applicable for closed circuits when specified in the Supplementary Regulations

** not applicable in SuperEnduro

- An overall inspection of the motorcycle must be carried out in conformity with the FIM rules. On accepted motorcycles a sticker or paint will be applied on the front of the main frame, in conformity with Arts. 061.44 or 062.23 of the Enduro Sporting Rules.
- The Technical Verifications will only be carried out when the Technical Verifications form of the motorcycle has been presented by the rider or his mechanic.
- The fuel tank shall contain a minimum amount of fuel for the sound control.
- At the arrival, at the end of the competition, all the marked parts on the motorcycles must be controlled. After control, the machines must be placed in a closed park for 30 minutes after arrival of the last rider from the class concerned, in case a protest is lodged or further examination is required.
- If a motorcycle or a part of a motorcycle has to be verified and completely dismantled, the motorcycle, the part or the group of parts must be sealed and shipped to a place where the required tools are present for a disassembly. The Clerk of the Course/FIM Race Director must take the decision for this operation.
- The disassembly and the verification of the motorcycle or the parts in question must take place in the presence of the Technical Steward, appointed to the event.
- The Organiser will pay the costs for the transportation and for the verification according to Art. 77.02.14 and 77.02.15.
- If a disassembly is required and ordered by the Clerk of the Course/FIM Race Director, following a protest, according to Art. 77.02.14 and 77.02.15, the losing party will incur all the transportation and verification costs, or a part of these costs fixed by the Clerk of the Course/FIM Race Director.

77.03 FMNR Chief Technical Steward and technical stewards

- The Chief Technical Steward must be in attendance at an event one hour before the Technical Verifications are due to begin. He must inform the Clerk of the Course/FIM Race Director and FIM Technical Director, if present, of his arrival.
- The Chief Technical Steward must ensure that all technical stewards appointed for the event carry out their duties in a proper manner. The Chief Technical Steward shall appoint the technical stewards to individual posts for the race, practices and final control.
- Scrutineers can have different tasks, but the team of scrutineers must have a minimum of four persons. The FMNR Chief Technical Steward must be a holder of an FIM SENIOR Technical Stewards Licence and at least one Technical Steward must hold a FIM Technical Stewards Licence. A minimum number of scrutineers is required according to the following:

- Sound test, silencer marking: two
- Machine inspection, helmet and clothing: two

It is recommended to have 2 up to 4 helpers (staff).

- The Sound Control Officer (SCO) must be holder of a valid FIM Technical Steward's license, come with good knowledge and experience of the sound control and application of the test method. The FMNR may propose the services from a special technician (acoustic engineer) if there is no FIM licenced Technical Steward available to act as SCO.
- After the Technical Verifications has been completed the Chief Technical Steward will submit to the Clerk of the Course/FIM Race Direction a list stating the names of the accepted riders, machines and the sound levels.
- During the event, in the arrival and departure areas, the technical steward must control the repairs and changes made to the machines. He must control that no outside assistance is made. He must also control the condition of the machines.
- At individual time checks, the technical steward must control repairs and other technical assistance. He must also control that the machines are marked in order to ensure that no change in motorcycle occurred on the course.
- At the arrival, at the end of each day, the technical steward must check all parts and the condition of the machine. A rider is allowed an extra 30 minutes to repair or replace a silencer and/or exhaust pipe only.
- If a motorcycle is involved in an accident, the Technical Steward must check the machine to ensure that no defect of a serious nature has occurred. However, it is the responsibility of the rider to present his machine for this re-examination together with the helmet and clothing worn.
- The Chief Technical Steward has the right to look/ inspect any part of the motorcycle at any time of the event.
- All technical stewards shall be well informed and shall make sure their FMN has supplied them with all technical "updates" that may have been issued subsequent to the printing of the Technical Rules books.

77.04 FIM Technical Director

- The FIM Technical Director is appointed by the Director of the FIM International Technical Commission in consultation with the Director of the FIM Enduro Commission.
- The FIM Technical Director is not responsible for the technical verifications but will ensure that they are carried out in accordance with the FIM Technical Rules.

- The FIM Technical Director works in cooperation with the FIM Race Director and the FIM Delegate.
- The authority and duties of the FIM Technical Director include but are not limited to (Please, also refer to the FIM Technical Rules):
 - a) The FIM Technical Director will report any concerns or deficiencies relating to the technical verifications to the FIM Race Director and FIM Delegate and present proposals to resolve such concerns.
 - b) The FIM Technical Director is the final arbiter in relation to technical issues at the event.
 - c) The FIM Technical Director will examine with the Chief Technical Steward the motorcycle(s) and the protective equipment of any rider(s) involved in serious or fatal accidents and present a written report to the FIM Delegate.
 - d) The FIM Technical Director will attend all meetings of the Race Direction, but without voting rights.

77.05 Rider and/or mechanic

- The rider must present themselves to the Technical Verifications within the limit stated in the Supplementary Regulations.

The maximum number of persons present at the technical verifications except the rider will be the mechanic and/or the Team Manager.
- A rider remains at all times responsible that his machine and his personal protective gear are in conformity with the FIM Technical Rules for Enduro motorcycles.
- The rider must present a clean motorcycle in conformity to the FIM Enduro Technical Rules.
- A rider must present one motorcycle only.
- The rider must present the rider's protective wear (equipment), e.g. helmet and clothing.
- For preliminary inspection rider have to bring one environmental mat and use it in Parc Fermé underneath of motorcycle in order to protect the ground from dropping liquids (oil, chain spray, fuel etc.). If environmental mats are provided by the organiser, this must be written in the Supplementary Regulation.
- After the marking, riders must confirm his agreement by signing the Technical Verifications Form (Technical Card), which must indicate the frame number. The motorcycles will then be placed immediately in a closed park (Parc Fermé).

- Competitors must retrieve their machines within 30 minutes after the opening of the closed park area, except for the machines that are chosen for disassembly. After this time limit, the closed park officials will no longer be responsible for the machines left behind.
- Any rider failing to report as required by the provisions below may be excluded from the meeting.
- The Clerk of the Course/FIM Race Director may prohibit any person who does not comply with the rules, or any rider who could be a danger to other participants or to spectators, from taking part in the competitions.

01.78 DANGEROUS MACHINES

If, during practice or the race, a Technical Steward finds that a machine is defective and might constitute a danger to other riders, he must immediately notify the Clerk of the Course/FIM Race Director or his deputy. It is their duty to exclude such a machine either from the practice or from the race itself.

01.79 SOUND CONTROL

NOTES:

- EPVs (Group J) are exempted from sound level control.
- All motorcycles must be checked for sound level during the Technical Verifications.

In order to pursue the measures taken to reduce the sound level in favour of environment and in the framework of the 'RIDE QUIET' campaign, a new method for measuring the sound level called "2 metre max" is applied as from 2013 in all 'all-terrain' disciplines.

The technical specifications and the resources to apply such a method, for the use of the technical stewards and officials, are outlined in the present Article.

The "2 metre max" method shows a very good correlation between the sound power level (LWA) issued by motorcycles in full acceleration, and the maximum sound pressure levels measured at proximity of the same motorcycles, with engines at idle and quickly taken to their maximum rotational speeds.

The "2 metre max" method will consist in quantifying not only the sound level produced by the silencer of the exhaust, but the maximum global sound level achieved by the motorcycle when the engine rpm's are raised to the maximum engine speed, limited by a natural regulation (for 2 strokes) or rev limiters (for 4 strokes).

Only the sound levels measured with the "2 meter max" method will be considered by the technical stewards and by the Race Direction/Jury of the event to decide whether the motorcycle is in conformity with the maximum sound levels authorised.

79.01 Preparation of the sound meter

For all FIM Championships and Prizes, all sound meters must have a frequency response According to IEC61672 Section 11 within a limit of plus or minus 2 dBA from 125 to 8000 Hz at 94, 104 and 114 dBA.

Sound level measuring equipment must also include:

- a compatible calibrator, which must be used immediately before testing begins and always just prior to a re-test if a disciplinary sanction may be imposed;
- a tachometer.

Two sets of equipment must be available in case of failure of tachometer, sound level meter or calibrator during the Technical Verifications.

The sound meter shall be prepared by applying the following procedure:

- Activate the 'A' weighing
- FAST time weighting must be activated
- Select the highest range available (ex. 80~130 dB)
- Calibrate the sound meter according to the instructions, taking into account the incidence of the wind foam ball
- Position the wind foam ball on the microphone
- Activate the function MAX MIN – set on MAX

79.02 Set up of the sound meter and the motorcycle

The sound levels will be measured with the microphone fixed on a tripod at a height of 1.35 m above the ground, in horizontal (levelled) position. It is helpful to have the microphone equipped with an extension cable to the sound meter.

For the place and position of the motorcycle, ensure that there are no solid obstacles within 10 m around the microphone.

Depending on the vehicle, the sound meter will be positioned

- for Solo motorcycles (except for Snowmobiles): at an angle of 45° from the longitudinal axis of the vehicle, on the exhaust side, at a distance of 2 m behind the vehicle (measured from the point where the centre of rear tyre touches the ground).
- for Solo motorcycles with 2 exhaust outputs: at an angle of 45° from the longitudinal axis of the vehicle, on the side of the air intake, at a distance of 2 m behind the vehicle (measured from the point where the centre of rear tyre touches the ground). Note: if a central positioned air intake is used, both sides will be tested.
- for Snowmobiles: at an angle of 90° from the longitudinal axis of the vehicle, on the side of the silencer, at a distance of 2 m next to the vehicle (measured from the silencer exit). For continuity of the measurement, use the handlebar as a reference to line up the machine with the microphone - the exhaust pipe is usually located on the right hand side of the machine and directly under the

handlebar position. Note: the use of only one silencer is allowed for Snowmobiles.

- ~~for Sidecars: at an angle of 45° from the longitudinal axis of the vehicle, on the sidecar side, at a distance of 2 m behind the vehicle (measured from the point where the sidecar tyre touches the ground). If the exit of the silencer is closer to the motorcycle rear wheel, the reference point will be the contact point of the motorcycle rear wheel on the ground (as for Solo motorcycles).~~
- for Quads: at an angle of 45° from the median longitudinal axis of the vehicle, at a distance of 2 m behind the vehicle (measured from the point where the line drawn perpendicular to the rear axle touches the ground).
- for Quads with the exhaust moved out of the median axis: at an angle of 45° from the exhaust axis, on the offset side, at a distance of 2 m behind the vehicle (measured from the point where the line drawn perpendicular to the rear axle touches the ground).

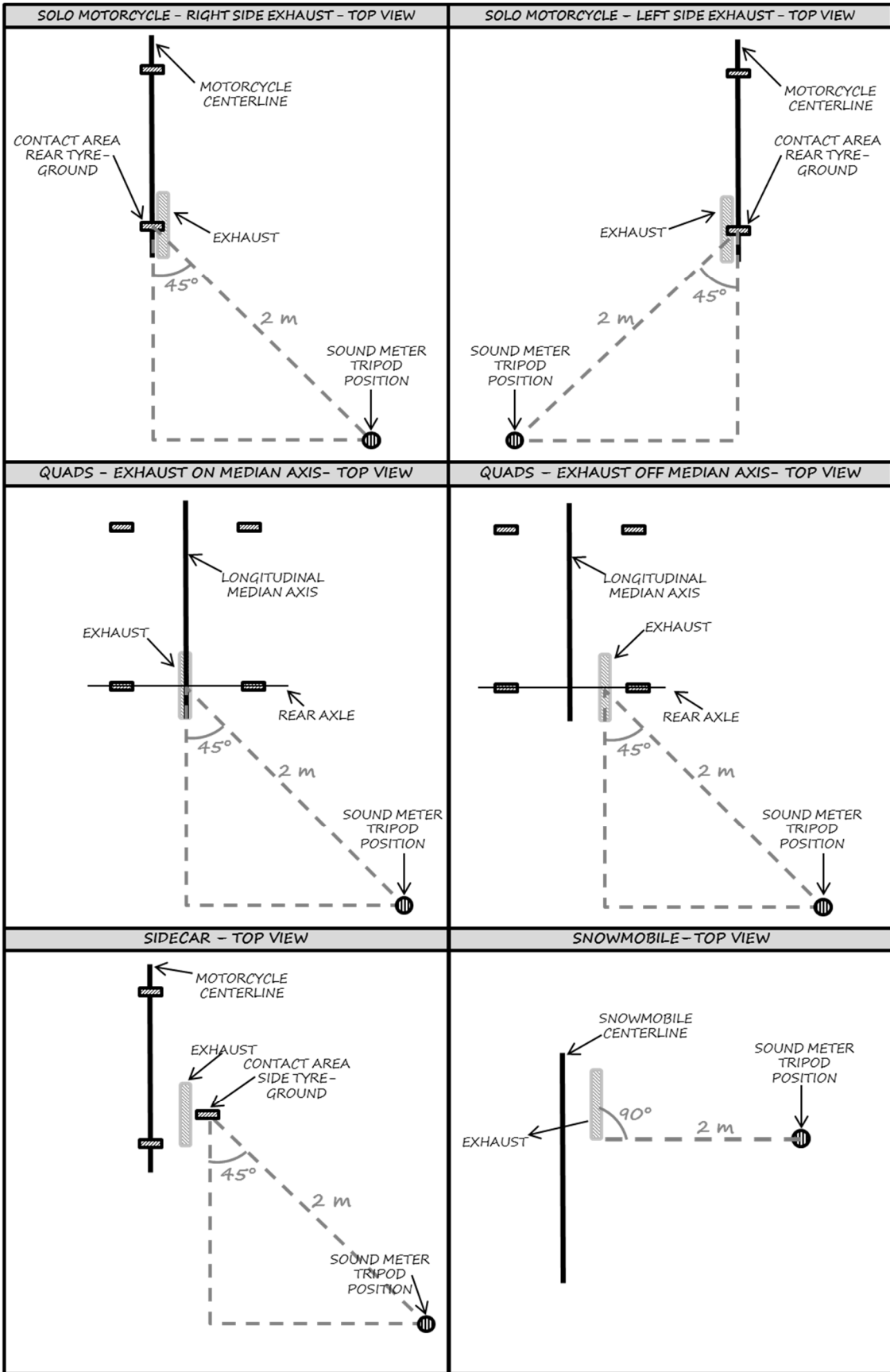

The sound level for engines with more than one silencer will be measured on each exhaust end.

Silencers fitted with adapters aiming to reduce the sound level shall be permanently fitted.

To make repetitive measurements, all motorcycles can be positioned into a small frame fixed on the ground, making sure to respect the 45° requirements. A squared frame helps the positioning of the motorcycle.

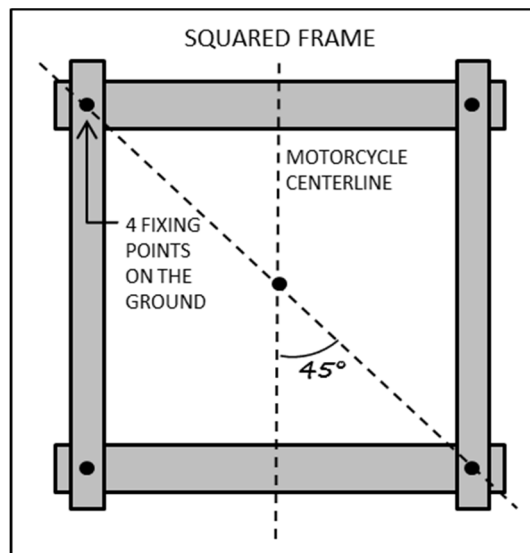

Vehicles which are not equipped with a gear box neutral must be placed on a stand.

It is preferred to make the tests on soft ground, not reverberating, i.e. grass or fine gravel.

In other than moderate wind, machines should face forward against the wind direction.

The ambient sound at the point of measurement must be minimum 15 dBA less than the lowest FIM sound limit applied in each discipline.

It is recommended to regularly re-calibrate the sound meter during the test day.

79.03 The test procedure

A technical steward (nominated as Sound Control Officer, "SCO", see 77.03) takes place next to the vehicle, opposite to the sound meter/microphone, in order not to screen or stand between the bike and the microphone.

The Sound Control Officer (SCO) must have arrived in sufficient time for discussions with the Clerk of the Course/FIM Race Director and other Technical Officials in order that a suitable test site and testing procedure can be agreed.

A second technical steward can be present to help. The rider can also be present.

It is strongly advised that the technical steward(s) use earplugs, a headset or ear protectors.

The measurement is made with motorcycle on its wheels, with a hot engine. During the sound test, only the rider may sit on the vehicle in the normal riding position.

A rider or a mechanic, placed on the left side of the motorcycle, shall disengage the clutch.

The SCO (and not others) shall open the throttle as fast as possible (instantly, within 0.3 s) until "full open throttle", in order to reach the maximum rpm value ("max. rpm").

- For Motocross, Enduro/SuperEnduro, Cross-country rallies/Bajas and Track Racing motorcycles with no FIM homologated silencers, the "max rpm" is the one defined by the ECU (for 4-stroke engines), or by a natural regulation (for 2-stroke engines).

When in doubt, it can be verified that such "max. rpm" value is higher than the rpm value at which the vehicle supplies its maximum power (kW) ("max. power rpm").

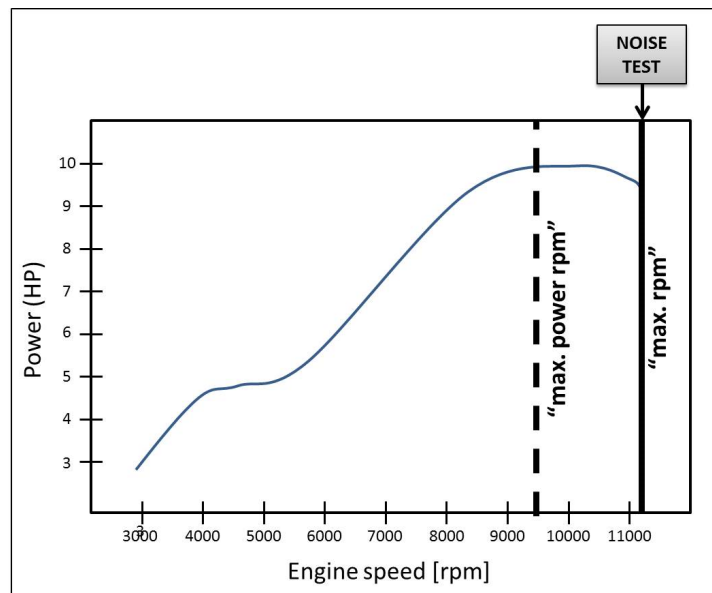

- For Trial, the "max rpm" is established at 10000 (± 200) rpm and obtained thanks to a dedicated "sound test" mapping of the internal ECU or an external one, purpose-made and connected in occasion of the test.
- For Track-Racing with FIM homologated silencers, when sound tests are needed, the "max rpm" is established at 11000 (± 500) rpm.

The SCO then keeps the engine at the "max. rpm" value for at least 1 s (or until there is an audible sign of over-revving the engine), during which the measurement is taken.

To conclude the test, the SCO releases the throttle quickly.

The maximum noise value (dB/A) registered during the measurement interval is then read on the sound meter and recorded. This noise value shall not be rounded down to the nearest whole number.

The noise value is then compared with the sound limits (see Art. 79.04).

The noise test can be "PASSED" or "NOT PASSED":

- "PASSED": The sound test is considered "passed" if the recorded noise value is below or equal to the sound limits of Art. 79.04. The silencer can then be marked by the SCO at the end of the test.

The silencer shall not be changed after verification.

The end opening of the silencer shall remain unmodified once it has been checked and marked.

- "NOT PASSED": The sound test is considered "not passed" if the recorded noise value is above the sound limits of Art. 79.04.
In this case, the vehicle (with the same silencer) can be presented again, but for two more tests maximum.
If the third test result is negative, the rider
 - can present a different or repaired silencer (in case the sound test was done before the race)
 - will receive a penalty (in case the sound test was done during or after the race).

The sound meter is then reset by pushing on the side-line and armed by pushing on the side-line again.

Notes:

- If the engine starts to misfire, close the throttle slightly and re-open the throttle.
- If detonations appear, the measurement must be started again.
- For vehicles without an engine rev. limiter, the throttle will have to be opened not more than 2 s or until there is an audible sign of over-revving the engine.
- Even in case a vehicle has not exceeded the respective sound limit, if there is any doubt, the vehicle may be checked again.
- If the vehicle is unable to reach the "max. power rpm" value, the vehicle shall be refused. Any attempt by a participant to prevent his engine from reaching the "max. power rpm" will be considered a breach of the rules.
- In case the SCO doubts that the "max. power rpm" value (as declared by the manufacturers or previously obtained with the dyno test), he/she shall measure the engine speed with a tachometer connected to the spark.

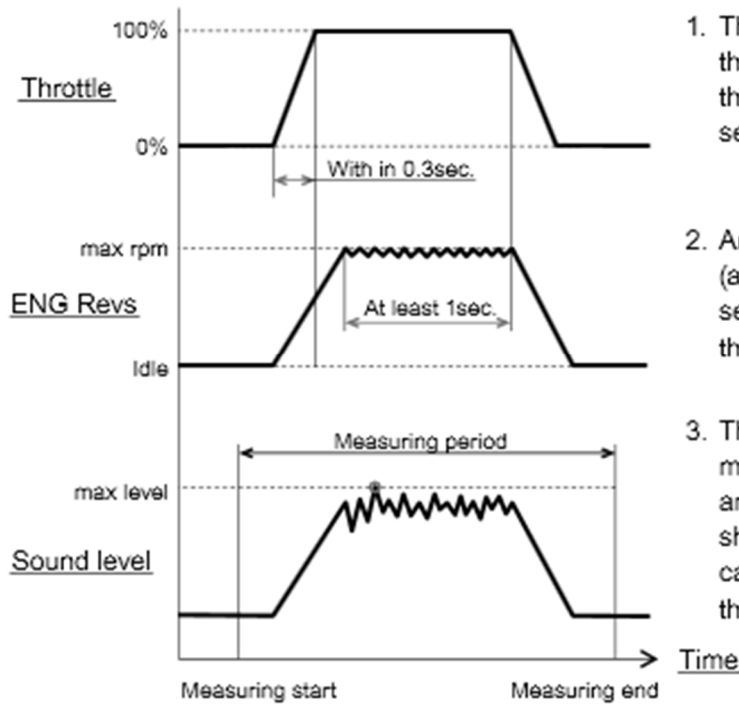

1. The Inspector shall open the throttle until full open throttle within 0.3 seconds.
2. And keep at the max rpm (at rpm limiter) at least 1 second. Then, release the throttle quickly.
3. The sound level is measured in the all period and the maximum level shall be recorded in any case. (automatically by the sound meter).

79.04 Sound limits

ENDURO and ISDE World Championships, Cups and Prizes	
Maximum Sound limit	
Before race	During or after race
114.0 dB/A	115.0 dB/A

NOTES:

- The values that have to be respected after the race take into account the degradation of the silencer (i.e. the limit is raised of 1 dB/A).
- The values already take into account the accuracy of the method.
- No deductions for ambient temperature, pressure or altitude are allowed.
- The measured noise value shall not be rounded down to the nearest whole number.

79.06

Action and decisions will depend on the Sporting Discipline concerned, and decisions taken during prior discussions with the FIM Technical Director and/or the Chief Technical Steward.

Diagrams

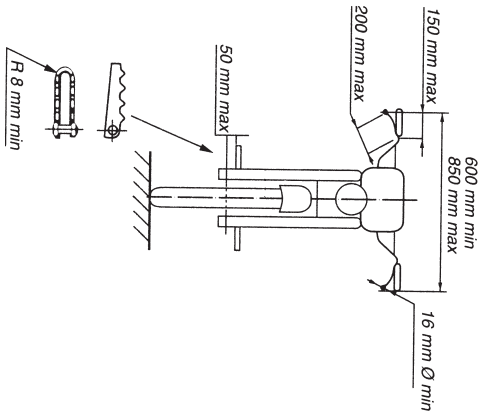
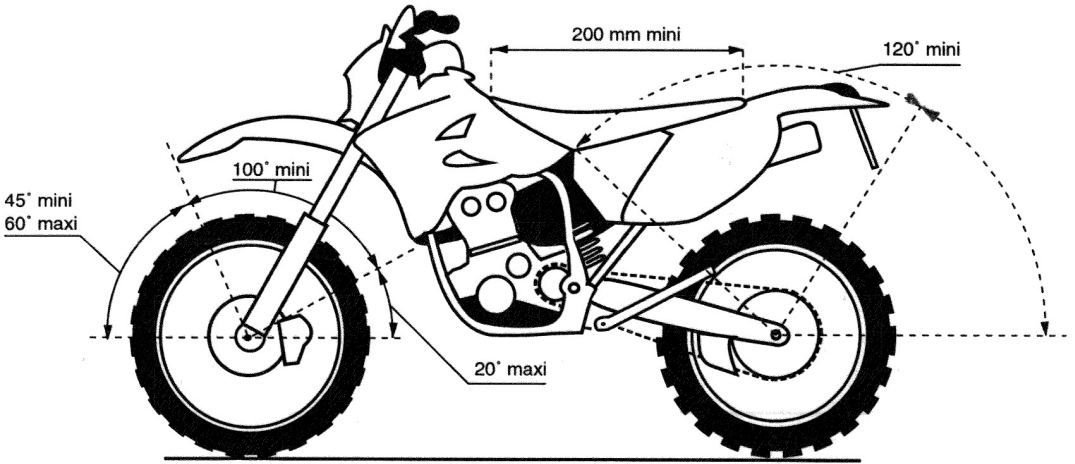

Art. 51.06
Example:
Studs/Clous

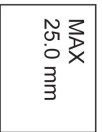
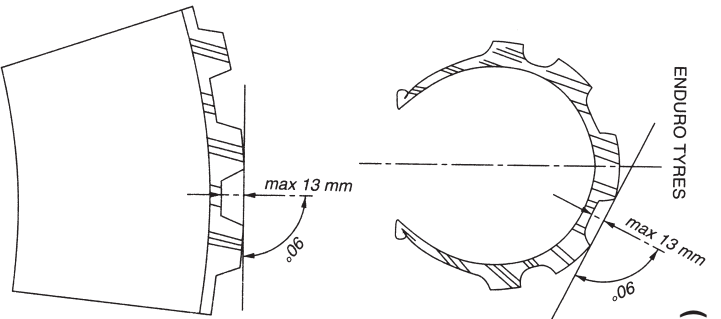
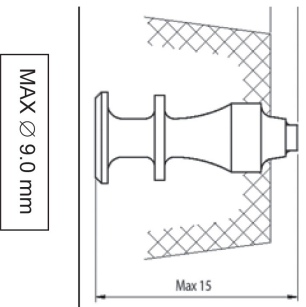

NUMBERS/NÚMEROS

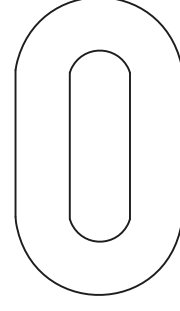
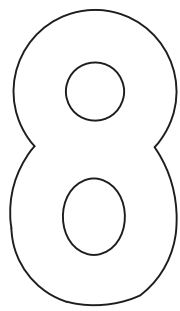
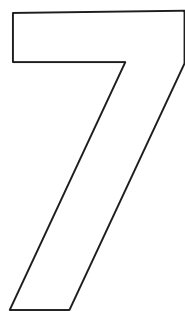
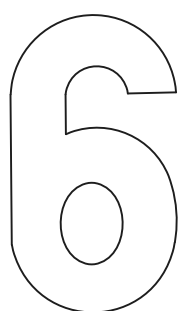
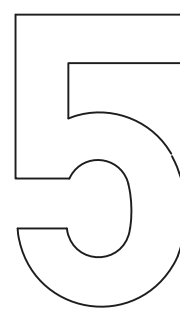
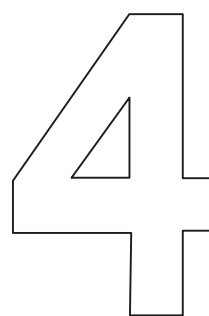
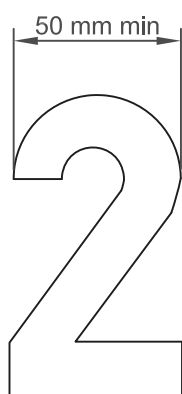
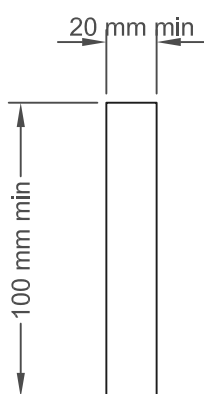
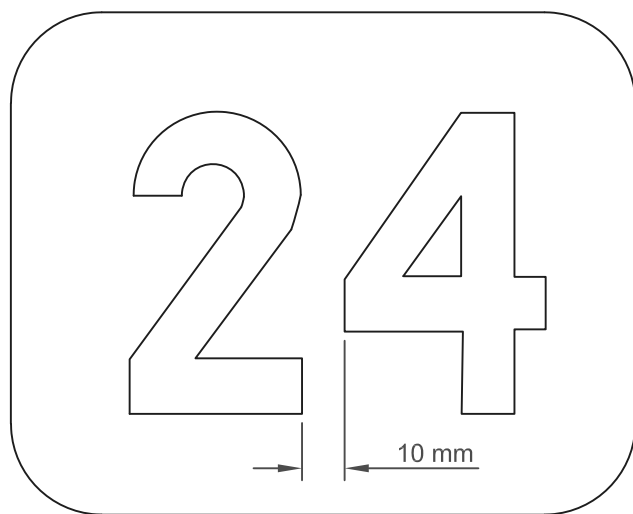

TEN FITTING TESTS FOR HELMETS **DIX TESTS D'ADAPTATION POUR LES CASQUES**

1. *Obtain correct size by measuring the crown of the head*
Avoir la bonne grandeur en mesurant le sommet de la tête
2. *Check there is no side to side movement*
Vérifier qu'il n'y ait pas de déplacement d'un côté à l'autre
3. *Tighten strap securely*
Serrer solidement la jugulaire
4. *With head forward, attempt to pull up back of helmet to ensure helmet cannot be removed this way*
Tête en avant, essayer de soulever le casque pour s'assurer qu'il ne peut pas être enlevé de cette façon



5. *Check ability to see clearly over shoulder*
Vérifier si vous pouvez voir clairement par-dessus l'épaule
6. *Make sure nothing impedes your breathing in the helmet and never cover your nose or mouth*
S'assurer que rien ne gêne votre respiration dans le casque et ne jamais couvrir le nez ou la bouche
7. *Never wind scarf around neck so that air is stopped from entering the helmet. Never wear scarf under the retention strap*
Ne jamais enrouler une écharpe autour du cou, car cela empêche l'air d'entrer dans le casque. Ne jamais porter d'écharpe sous la jugulaire
8. *Ensure that visor can be opened with one gloved hand*
S'assurer que la visière peut être ouverte avec une main gantée
9. *Satisfy yourself that the back of your helmet is designed to protect your neck*
S'assurer que l'arrière de votre casque a une forme telle qu'il vous protège la nuque
10. *Always buy the best you can afford*
Toujours acheter le meilleur que vous pouvez vous offrir



FÉDÉRATION INTERNATIONALE
DE MOTOCYCLISME

FIM-MOTO.com

11, ROUTE DE SUISSE | CH - 1295 MIES
cti@fim.ch

65 790 04