



FÉDÉRATION INTERNATIONALE
DE MOTOCYCLISME

**RÈGLEMENTS
TECHNIQUES**

SECTION GÉNÉRALE

**TECHNICAL
RULES**

GENERAL SECTION

MOTOCROSS

*(RÈGLEMENTS POUR QUADS
& MOTONEIGE INCLUS)*

MOTOCROSS

*(INCLUDING RULES FOR QUADS
& SNOWCROSS)*

2011

TRIAL

ENDURO

*(RÈGLEMENTS POUR RALLYES
TOUT TERRAIN INCLUS)*

**COURSES
SUR PISTES**

*(RÈGLEMENTS POUR
MOTOBALL INCLUS)*

TRIAL

ENDURO

*(INCLUDING RULES
FOR CROSS-COUNTRY RALLIES)*

**TRACK
RACING**

*(INCLUDING RULES
FOR MOTOBALL)*

Technical Rules
Règlements Techniques
General Section/Section générale

Motocross
(Including Rules for Quads and Snowcross)
(Règlements pour Quads et Motoneige inclus)

Trial

Enduro

Track Racing
Courses sur Pistes
(Including Rules for Motoball)
(Règlements pour Motoball inclus)

Sommaire / Contents

Appendix	01	Technical Rules – General Section	1-46
Annexe	01	<i>Règlements Techniques – Section générale.....</i>	<i>1-46</i>
Appendix	01	Motocross Technical Rules (including Quads and Snowcross).....	48-82
Annexe	01	<i>Règlements Techniques Motocross (Quads et Motoneige inclus).....</i>	<i>48-82</i>
Appendix	01	Trial Technical Rules.....	83-102
Annexe	01	<i>Règlements Techniques Trial</i>	<i>83-102</i>
Appendix	01	Enduro Technical Rules	103-124
Annexe	01	<i>Règlements techniques Enduro.....</i>	<i>103-124</i>
Appendix	01	Track Racing Technical Rules (including Motoball)	125-187
Annexe	01	<i>Règlements techniques de Courses sur Pistes (y compris Motoball)</i>	<i>125-187</i>

Cross-Country Rallies Technical Rules are exceptionally published within the Cross-Country Rallies Sporting Appendices.

Les Règlements Techniques des Rallyes Tout Terrain sont exceptionnellement publiés dans les Annexes Sportives des Rallyes Tout Terrain.

Articles amended as from 01.01.2011 are in bold type
Les articles modifiés dès le 01.01.2011 sont en caractères gras

Technical Rules General Section

Règlements Techniques Section générale

These articles, from 01.01 until 01.81 apply to all the disciplines hereafter.
Ces articles, de 01.01 à 01.81 s'appliquent à toutes disciplines ci-apres.

TECHNICAL RULES – GENERAL SECTION

Table of contents

01.01	INTRODUCTION.....	2
01.03	FREEDOM OF CONSTRUCTION.....	2
01.05	CATEGORIES AND GROUPS OF MOTORCYCLES.....	2
01.07	CLASSES.....	3
01.11	MEASUREMENT OF CAPACITY.....	4
01.17	SUPERCHARGING.....	5
01.18	TELEMETRY.....	5
01.19	MOTORCYCLE WEIGHTS.....	5
01.21	DESIGNATION OF MAKE.....	6
01.23	DEFINITION OF A PROTOTYPE.....	6
01.25	GENERAL SPECIFICATIONS.....	6
01.26	DEFINITION OF A FRAME OF A SOLO MOTORCYCLE.....	8
01.27	STARTING DEVICES.....	8
01.29	OPEN TRANSMISSION GUARDS.....	8
01.31	EXHAUST PIPES.....	8
01.33	HANDLEBARS.....	9
01.35	CONTROL LEVERS.....	10
01.37	THROTTLE CONTROLS.....	10
01.39	FOOTRESTS.....	11
01.41	BRAKES.....	11
01.43	MUDGUARDS AND WHEEL PROTECTION.....	11
01.45	STREAMLINING.....	11
01.47	WHEELS, RIMS, TYRES.....	12
01.49	TYRES.....	12
01.50	ADDITIONAL SPECIFICATIONS FOR ELECTRIC POWERED VEHICLES.....	12
01.53	ADDITIONAL SPECIFICATIONS FOR SIDECARS.....	20
01.55	NUMBER PLATES.....	22
01.63	FUEL, FUEL/OIL MIXTURES.....	22
01.65	EQUIPMENT AND PROTECTIVE CLOTHING.....	29
01.67	WEARING OF HELMETS.....	30
01.69	HELMET OPERATIVE INSTRUCTIONS.....	30
01.70	RECOGNISED INTERNATIONAL APPROVAL MARKS.....	31
01.71	EYE PROTECTION.....	31
01.73	NATIONAL COLOURS FOR HELMETS.....	32
01.75	BADGE OF THE FIM.....	33
01.76	NUMBER SASHES (BIBS).....	34
01.77	CONTROL.....	34
01.79	SOUND CONTROL.....	35
01.80	GUIDELINES FOR USE OF SOUND LEVEL METERS.....	42
01.81	TIME KEEPING.....	43
	DIAGRAMS.....	45

01.01 INTRODUCTION

The term motorcycle covers all vehicles having, in principle, less than four wheels, propelled by an engine and designed essentially for the carriage of one or more persons of which one is the rider of the vehicle. The wheels must normally be in contact with the ground except momentarily or in certain exceptional circumstances. Furthermore, in order to traverse certain surfaces one or all of the wheels can be replaced with skis, rollers or chains.

01.03 FREEDOM OF CONSTRUCTION

A motorcycle must conform to the requirements of the FIM regulations, to the Supplementary Regulations, as well as to a number of specific conditions that the FIM may require for certain competitions. No restriction is placed on the make, construction or type of motorcycle used.

All solo motorcycles (Group A) must be constructed in such a way that they are entirely controlled by a rider. Motorcycles with Sidecars (Group B) must be constructed to carry a passenger.

01.05 CATEGORIES AND GROUPS OF MOTORCYCLES

Motorcycles are divided into categories which must be observed for all meetings and world record attempts.

In principle, it is forbidden for different categories, groups and classes to compete in the same race, unless the Supplementary Regulations state otherwise.

Category I

Motorcycles propelled by the action of one wheel in contact with the ground.

Category II (not applicable for Track Racing)

Special vehicles propelled by the action of one or more wheels in contact with the ground but which are not covered by the conditions of Category I.

Group A1 - Solo Motorcycles

2-wheel vehicles making only one track on the ground.

Group B1

Vehicles with three wheels, making two tracks on the ground, consisting of a motorcycle making one track and a Sidecar for a passenger making the other.

Group B2

Vehicles with three wheels, making two or three tracks on the ground in the direction of forward travel, with a permanently attached Sidecar forming a complete integral unit.

If three tracks are made, the centre-line of the two tracks made by the motorcycle wheels must not be more than 75 mm apart. A track is determined by the longitudinal centre-line of each of the vehicle's wheels in the direction of forward travel.

Category II (not applicable for Track Racing)

Group C	-	Special 2 wheel driven motorcycles
Group D	-	Special 3 wheel, 2 wheel driven motorcycles
Group E	-	Snowmobiles
Group F	-	Sprinters and Dragsters
Group G	-	Quad Racers
Group H	--	
Group I	--	

Category III (not applicable for Track Racing)

Group J	-	Electric Vehicles (see Article 01.50)
---------	---	--

01.07 CLASSES

Groups are again separated into classes according to cylinder capacities as detailed below. Generally, these classes must be observed for all meetings.

For specific details, refer to this article of each discipline (CMS, CTR, **CEN**, CCP).

01.11 MEASUREMENT OF CAPACITY**11.11 Reciprocating movement engine, "Otto" Cycle**

The capacity of each engine cylinder is calculated by the geometric formula which gives the volume of a cylinder; the diameter is represented by the bore, and the height by the space swept by the piston from its highest to lowest point:

$$\text{Capacity} = \frac{D^2 \times 3.1416 \times C}{4}$$

where D = bore
and C = stroke

When a cylinder bore is not circular the cross sectional area must be determined by a suitable geometrical method or calculation, then multiplied by the stroke to determine capacity.

When measuring, a tolerance of 1/10 mm is permitted in the bore. If with this tolerance the capacity limit is exceeded for the class in question, a further measurement should be taken with the engine cold, to 1/100 mm limits.

11.13 Rotary engines

The capacity of an engine which determines the class in which the motorcycle shall compete in a meeting shall be calculated by:

$$\text{Capacity} = \frac{2 \times V}{N}$$

where V = total capacity of all the chambers comprising the engine
and N = number of turns of the motor necessary to complete one cycle in a chamber.

Classified as a 4-stroke.

11.15 Wankel system

For Wankel system engines with a triangular piston, the capacity is given by the formula:

$$\text{Capacity} = 2 \times V \times D$$

where V = capacity of a single chamber
and D = number of rotors.

This engine is classified as a 4-stroke.

01.17 SUPERCHARGING

Supercharging by means of a device of any kind is forbidden in all meetings.

An engine whether 2-stroke or 4-stroke coming within any one of the recognised classes (determined by the capacity of the working cylinder) shall not be considered as supercharged when in respect of one engine cycle, the total capacity measured geometrically, of the fuel charging device or devices, including the capacity of the working cylinder (if used for injecting the fuel), does not exceed the maximum capacity of the class in question.

01.18 TELEMETRY

Information must not be transmitted in any way to or from a moving motorcycle. An official signalling device may be required on the machine. Automatic lap timing devices are not considered as "telemetry". Automatic lap timing devices must not disrupt any official time keeping methods and equipment.

01.19 MOTORCYCLE WEIGHTS Weights of motorcycles without fuel

19.01

A 1 % tolerance in the weight of the machine after the race is accepted.

For specific details, refer to this article of each discipline (CMS, CTR, CEN, CCP).

19.03

Seals must be fixed to the front main frame.

19.04

Weighing scales must be certified annually by a National Institute.

19.05

For Groups B1 and B2 at all competitions a passenger must be carried.

01.21 DESIGNATION OF MAKE

When two manufacturers are involved in the construction of a motorcycle the name of both must appear on the machine as follows :

- The name of the chassis manufacturer
- The name of the engine manufacturer

This applies where no commercial interests are involved.

01.23 DEFINITION OF A PROTOTYPE

A prototype motorcycle is a vehicle which must conform to the safety requirements as required by the FIM Sporting Code and Appendices applicable to the type of competition for which it is to be used.

01.25 GENERAL SPECIFICATIONS

The following specifications apply to all vehicles of the groups indicated and to all types of competitions except where otherwise stated in the corresponding section of the FIM Sporting Code.

They should also be applied to all national competitions unless the FMNR (National Motorcycling Federation) has otherwise directed.

Further specifications for some competitions may also be required and these will be detailed in either the appropriate FIM Appendix or in the Supplementary Regulations for the competition in question.

25.01

The use of titanium in the construction of the frame, the front forks, the handlebars, the swinging arms, the swinging arm spindles and the wheel spindles is forbidden.

The use of light alloys for wheel spindles is also forbidden (except for Trial motorcycles).

The use of titanium alloy nuts and bolts is allowed.

Titanium test to be performed at trackside:

25.01.1 Magnetic test (titanium is not magnetic).

25.01.2 3 % nitric acid test (Titanium does not react. If metal is steel, the drop will leave a black spot).

25.01.3 Specific mass of titanium alloys 4,5-5, of steel 7,5-8,7 can be ascertained by weighing the part and measuring its volume in a calibrated glass vessel filled by water (intake valve, rocker, connecting rod, etc.)

25.01.4 In case of doubt, the test should take place at a Materials Testing Laboratory.

25.02

Aluminium alloys can be ascertained visually.

25.06

The number of cylinders in an engine is determined by the number of combustion chambers.

25.07

If separate combustion spaces are used they must be connected by an unrestricted passage of minimum cross sectional area at least 50 % of the total inlet port area.

01.26 DEFINITION OF A FRAME OF A SOLO MOTORCYCLE

The structure or structures used to join any steering mechanism at the front of the machine to the engine/gear box unit and to all components of the rear suspension.

01.27 STARTING DEVICES

For specific details, refer to this article of each discipline (CMS, CTR, **CEN**, CCP).

01.29 OPEN TRANSMISSION GUARDS

For specific details, refer to this article of each discipline (CMS, **CEN**, CTR, CCP).

01.31 EXHAUST PIPES

Exhaust pipes and silencers must fulfill all the requirements concerning sound control (see also Art. 01.79).

31.01

The end of the silencer must be horizontal and parallel (over a minimum distance of 30 mm) to the central axis of the solo motorcycle (with a tolerance of $\pm 10^\circ$) and must not exceed the end of the silencer body by more than 5 mm. All sharp edges must be rounded with a minimum radius of 2 mm (See diagram E).

31.02

Exhaust fumes must be discharged towards the rear but not in a manner as to raise dust, foul the tyres or brakes, or inconvenience a passenger, if there is one, or any other riders.

All possible measures must be taken to prevent the possible loss of waste oil so that it does not inconvenience a following rider.

31.03

The extremity of the exhaust pipes on solo motorcycles must not pass the vertical tangent of the rear tyre.

31.04

On a Sidecar machine the exhaust must discharge horizontally and towards the rear, at a maximum angle of 30° to the axis of the machine.

01.33 HANDLEBARS**33.01**

The width of handlebars (solo and Sidecars) is: not less than 600 mm and not more than 850 mm.

33.02

The handlebars must be equipped with a protection pad on the cross bar. The handlebars without cross member must be equipped with a protection pad located in the middle of the handlebars, covering widely the handlebars clamps.

33.05

Exposed handlebar ends must be plugged with a solid material or rubber covered.

33.08

Solid stops (other than a steering damper) must be fixed in order to assure a minimum space of 30 mm between the handlebars with its levers and the fuel tank when on full lock to prevent trapping the rider's fingers.

33.09

Handlebar clamps must be very carefully radiused and engineered so as to avoid fracture points in the bar.

33.10

If hand protectors are used they must be of a shatter-resistant material.

33.11

The repair by welding of light alloy handlebars is prohibited.

33.12

Handlebars made from carbon/carbon, carbon/Kevlar or other composite materials are not authorised.

01.35 CONTROL LEVERS**35.01**

All handlebar levers (clutch, brake, etc.) must be in principle ball ended (diameter of this ball to be at least 16 mm). This ball can also be flattened, but in any case the edges must be rounded (minimum thickness of this flattened part 14 mm). These ends must be permanently fixed and form an integral part of the lever.

35.03

Each control lever (hand and foot levers) must be mounted on an independent pivot.

35.04

The brake lever if pivoted on the footrest axis must work under all circumstances, such as the footrest being bent or deformed.

01.37 THROTTLE CONTROLS**37.01**

Throttle controls must be self-closing when not held by the hand.

37.02 Ignition cut-out switches

For specific details, refer to this article of each discipline (CMS, CTR, **CEN**, CCP).

37.03

Solo motorcycles must be equipped with a functional ignition kill switch or button mounted on either right or left side of handlebar (within reach of the hand while on the hand grips) that is capable of stopping a running engine (for Track Racing motorcycles, please refer to this article in the CCP section).

01.39 FOOTRESTS

For specific details, refer to this article of each discipline (CMS, CTR, **CEN**, CCP).

01.41 BRAKES

41.01

All motorcycles must have at least 2 efficient brakes (one on each wheel) operated independently and operating concentrically with the wheel.

41.02

Vehicles in Group B must be fitted with at least 2 efficient brakes operating on at least 2 of the wheels and operated independently and operating concentrically with the wheels.

01.43 MUDGUARDS AND WHEEL PROTECTION

Motorcycles must be fitted with mudguards.

43.01

Mudguards must project laterally beyond the tyre on each side.

43.02

The front mudguard must cover the circumference of the wheel at an angle sufficient enough to protect the rider from mud.

For specific details, refer to this article of each discipline (CMS, CTR, **CEN**, CCP).

01.45 STREAMLINING

No type of streamlining is allowed (see diagrams), with the exception of motorcycles in Cross Country Rallies.

Radiator covers (shields) must be made of flexible materials only (i.e. plastic).

01.47 WHEELS, RIMS, TYRES**47.01**

All tyres will be measured mounted on the rim at a pressure of 1 kg/cm (14 lb./sq.in.); measurements taken at a tyre section located 90° from the ground.

47.02

Any modification to the rim or spokes of an integral wheel (cast, moulded, riveted) as supplied by the manufacturer or of a traditional detachable rim other than for spokes, valve or security bolts is prohibited except for tyre retention screws sometimes used to prevent tyre movement relative to the rim. If the rim is modified for these purposes, bolts, screws, etc., must be fitted.

01.49 TYRES

For specific details, refer to this article of each discipline (CMS, CTR, **CEN**, CCP).

**01.50 ADDITIONAL SPECIFICATIONS
FOR ELECTRIC POWERED VEHICLES****50.01 INTRODUCTION**

The technical concept is reserved for motorcycles propelled by non thermal energies without zero toxic/noxious emissions and by the action of one wheel in contact with the ground.

Amendments to these technical regulations may be made at any time in order to ensure fair competitions.

50.02 GENERAL EPV CLASS REQUIREMENTS

Two and/or three wheeled electric propelled machines, powered solely by stored electricity (battery /accumulator).

The number of electric motors is limited to one.

50.02.1 Race Procedures

(Race procedures to be defined by the Sporting Commission concerned).

50.02.2 Race Format (Guidelines – actual race format depends on the discipline concerned.)

Minimum race length: 20 minutes

Maximum race length: 30 minutes

50.02.3 Charging the accumulator

The vehicle's accumulators must be charged at the times and locations determined by the organiser of the meeting.

Charging may only be done with the energy supply provided by the race organiser.

The charging system must be separate from the machine and comply with all electrical safety requirements including thermal overload trip, fusing and be equipped with an earth leakage protection breaker.

50.02.4 Pit Stop

Riders will be allowed to define their own method of energy renewal subject to safety and practical considerations subject to the approval of the race organiser.

Riders who wish to have a pit stop must declare the process and technology to the Technical Director/Chief Technical Steward for a safety evaluation. All information will be treated with strict confidentiality.

50.02.5 Transponder timing

All machines must be equipped with an official transponder.

50.02.6 Technical Control

As a condition of entry, a Technical Construction File of the motorcycle entered may be required with a race entry, using the template provided (ref: FIM Technical Construction file). This document must provide the basic information listed, as well as the design steps taken to ensure safety for the rider(s), teams, spectators, officials and marshals.

The Technical Officer shall check both the machine and the rider for compliance with the technical specifications, as well as the employment of good engineering construction practice, the provision of adequate electrical insulation and weatherproofing.

Damaged machines must be returned to the technical control area for examination after race or practice. In such circumstances it is the responsibility of the competitor to ensure both his machine and clothing have been rechecked and approved before further use in the event.

It is the responsibility of the rider to ensure that a machine used in competition is electric, mechanically and structurally in a safe condition.

50.02.7 Conformity

It is the duty of each competitor to show the Technical Stewards of the meeting that his/her vehicle fully complies with these rules and the rules governing the meeting, in their entirety at all times.

50.03 SPECIFICATIONS

50.03.1 Requirements

All motorcycles must comply in every respect with all the requirements for racing as specified in the FIM General Technical Specifications, unless specified hereunder.

50.03.2 Number Plates and Colours

For specific refer to this article of each discipline (CMS, CTR, **CEN**, CCP).

Colours: Green background – yellow numbers

50.03.3 Handlebars

For specific refer to this article of each discipline (CMS, CTR, **CEN**, CCP).

50.03.4 Control levers

For specific refer to this article of each discipline (CMS, CTR, **CEN**, CCP).

50.03.5 Foot Rest/Foot Controls

For specific refer to this article of each discipline (CMS, CTR, **CEN**, CCP).

50.03.6 Wheel and rims

For specific refer to this article of each discipline (CMS, CTR, **CEN**, CCP).

50.03.7 Tyres

For specific refer to this article of each discipline (CMS, CTR, **CEN**, CCP).

50.03.8 Streamlining

For specific refer to this article of each discipline (CMS, CTR, **CEN**, CCP).

50.03.9 Machine Weight

Minimum weight: 75 kg. The maximum weight limit shall not exceed 120 kg.

The machine will be checked for weight in the 'ready-to-race' condition. The verified weight may never fall below the required minimum weight.

50.03.10 Overall Dimensions

For specific refer to this article of each discipline (CMS, CTR, **CEN**, CCP).

50.04 ELECTRICAL EQUIPMENT

50.04.1 IEC Publications

If no specific rule exists in these Technical Rules, the relevant IEC Standard (International Electro-technical Commission Standard) or Report has to be observed:

(Note: IEC Publications may be replaced by ISO publications, in the future.)

- IEC 60529: Degrees of protection provided by enclosures (IP Code).

- IEC 60783: Wiring and connectors for the road vehicles.

This report is applicable to cabling and connectors used in battery electric road vehicles.

- IEC 60784: Instruments for electric road vehicles.

This report is applicable to the instrumentation of electric road vehicles, excluding those items which are used as instrumentation in vehicles with internal combustion engines.

- IEC 60785: Rotating machines for electric road vehicles.

This report is applicable to rotating electrical machines [traction motors and auxiliary motors] of electric road vehicles including hybrids, which are fed from the main traction batteries).

- IEC 60786: Controllers for electric road vehicles.

This report is applicable to the equipment on electric vehicles that control the rate of energy transfer between the traction battery or batteries and the motor or motors).

50.04.2 Accumulator (storage battery)

The accumulator is defined as any equipment used for the intermediate storage of electrical energy supplied by the charging unit. Any on-board accumulator is considered as an integral part of the vehicle's accumulator.

The type, dimensions and weight of accumulator/s cannot be changed between official practices and race.

All on-board electrical equipment, unless consisting of items originally powered by dry batteries, small accumulators or their own solar cells, must receive its energy supply from the vehicle's official accumulators.

IMPORTANT: As a condition of entry, a Material Data Safety Sheet must be supplied with the race entry for the machine, including all relevant details as to the accumulator chemistry, human and environmental hazards, handling and specific fire risks and precautions.

50.04.3 Energy recovery

Recovering energy generated by the kinetic energy of the vehicle is permitted.

50.04.4 Use of outside energy sources

The use of any carbon based source of energy in any form whatsoever with the aim of improving the performance of the vehicle is strictly prohibited. This includes the energy used to drive the vehicle's cooling system.

50.04.5 Propulsion system failure

The vehicle must be able to freewheel in the event that the propulsion system has stopped (i.e. fuel/charge exhausted or system failure).

50.04.6 Electrical safety

In no part of the vehicle's electrical equipment may there be voltages of more than 500 volt referred to chassis and system ground respectively (system ground is the ground of the electrical equipment). Between system ground and chassis or body of the vehicle no more than 50 volts are allowed.

The voltage is limited to 500 volt between any two points. In cases where the voltage of the power circuit exceeds 42 volt, this power circuit must be separated from the onboard circuit by an appropriate insulator.

Symbols warning of 'HIGH VOLTAGE' must be displayed on or near the electrical equipment protective covers; all symbols must comprise a black flash of lightning inside a yellow triangle with a black border. The sides of the triangle must measure at least 12 cm, but may be larger if practical.

The power circuit consists of all those parts of the electrical equipment which are used to propel the motorcycle. The on-board circuit consists of all those parts of the electrical equipment which are used for signaling, lighting or communication.

All parts of the electrical equipment must be protected to at least the equivalent of IP 44 type protection (dust proof and splash proof).

50.04.7 General circuit breaker – 'Emergency Stop'

Two emergency stop switches (circuit breakers) are required as a stop has to be easily accessible both to the rider and to marshals.

When seated in a normal riding position, the rider must be capable of interrupting all electrical transmission between the accumulators and the energy consumers by means of a spark-proof general circuit breaker situated in front of him. This breaker must be located in such a way that it can be also operated from outside the vehicle. This breaker must be clearly identified as such.

The use of a lanyard attached to the rider to operate this breaker as an alternative to a button is permitted.

The general circuit must also include a second general circuit breaker which shall be located behind the rider, positioned and easily recognised taking into account that the vehicle may be on one side following an incident. This circuit breaker must be operated by a red button and identified with a yellow disc (minimum 8 cm in diameter) reading 'Emergency' in red or black letters.

The options suggested below are acceptable, as are other solutions that meet the stated requirements. Teams will be required to demonstrate the operation of the Emergency Stops during technical inspection.

1. A low voltage switch (e.g. push button) as a control for a contactor relay in which the contactor can be mounted down near the motor and keep the power voltages and currents away from the rider and top side of the vehicle.
2. A relay with an integrated "breaker" switch, which requires running the full battery voltage to wherever this breaker is mounted.

Operation of the general circuit breaker must also isolate any pre-charge resistors, if installed.

In order to prevent contact melting of the general circuit breaker its ampere square seconds characteristics, representing heat energy dissipated on the breaker contacts during switching, must be sufficient to guarantee proper operation of the circuit breaker, even under surge current conditions, in particular those occurring during the connection of the accumulator to the power plug.

Low power accumulators provided for low voltage circuits, e.g. auxiliary circuits, do not have to be isolated by the general circuit breaker (Emergency Stop) provided that they are completely isolated from the main power accumulators.

50.04.8 Power Indicator

When the vehicle is in a powered on state, there must be two clearly visible indicators, one light on the instrument panel and one light on the rear of the vehicle.

The rear light must be red and visible from at least 10m away, from the side or rear, and must flash between 1 – 2 times / second on a 50% duty cycle.

50.04.9 Fuses (over-current trip switches)

An over-current trip is a device which automatically interrupts the electrical current in which it is installed if the level of this current exceeds a defined limit value for a specific period of time.

Fuses and circuit breakers (but never the motor circuit breaker) count as over current trips. Extra fast electronic circuit fuses and fast fuses are appropriate. The fuses must be in an easily accessible location and as close as possible to the accumulator at both polarities.

All electrical cables inside the motorcycle must be protected by means of over currents trips rated according to the diameter of the individual conductors. Over-current trips must under no circumstances replace the general circuit breaker (Emergency Stop Button).

50.04.10 General electric safety

It must be ensured that the components used cannot cause injury under any circumstances, either during normal operation or in foreseeable cases of malfunction. It must be ensured that the components used for protecting persons or objects can reliably fulfill their function for an appropriate length of time.

50.04.11 Insulation resistance

Every part of the electrical equipment must have a minimum insulation resistance between all live components and earth.

For equipment with up to 300 volts to earth, the insulation resistance must reach the following value: 250 k Ohms.

For equipment with more than 300 volts to earth, the insulation resistance must reach the following value: 500 k Ohms.

The measurement of the insulation resistance must be carried out using a dc Voltage of at least 100 volts.

50.04.12 Dielectric strength

All electrical equipment of the vehicle conducting electric must fulfil the following conditions:

With regard to the dielectric strength, a distinction must be made between materials with light, normal or reinforced insulation.

Normal insulation is insulation which can withstand a test voltage of at least 2000 volts at 50 hertz for a period of one minute. It must only be used for electrical circuits with a nominal voltage not exceeding 500 volts.

Light insulation must not be used (except for the on-board circuit).

All electric live parts must be protected against accidental contact. Insulating material not having sufficient mechanical resistance, i.e. paint coating, enamel, oxides, fibre coatings (soaked or not) or insulating tapes are not accepted.

All electric conducting non live parts must be connected with the motorcycle ground.

50.04.13 Capacitors

Voltage across capacitors belonging to the power circuit should fall below 65 volts within 5 seconds after the general circuit breaker is opened or the over current trips of the accumulator are blown.

50.04.14 Accumulator fastening

The accumulator must be installed securely inside the vehicle and be protected against short-circuits and leakage. The accumulator must be attached to the frame or chassis using metal clamps with an insulating covering.

The fixing method must be designed in such a way that neither the accumulator nor the fastening device itself nor its anchorage points can come loose, even when subjected to a crash. A solid partitioning bulkhead must separate the location of the accumulator from the rider. Each accumulator box must include an air intake with its exit.

The accumulator installation must ensure that in the event of accumulator cell leakage or explosion, the contents are kept away from the rider and do not interfere in any way with the rider's vision or the safe handling of the machine.

50.04.15 Power control

A 'self-closing' throttle (power control) must be applied.

01.53 SPECIFICATIONS FOR SIDECARS (for Sidecars in Track Racing, please refer to the same article in the same section)

53.02

The drive shall be transmitted to the ground only through the rear wheel of the motorcycle.

53.06

Handlebars must be firmly secured to the forks. They must be at a height above the mid point in the seat.

A steering head must be fitted which like the handlebar must not be attached to the unsprung part of the front wheel suspension.

53.07

To reduce the torque in the steering it is allowed to displace the front wheel and the rear wheel leaving a maximum width of 75 mm between them.

53.08

The fuel tank must be sufficiently and independently protected from the ground.

53.09

Articulated Sidecars are strictly forbidden.

53.10

The Sidecar must be fixed to the motorcycle in at least three points, if it is not an integral part of the chassis.

The fixing points must not allow movement at the joints. If the angle of the inclination is changeable, it must be locked in such a way that it is completely secured and not only clamped on.

53.13

A structure of crossed belts or a metallic grid must be fitted to fill the opening between the wheels and the sidecar, to prevent the riders' foot from accidentally touching the ground.

53.14

The minimum dimensions of a Sidecar available for passenger accommodation are:

Length:	1000 mm
Width:	400 mm

Height of the screen protecting the passenger: 300 mm minimum (see diagram N).

53.15

The ground clearance of a machine measured when the machine is loaded must not be less than 175 mm.

53.16

For Sidecars, the rear wheel and the Sidecar wheel must be covered or protected with a solid material.

53.20

The distance between the tracks left by the centre lines of the rear motorcycle wheel and the Sidecar wheel must be at least: 800 mm and not more than 1150 mm.

53.21

On the opposite side of the Sidecar, the exhaust pipe must not extend more than 330 mm from the centre of the machine. On the other side, the exhaust pipe must not extend beyond the width of the Sidecar (see diagram N). The furthest extremity of the exhaust pipe must not exceed the vertical line drawn at a tangent to the rear edge of the rear motorcycle tyre or the rear edge of the Sidecar platform whichever is shorter.

01.55 NUMBER PLATES

For specific details, refer to this article of each discipline (CMS, CTR, **CEN**, CCP).

01.63 FUEL, OIL AND COOLANTS

All motorcycles must be fuelled with unleaded petrol, as this term is generally understood (with the exception of Track Racing, four stroke - single cylinder engines).

63.01 Physical properties for unleaded fuel

63.01.1 Unleaded petrol must comply with the FIM specification.

63.01.2 Unleaded petrol (incl. E10) will comply with the FIM specification if:

(a) It has the following characteristics :

Property	Units	Min.	Max.	Test Method
RON		95.0	102.0	EN ISO 5164
MON		85.0	90.0	EN ISO 5163
Oxygen	% (m/m)		4.0	EN 13132 or 14517
Nitrogen	% (m/m)		0.2	ASTM D 4629
Benzene	% (V/V)		1.0	EN 238 or EN 14517
Vapour pressure (DVPE)	kPa		95.0	EN 13016-1
Lead	g/L		0.005	EN 237 or ICP-OES
Manganese	g/L		0.005	ICP-OES
Density at 15°C	kg/m ³	720.0	775.0	EN ISO 12185
Oxidation stability	minutes	360		EN ISO 7536
Existent gum	mg/100 mL		5.0	EN ISO 6246
Sulphur	mg/kg		10.0	EN ISO 20846 or 20884
Copper corrosion	rating		class 1	EN ISO 2160
Distillation :				
E at 70°C	% (V/V)	22.0	50.0	EN ISO 3405
E at 100°C	% (V/V)	46.0	71.0	EN ISO 3405
E at 150°C	% (V/V)	75.0		EN ISO 3405
Final Boiling Point	°C		210	EN ISO 3405
Residue	% (V/V)		2.0	EN ISO 3405
Appearance	Clear and bright			Visual inspection
Ethanol (1)	% (V/V)		10	EN 13132 or 14517
Olefins	% (V/V)		18.0	EN 14517 or 15553
Aromatics	% (V/V)		35.0	EN 14517 or 15553
Total diolefins	% (m/m)		1.0	GCMS/HPLC

(1) Shall conform to EN 15376

(b) The total of individual hydrocarbon components present at concentrations of less than 5% m/m must constitute at least 30% m/m of the fuel. The test method will be gas chromatography and/or GC/MS.

- (c) The total concentration of naphthenes, olefins and aromatics classified by carbon number must not exceed the values given in the following table :

%	C4	C5	C6	C7	C8	C9+
Naphthenes	0	5	10	10	10	10
Olefins	5	20	20	15	10	10
Aromatics	-	-	1.2	35	35	30

The total concentration of bicyclic naphthenes and bicyclic olefins may not be higher than 1% (m/m). The test method used will be gas chromatography.

- (d) Only the following oxygenates are permitted :

Methanol. Ethanol. Iso-propyl alcohol. Iso-butyl alcohol. Methyl tertiary butyl ether. Ethyl tertiary butyl ether. Tertiary amyl methyl ether. Di-isopropyl ether. N-propyl alcohol. Tertiary-butyl alcohol. N-butyl alcohol. Secondary-butyl alcohol.

- (e) Manganese is not permitted in concentrations above 0.005 g/l. For the present this is solely to cover possible minor contamination by other fuels. The fuel will contain no substance that is capable of an exothermic reaction in the absence of external oxygen.

Lead replacement petrols, although basically free of lead, are not an alternative to the use of unleaded petrol. Such petrols may contain unacceptable additives not consistent with the FIM Fuel Regulations.

63.01.3 Ethanol E85 will comply with the FIM specification if:

(b) It has the following characteristics :

Property	Units	Min.	Max.	Test Method
RON		95.0	110	EN ISO 5164
MON		85.0	100	EN ISO 5163
Vapour pressure (DVPE)	kPa	35.0	95.0	EN 13016-1
Lead	g/L		0.001	ICP-OES
Manganese	g/L		0.001	ICP-OES
Oxidation stability	Minutes	360		EN ISO 7536
Existent gum	mg/100 mL		5.0	EN ISO 6246
Sulphur	mg/kg		10.0	EN ISO 20846 or 20884
Copper corrosion	Rating		Class 1	EN ISO 2160
Distillation :				
Final Boiling Point	°C		210	EN ISO 3405
Residue	% (V/V)		2	EN ISO 3405
Appearance	Clear and bright			Visual inspection
Ethanol + higher alcohols	% (V/V)	75		EN 13132 or 14517
Higher alcohols (C3-C8)	% (V/V)		2.0	EN 13132 or 14517
Methanol	% (V/V)		1.0	EN 13132 or 14517
Ethers (5 or more C atoms)	% (V/V)		5.2	EN 13132 or 14517
Unleaded petrol as specified in 2.10.1.2	% (V/V)	14	25	
Water	% (V/V)		0.3	EN 12937
Inorganic chloride	mg/L		1	EN 15484
Acidity (as acetic acid)	% (m/m) (mg/L)		0.005 (40)	EN 15491

63.02 Oil

For oil used in two stroke mixtures, the following tolerances on the fuel specifications will be allowed:

• Density at 15°C	Plus/minus 30 kg/m ³
• Distillation residue	Not controlled

Any infringement of the fuel specifications will automatically result in the exclusion of the competitor from the entire meeting (see also Sporting Code Art. 140.1). The result of the competitors' fuel sample analysis (A or B Sample) more favourable to the competitor will be taken into account (See also Art. 63.05.3).

If the fuel available locally for the event is not of a sufficient quality for use by competitors, the FMN of the organising country must ask the FIM for a waiver in order to enable the use of fuel not corresponding to the characteristics defined above.

63.03 Air

Only ambient air may be mixed with the fuel as an oxidant.

63.04 Primary Tests

63.04.1 In all FIM Championship and Prizes, the FIM may require tests of fuels to be administered before, or at the time of delivery to, an event at which such fuels are to be used.

63.04.2 FIM may request any person or organisation, being a potential supplier of fuel, to submit a sample for testing for conformity with the fuel specifications in Art. 63.01.

63.05 Fuel Test Procedures

63.05.1 Fuel tests may be administered at any time and place during the course of any event under the authority of the FIM.

63.05.2 The CTI Bureau, in consultation with the relevant Commission President, has sole authority to, and may, direct the administration of fuel tests during the course of an FIM Championship or Prize Event. Such direction must be by written document (Fuel Test Order) which must be delivered to the Jury President (**or the Race Direction where applicable**) before the meeting. The Jury President (**or the Race Direction where applicable**) must deliver the Fuel Test Order to the Chief Technical Steward for the meeting who is responsible for the administration of the fuel tests.

The Fuel Test Order must nominate :

- (a) The criteria (which may be random) for selection of the machines from which samples are to be taken; and
- (b) The officials who must administer the tests.
- (c) At least 3 of the characteristics specified in Arts. 63.01 and 63.02 to be the subject of the tests, or only 1 characteristic when using an ASTM approved “short test” or “field test method” for the detection of only one of the characteristics in a fuel sample.

63.05.3 Fuel tests must be administered according to the Fuel Test Order and must comply with the following procedures :

- (a) Only nominated officials may take samples.
- (b) Containers for holding samples :
 - (i) must be clean and constructed of robust, fuel non reactive, impermeable material.
 - (ii) must be sealable;
 - (iii) must have provision for identification.
- (c) Equipment used for the extraction of fuel from machines must be clean and constructed of fuel non-reactive material.
- (d) The FMNRs must ensure that there is a supply of at least 12 containers (12X 1 litre each).
- (e) Each sample must be divided into two and placed in separate containers, (2 samples of maximum 1 litre each). Each sample may be initially tested for one of the characteristics, using an ASTM approved field test method. The results obtained from such a test must be given immediately to the International Jury. The containers must be immediately sealed and identified by reference to the machine from which the sample was taken.

This information must be entered on a certificate (FIM Fuel Sample Certificate) which must certify the date, place and time of taking the sample, the identity of the machine from which the sample was taken, and the identity of its rider.

- (f) Both samples (sample A and sample B) must remain in the control of the Technical Steward. The rider or the representative of the rider/ team must sign the FIM Fuel Sample Certificate acknowledging that a sample was taken, and must be given a copy of the Certificate.
- (g) At the end of the meeting the Technical Steward must deliver both samples (sample A and sample B) to a courier authorised by the FIM, Jury President or the Technical Steward. The Technical Steward must return a copy of the Fuel Sample Certificate, signed by the courier, to the Jury President.
- (h) The authorised courier must deliver both samples (sample A and sample B), together with copies of the relevant Fuel Sample Certificates, to an FIM authorised laboratory, where they must be tested for content in accordance with standard scientific procedures.
- (i) The results obtained from such testing must be attached to the laboratory's copy of the Fuel Sample Certificate and delivered to the FIM as soon as practicable after the results have been obtained.
- (j) In case of non conformity to the rules, the FIM must as soon as practicable after receipt of the results notify :
 - (i) the relevant riders or team representatives ;
 - (ii) the relevant FMNR ;
 - (iii) the Jury President for the relevant meeting.

63.05.4 The FIM may authorise one or more named laboratories for testing fuels. Such authorisation must be by written document, distributed to all FMNRs.

63.05.5 A Jury may direct the administration of fuel tests during the course of any international event other than an FIM Championship or Prize Event. Such direction must be by Fuel Test Order which must be delivered to the Technical Steward. Such Fuel Test Order has the same authority as if it had been issued by the CTI Bureau under Art. 63.05.2. The procedures for the administration of fuel tests under this Article must comply with the procedures under Arts. 63.05.2 and 63.05.3.

63.05.6 For tests under Art. 63.04 all characteristics specified in Art. 63.01 must be present for the tested fuel to comply.

63.05.7 For tests under Arts. 63.05.2 and 63.05.5 tested fuel must comply with the characteristics specified in the relevant Fuel Test Order.

63.06 Fuel Test Costs

63.06.1 The costs of fuel tests conducted under Arts. 63.04.1, 63.04.2 and 63.05.2 will be paid by the FIM.

63.06.2 The costs of fuel tests conducted under Art. 63.05.5. will be paid by the organiser of the event.

63.06.3 Where a fuel test is ordered by a Jury in relation to a protest, the party which loses the protest must bear the entire cost of the fuel test, or such proportion thereof as is directed by the Jury.

01.65 EQUIPMENT AND PROTECTIVE CLOTHING

During practising and racing, riders and passengers must wear the protective clothing and footwear

For specific details, refer to this article of each discipline (CMS, CTR, **CEN**, CCP).

65.07 Material equivalent to leather

The following characteristics of the material must be at least equivalent to 1.5mm of cowhide (not split leather):

65.07.1 Fire retardant quality

65.07.2 Resistance to abrasion

65.07.3 Coefficient of friction against all types of asphalt

65.07.4 Perspiration absorbing qualities

65.07.5 Medical test - non toxic and non-allergenic

65.07.6 Fabric of a quality that does not melt.

65.07.7 Clothing in material other than leather must bear a sticker or label which says "in conformity with the FIM rules". This label must be sewn or attached to the clothing in a permanent way.

65.08 Approval

The clothing manufacturer is responsible for ensuring that the products and materials that carry his name conform to these rules. The FIM cannot be held liable for any injuries that a rider or passenger may sustain from their use.

01.67 WEARING OF HELMETS

It is compulsory for all participants taking part in practice and races to wear a protective helmet. The helmet must be properly fastened, be of a good fit, and be in good condition. The helmet must have a chin strap type 'retention system'.

Helmets constructed with an outer shell of more than one piece are permitted, provided that, in case of emergency; they can be quickly and easily removed from the rider's head by releasing or cutting the chin strap only.

All helmets must be marked with one of the official international standard marks mentioned in Art. 01.70 or the Approval Mark (stamp) of the FMN of the rider. Helmets marked by an FMN must comply with one of the International Standards listed in Art. 01.70 before approval by an FMN.

Failure to observe the above rules will entail exclusion.

01.69 HELMET OPERATIVE INSTRUCTIONS

69.01

Scrutineers, under the supervision of the Chief Technical Steward, may check prior to practice and the races that all helmets meet the technical requirements.

69.02

If a helmet does not meet the technical requirements and is found to be defective, the Technical Steward must remove all approval marks and retain the helmet until the end of the event. The rider must submit another helmet for approval by the Technical Steward. After an accident involving impact, the helmet must be presented to the Technical Steward for examination (see also Art. 77.02.14).

69.03

All helmets must be intact and no alteration must have been made to their construction. After an accident involving impact the helmet must be presented to the Technical Steward for examination.

69.04

The Technical Steward and/or the Technical Scrutineer may perform the following checks before the rider is permitted to take part in practice of the race:

69.04.1 That the helmet fits well on the rider's head,

69.04.2 That it is not possible to slip the retention system over the chin, when fully fastened,

69.04.3 That it is not possible to pull the helmet over the rider's head by pulling it from the back of the helmet.

01.70 RECOGNISED INTERNATIONAL HELMET APPROVAL MARKS

- Europe ECE 22-05 'P', 'NP' or 'J'
- Japan JIS T 8133 : 2000 (**accepted until 31.12.2011**)
JIS T 8133 : 2007 (from 01.01.2010)
- USA SNELL M 2005 (**accepted until 31.12.2011**)
SNELL M 2010 (from 01.01.2010)

(see also the International Helmet Standards in diagram section)

01.71 EYE PROTECTION

The use of glasses, protective goggles as well as helmet visors and 'tear off's' is permitted. The material used for eye protectors and glasses must be made of shatter-proof material. Helmet visors must not be an integral part of the helmet.

Eye protectors which cause visual disturbance (scratched etc.) must not be used.

01.73 NATIONAL COLOURS FOR HELMETS (with the exception for the CCP)

The following National colours are approved:

Andorra	FMA	White with vertical blue, yellow and red bands
Argentina	CAMOD	White with blue horizontal band
Australia	MA	Green and yellow sides, red, white & blue representation of the Australian flag across the top
Austria	OeAMTC	Bright red with a 60 mm wide black band and the label of the OeAMTC in a white field on the front side
Belgium	FMB	Yellow
Brazil	CBM	Yellow and green
Bulgaria	BMF	Green and red
Canada	CMA	White and 3 Red Maple leaves, one on front and one on each side
Chile	FMC	Red with blue band and yellow stars
China	CMSA	Red and yellow
Czech Republic	ACCR	Blue with red, white and blue border
Denmark	DMU	Red and white
Finland	SML	White with blue cross
France	FFM	Blue
Germany	DMSB	White with black border
Great Britain	ACU	Green
Greece	ELPA	White with blue border
Hungary	MAMS	Red and green
Ireland	MCUI	Green and orange
Italy	FMI	Red with one green and one white horizontal band
Japan	MFJ	White with red circle on top
Kenya	KMSF	Black, Red, Green, with white bands and the country name KENYA on both sides.
Luxembourg	MUL	Purple
Mexico	FMM	White with green and red border
Monaco	MCM	Blue and white
Netherlands	KNMV	Orange

New Zealand	MNZ	White with black kiwi on front
Norway	NMF	Red and blue
Peru	FPEM	Red with 75 mm wide white strips and blue and yellow chequered border
Poland	PZM	White with red band
Portugal	FNM	White
Rumania	FRM	Black with vertical blue, yellow and red bands with national emblem.
Russia	MFR	White with a red border and a vertical red band with star
San Marino	FSM	White with the San Marino National emblem
Slovakia	SMF	Blue, red and white
South Africa	MSA	Black, green, blue and red with yellow and white bands
Spain	RFME	Yellow and red
Sweden	SVEMO	Blue and yellow
Switzerland	FMS	Red with white cross
Uruguay	FUM	Light blue
USA	AMA	Blue with 2 white bands

In addition to this, for the holders of World or National championships, a central band 50 mm wide from front to back across the top carrying the national colours or a rainbow is admitted.

In competitions between national teams, helmets must be the same colour for each team member and must include in the overall helmet colour scheme, their national flag colours, presented in stripes, bands or other design.

01.75 BADGE OF THE FIM

Under certain circumstances the FIM may permit the use of the FIM badge on certain equipment in order to show that the latter conforms with the standards laid down by the FIM. When this authorisation is granted and provided the equipment on which it appears is in good condition, the badge is then the guarantee of the conformity with the standard set by the FIM.

01.76 NUMBER SASHES (BIBS)

For specific details, refer to this article of each discipline (CMS, CTR, **CEN**, CCP).

01.77 CONTROL**77.01 Verification****General**

A rider is at all times responsible for his machine.

77.01.1 The Chief Technical Steward must be in attendance at an event 1 hour before technical verifications are due to begin. He must inform the Clerk of the Course, Jury President and CTI Delegate, if present, of his arrival.

77.01.2 He must ensure that all technical stewards, appointed for the event, carry out their duties in a proper manner.

77.01.3 He shall appoint the technical stewards to individual posts for the race, practices and final control.

77.01.4 Technical inspections will only be carried out when the technical specification form of the motorcycle has been presented by the Organiser.

77.01.5 The rider, or his mechanic, must be present with the machine for technical control within the time limits stated in the Supplementary Regulations. On request of the Technical Steward, the riders must present themselves to the technical verification.

77.01.6 The Chief Technical Steward must inform the Clerk of the Course/ Jury President of the results of the technical control. The Chief Technical Steward will then draw up a list of accepted machines and submit this list to the Clerk of the Course.

77.01.7 The Chief Technical Steward has the right to look/ inspect any part of the motorcycle at any time of the event.

77.02

Any rider failing to report as required below may be excluded from the meeting. The Clerk of the Course may forbid any person who does not comply or any rider who can be a danger to other participants or to spectators, to take part in the practising or in the races.

77.02.1 The technical control must be carried out in accordance with the procedure and times fixed in the Disciplines' Rules and the Supplementary Regulations of the event. The maximum number of persons permitted to be present at the technical verification is the rider, plus two others. For Team events, the Team Manager is also allowed.

77.05 Dangerous machines

If, during practice or the race, a Technical Steward finds that a machine is defective and might constitute a danger to other riders, he must immediately notify the Clerk of the Course or his deputy. It is their duty to exclude such a machine from either the practice or from the race itself.

01.79 SOUND CONTROL

79.01 The '2 metre max' method – The new test method to verify the sound levels (not applicable to Trial motorcycles)

In order to pursue the measures taken to reduce the sound level in favour of environment and in the framework of the 'RIDE QUIET' campaign, a new method for measuring the sound level called '2 metre max' will progressively be applied as from 2010 in all 'all-terrain' disciplines (and more specifically in Motocross, Enduro and Track Racing).

WHAT DOES IT CONSIST OF?

The 2 metre max method shows a very good correlation between the sound power level (LwA) issued by motorcycles in full acceleration, and the maximum sound pressure levels measured at proximity of the same motorcycles, with engines **at idle** and quickly taken to their maximum rotational speeds.

The technical specifications and the resources to initiate the application of this new method, for the use of the technical stewards and officials are mentioned in Art. 79.01 of these Technical Regulations. This article will detail the "2 metre max" method, the sound levels, the indispensable tools, but also the tolerances applied.

Only the sound levels measured with the '2 meter max' method will be considered by the technical stewards and the jury of the event to decide whether the motorcycle is in conformity with the maximum sound levels authorised.

THE 2 METER MAX METHOD - IN FOCUS

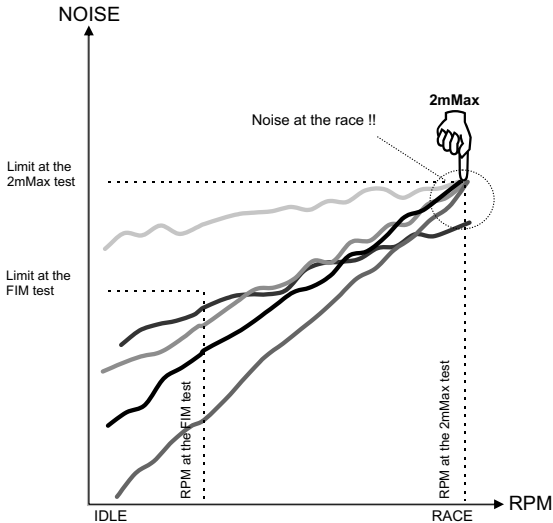

THE OPERATING PROCEDURE

The '2 metre max' method will consist in quantifying not only the sound level produced by the silencer of the exhaust, but also the maximum global sound level achieved by the motorcycle when the engine rpm's are raised to the maximum engine speed, limited by

- ⇒ natural regulation for 2T, or
- ⇒ rev limiter for 4T.

For 250cc and 500cc (4 stroke) engines used in Speedway, Long track and Ice Racing, without rev limiter, it would be advisable to limit the full open the throttle for 1 or 2 seconds maximum.

THE PREPARATION OF THE SOUND METER

- Calibrate the sound meter at 93,5 dB or 113.5 dB to take into account the incidence of the wind foam ball
- Position the wind foam ball on the microphone
- Activate the 'A' weighing
- **FAST** time weighting must be activated
- Select range Hi **80~130 dB**
- Activate the function MAX MIN – set on **MAX**

THE SET UP OF THE SOUND METER AND THE MOTORCYCLE

- The sound levels will be measured with the sound meter/microphone fixed on a tripod, in the horizontal position, at the rear of the motorcycle.
- **For the place and position of the motorcycle, ensure that there are no solid obstacles within 10 meters around the microphone.**
- **The sound meter will be positioned at a distance of 2 metre behind the motorcycle, with an angle of 45° away from the centerline, on the exhaust side and at a height of 1.35 metre above the ground, with the sound meter level.**
- **The 2 metre distance is measured from the point where the centre of rear tyre touches the ground.**
- It is preferred to make the tests on soft ground, not reverberating, i.e. grass or fine gravel.
- **In other than moderate wind, machines should face forward in the wind direction.**
- The ambient sound level must remain lower than 100 dB/A.

THE POSITIONING OF THE MOTORCYCLE (see illustrations following)

The reference points:

- For a motorcycle: the contact point of the rear wheel on the ground.
- For motorcycles fitted with 2 exhaust outputs, the measurement will be made on the side of the air intake. If a central positioned air intake is used, both sides will be tested.
- For Side-cars: the contact point of the side wheel on the ground.
- For Quad vehicles: the vertical line to the ground from the centre point of the rear axle.

- For Quad vehicles with exhaust outlet moved from the median axis, the measurement will be made on the offset side.

To make repetitive measurements, all motorcycles can be positioned into a small frame fixed on the ground.

THE NEW 2 METRE MAX METHOD

– THE OPERATION – PROTECT YOUR HEARING – USE EAR PROTECTION

- The measurement is made with motorcycle on its wheels, with a hot engine.
- The technical steward takes place besides the motorcycles, opposite to the microphone, or in front of the handlebars near the front wheel, not to screen or stand between the bike and the microphone.
- If a second steward is permanently attending the sound level checks, it is strongly advised for him to use earplugs, **a headset or ear protectors**.
- The Inspector shall open throttle as fast as possible **until full open throttle (instantly, within 0.3 seconds). He will keep at max engine 'rpm' for at least 1 second. To end, the inspector will release the throttle quickly.**
- **If the result exceeds the limit, including 'after fire', the Inspector shall test the motorcycle, maximum 2 times more.**
- **For motorcycles equipped with an engine rpm limiter, opening the throttle will be made - instantly, within 0.3 seconds - and kept open until at least 1 second has evolved and/or when there is an audible sign of over revving the engine.**
- **For motorcycles without an engine 'rpm' limiter, the opening of the throttle will have to be lower than 2 seconds and/or when there is an audible sign of over-revving the engine.**
- If the engine tends to suffocate, close the throttle slightly and re-open the throttle.
- If detonations appear, the measurement must be started again.

The numbers obtained from the test shall not be rounded down.

For the sound level measurement, the handling of the throttle is limited only to the Inspector, who shall open the throttle himself in order to minimize the influence by another operator (for that, it is helpful to have the microphone equipped with an extension cable to the sound meter).

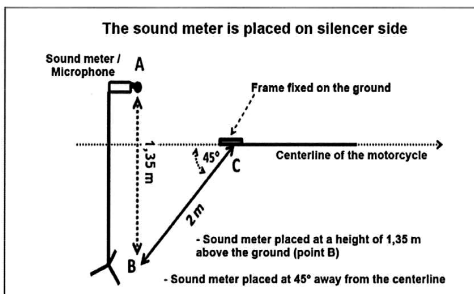
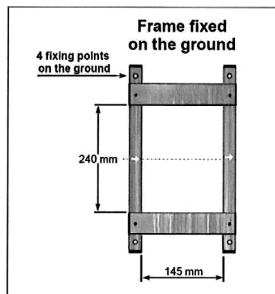

POSITION OF THE SOUND METER IN RELATION TO THE MOTORCYCLE

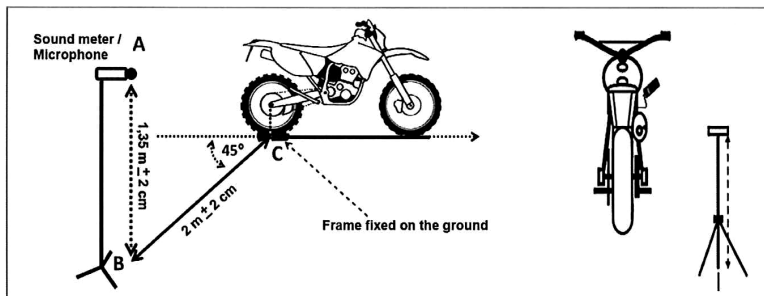

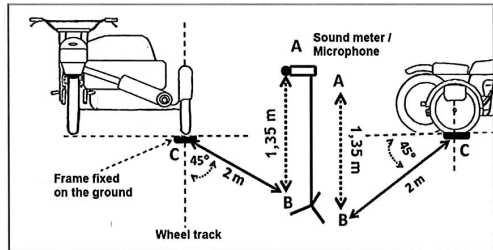
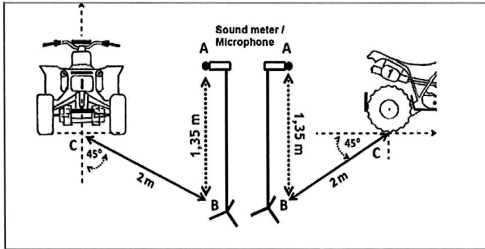

THE IMAGE OF THE SOUND MEASUREMENT PROCEDURE

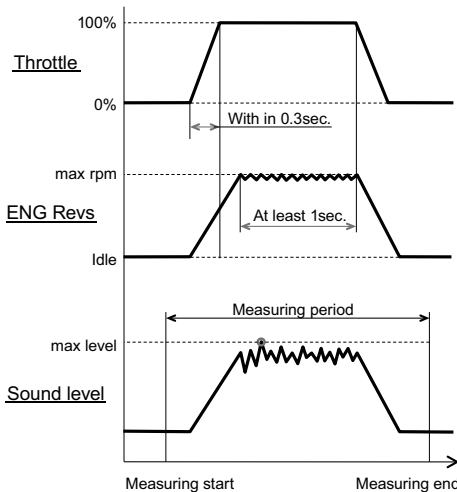

1. The Inspector shall open the throttle until full open throttle within 0.3 seconds.

2. And keep at the max rpm (at rpm limiter) at least 1 second. Then, release the throttle quickly.

3. The sound level is measured in the all period and the maximum level shall be recorded in any case. (automatically by the sound meter).

Time

THE MEASUREMENT – RECORDING OF THE SOUND LEVEL

- When the measurement is considered acceptable, write down the result, then reset (push on the sideline) the MAX MIN setting until the disappearance of the previously displayed value.
- Push again on the sideline MAX MIN to arm the sound level meter.
- The sound level meter is then ready for the following measurement.

An attempt by a participant to prevent his/her engine to reach the maximum published rpm figure will be considered a breach of the rules.

Even after passing the sound control, if there is doubt, the motorcycle may be checked again.

A noticeably lower engine speed is detected easily by hearing. If doubt, control of the value of the rpm limiter with a tachometer.

Sound levels will be controlled to limits as stated in **each section of the relevant discipline (CMS, CEN, CCP).**

For the initial sound control and technical inspection, a rider (or his mechanic) shall present only one spare silencer per machine.

Other spare silencers may be presented after all participants have presented their motorcycles, or on the following days of the event.

79.02 The ‘static’ method (see Motocross and Trial sections)

79.03 Sound control during and after the competition

In a competition which requires a final examination of machines before the results are announced, this examination must include a sound control measurement of at least three machines chosen at the discretion of the Clerk of the Course in co-operation with the Chief Technical Steward. Refer to each discipline for more info.

01.80 GUIDELINES FOR USE OF SOUND LEVEL METERS

80.01

The Sound Control Officer (NCO) must arrive in sufficient time for discussions with the Clerk of the Course and other Technical Officials in order that a suitable test site and testing policy can be agreed.

80.02

Sound level measuring equipment must include a compatible calibrator, which must be used immediately before testing begins and always just prior to a re-test if a disciplinary sanction may be imposed.

Two sets of equipment must be available in case of failure of tachometer, sound level meter or calibrator during technical control.

80.03

Before testing, the NCO should if possible liaise with a maximum of two holders of FIM Entrant's or Manufacturer's licences, or team managers, who have sound test equipment including calibrators, in order to agree the accuracy of the official sound level meter.

80.09 Corrections

Class 1 (Type 1) sound meter: deduct 1 dB/A

Class 2 (Type 2) meter: deduct 2 dB/A

80.10 Ambient temperature

No deductions.

80.11 Precision of the method (tolerances)

All **corrections** are cumulative.

Action and decisions will depend on the Sporting Discipline concerned, and decisions taken during prior discussions with the FIM Technical Director and/or the Chief Technical Steward.

01.81 TIMEKEEPING

Since 1.1.1993, the responsibility for Timekeeping has been referred to the each Sporting Commission.

81.01 Timekeeping Instruments

All motorcycles (in CMS, CEN and in CTR and CCP where applicable) must have a correctly positioned transponder support. The transponder must be supplied or approved by the official Timekeeper and fixed to the motorcycle (for off-road models, typically on the front fork), on either the left or right side, avoiding being shielded by carbon pieces.

Correct attachment of the transponder bracket consists of a minimum of tie-wraps, but preferably by screws or rivets. Any transponder retaining clip must also be secured by a tie-wrap. Velcro or adhesives alone will not be accepted.

FIM - SOUND LEVELS AS FROM 2011

DISCIPLINE	Max sound limit	Comments
MOTOCROSS		
Checks before the race	115 dB/A	+ usual precision for the sound meter: Class 1: + 1 db/A Class 2: + 2 dB/A
Checks after the race	116 db/A	+ usual precision for the sound meter: Class 1: + 1 db/A Class 2: + 2 dB/A
ENDURO		
Checks before the race	112 dB/A	+ usual precision for the sound meter: Class 1: + 1 db/A Class 2: + 2 dB/A
Checks after the race	113 db/A	+ usual precision for the sound meter: Class 1: + 1 db/A Class 2: + 2 dB/A
CROSS COUNTRY RALLIES		
Checks before the race	115 dB/A	+ usual precision for the sound meter: Class 1: + 1 db/A Class 2: + 2 dB/A
Checks after the race	116 db/A	+ usual precision for the sound meter: Class 1: + 1 db/A Class 2: + 2 dB/A
TRIAL		
No Change	Following the present system	EC Directives
TRACK RACING		
No Change	following the present system for Homologated Silencers - Max 115 dB/A	
All Disciplines: No rounding down of figures.		

NUMBERS / NUMEROS

0

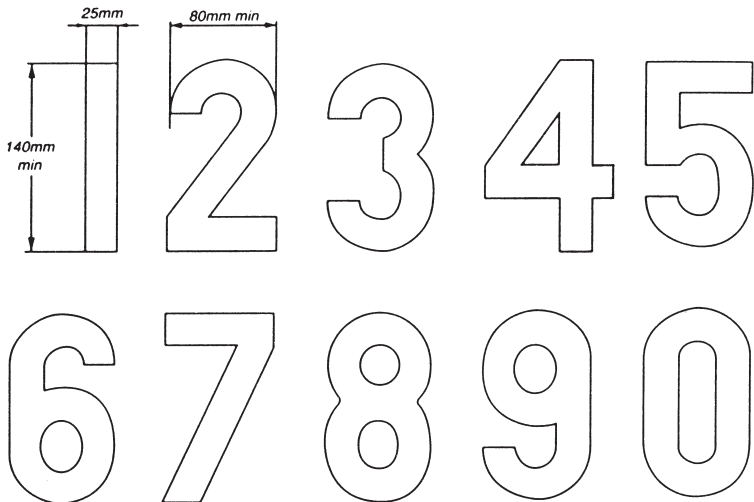
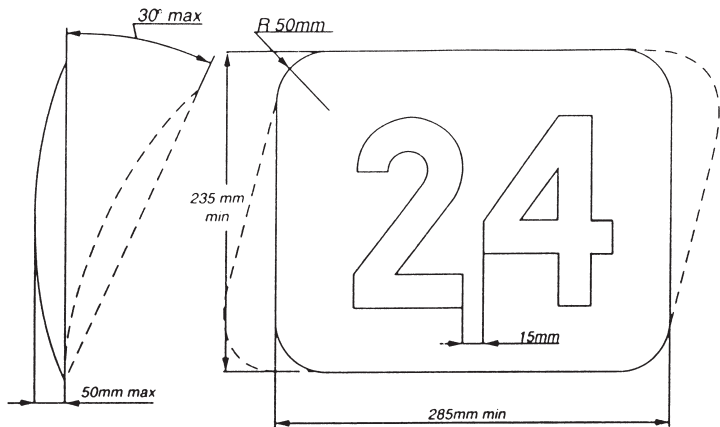

Futura Heavy

0 1 2 3 4 5 6 7 8 9

Futura Heavy Italic

0 1 2 3 4 5 6 7 8 9

Univers Bold

0 1 2 3 4 5 6 7 8 9

Univers Bold Italic

0 1 2 3 4 5 6 7 8 9

Oliver Med.

0 1 2 3 4 5 6 7 8 9

Oliver Med. Italic

0 1 2 3 4 5 6 7 8 9

Franklin Gothic

0 1 2 3 4 5 6 7 8 9

Franklin Gothic Italic

0 1 2 3 4 5 6 7 8 9

TEN FITTING TESTS FOR HELMETS DIX TESTS D'ADAPTATION POUR LES CASQUES

1. *Obtain correct size by measuring the crown of the head*
Avoir la bonne grandeur en mesurant le sommet de la tête
2. *Check there is no side to side movement*
Vérifier qu'il n'y ait pas de déplacement d'un côté à l'autre
3. *Tighten strap securely*
Serrer solidement la jugulaire
4. *With head forward, attempt to pull up back of helmet to ensure helmet cannot be removed this way*
Tête en avant, essayer de soulever le casque pour s'assurer qu'il ne peut pas être enlevé de cette façon

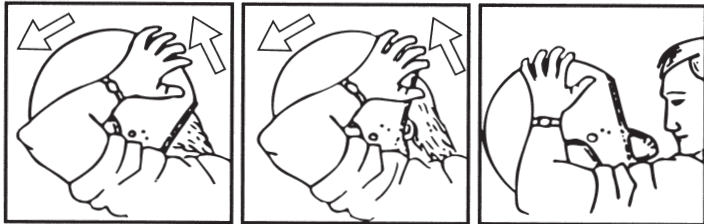

5. *Check ability to see clearly over shoulder*
Vérifier si vous pouvez voir clairement par-dessus l'épaule
6. *Make sure nothing impedes your breathing in the helmet and never cover your nose or mouth*
S'assurer que rien ne gêne votre respiration dans le casque et ne jamais couvrir le nez ou la bouche
7. *Never wind scarf around neck so that air is stopped from entering the helmet. Never wear scarf under the retention strap*
Ne jamais enrouler une écharpe autour du cou, car cela empêche l'air d'entrer dans le casque. Ne jamais porter d'écharpe sous la jugulaire
8. *Ensure that visor can be opened with one gloved hand*
S'assurer que la visière peut être ouverte avec une main gantée
9. *Satisfy yourself that the back of your helmet is designed to protect your neck*
S'assurer que l'arrière de votre casque a une forme telle qu'il vous protège la nuque
10. *Always buy the best you can afford*
Toujours acheter le meilleur que vous pouvez vous offrir

INTERNATIONAL HELMETS STANDARDS

NORMES INTERNATIONALES DES CASQUES

ECE 22 - 05 "P" (EUROPE)

The ECE mark consists of a circle surrounding the letter E followed by the distinguishing number of the country which has granted approval.

E1 for Germany, **E2** for France, **E3** for Italy, **E4** for Netherlands, **E5** for Sweden, **E6** for Belgium, **E7** for Hungary, **E8** for Czeck Republic, **E9** for Spain, **E10** for Yugoslavia, **E11** for UK, **E12** for Austria, **E13** for Luxembourg, **E14** for Switzerland, **E15** (- vacant), **E16** for Norway, **E17** for Finland, **E18** for Denmark, **E19** for Roumania, **E20** for Poland, **E21** for Portugal, **E22** for the Russian Federation, **E23** for Greece, **E24** for Ireland, **E25** for Croatia, **E26** for Slovenia, **E27** for Slovakia, **E28** for Bielo Russia, **E29** for Estonia, **E30** (- vacant), **E31** for Bosnia and Herzegovina, **E32** for Letonie, **E34** for Bulgaria, **E37** for Turkey, **E40** for Macedonia, **E43** for Japan, **E44** (- vacant), **E45** for Australia, **E46** for Ukraine, **E47** for South Africa, **E48** New Zealand.



Below the letter **E**, the **approval** number should always begin with 05. Below the approval number is the serial production number. (Label on retention system or comfort interior).



(JAPAN) JIS T 8133 : 2000 - 2007
(Label affixed inside the helmet).



(USA) SNELL M2005
(Label affixed inside the helmet).



(USA) SNELL M2010
(Label affixed inside the helmet).

For more details consult the F.I.M. Technical Rulebook

Technical Rules
Règlements Techniques

Motocross

(Including Rules for Quads and Snowcross)
(Règlements pour Quads et Motoneige inclus)

TECHNICAL RULES FOR MOTOCROSS (CMS)

Table of contents

01.01	50
01.03	50
01.05	50
01.07	CLASSES.....	50
01.11	MEASUREMENT OF CAPACITY.....	51
01.17	SUPERCHARGING.....	51
01.18	TELEMETRY.....	51
01.19	MOTORCYCLE WEIGHTS.....	52
01.21	DESIGNATION OF MAKE.....	52
01.23	DEFINITION OF A PROTOTYPE.....	52
01.25	GENERAL SPECIFICATIONS.....	52
01.26	DEFINITION OF A FRAME OF A SOLO MOTORCYCLE.....	53
01.27	STARTING DEVICES.....	53
01.29	OPEN TRANSMISSION GUARDS.....	53
01.31	EXHAUST PIPES.....	53
01.33	HANDLEBARS.....	53
01.35	CONTROL LEVERS.....	53
01.37	THROTTLE CONTROLS.....	54
01.39	FOOTRESTS.....	54
01.41	BRAKES.....	54
01.43	MUDGUARDS AND WHEEL PROTECTION.....	54
01.45	STREAMLINING.....	55
01.47	WHEELS, RIMS, TYRES.....	55
01.49	MOTOCROSS TYRES.....	56
01.51	ADDITIONAL SPECIFICATIONS FOR SUPERMOTO.....	56
01.53	ADDITIONAL SPECIFICATIONS FOR SIDECARS.....	57
01.55	NUMBER PLATES.....	57
01.63	FUEL, FUEL/OIL MIXTURES.....	61
01.65	EQUIPMENT AND PROTECTIVE CLOTHING.....	61
01.67	WEARING OF HELMETS.....	62
01.69	HELMET OPERATIVE INSTRUCTIONS.....	62
01.70	RECOGNISED INTERNATIONAL APPROVAL MARKS.....	62
01.71	EYE PROTECTION.....	62
01.73	NATIONAL COLOURS FOR HELMETS.....	62
01.75	BADGE OF THE FIM.....	63
01.76	NUMBER SASHES (BIBS).....	63
01.77	CONTROL.....	64

01.79	SOUND CONTROL.....	65
01.80	GUIDELINES FOR USE OF SOUND LEVEL METERS.....	69
01.81	TIME KEEPING.....	69
01.82	TECHNICAL SPECIFICATIONS FOR SNOWMOBILES	69
01.83	TECHNICAL SPECIFICATIONS FOR QUAD RACERS	72
DIAGRAMS.....		75

01.01 INTRODUCTION

For the main article, refer to the same number in the General section

01.03 FREEDOM OF CONSTRUCTION

For the main article, refer to the same number in the General section

01.05 CATEGORIES AND GROUPS OF MOTORCYCLES

For the main article, refer to the same number in the General section

01.07 CLASSES

Groups are again separated into classes according to cylinder capacities as detailed below. Generally, these classes must be observed for all meetings. (However, see Art. 032.3.2 of the Motocross Rules).

Category I

Group A1 Motorcycles

Class		over (cc)	up to (cc)	
50		-	50	
65		50	65	
85	(2-stroke)	65	85	
	*(4-stroke)	85	150	
100		85	100	
125	(2-stroke)	100	125	
	(MX2) (4-stroke)	175	250	
175		125	175	
250	(2-stroke)	175	250	
	(MX1) (4-stroke)	290	450	
350		250	350	
	(MX3)	(2-stroke)	175	500
		(4-stroke)	290	650
750		500	750	
1000		750	1000	
1300		1000	1300	

Groups B1, B2 Sidcars

Over 350 cc and up to a maximum of 750 cc for 2-stroke engines or a maximum of 1000 cc for 4-stroke mono and bi-cylinder engines.

Category II

Group E Snowmobiles

Class	over (cc)	up to (cc)
250	-	250
350	250	350
500	350	500
750	500	750
1050	750	1050
1300	1050	1300

Group G Quad racers

Four wheeled, two wheel driven balloon tyred off-road vehicles having a wheel at each diagonal extremity, consisting of a complete integral unit having accommodation for a rider only sitting astride, steered by a handlebar. Same classes as Category I, Group A1.

01.11 MEASUREMENT OF CAPACITY

For the main article, refer to the same number in the General section

01.17 SUPERCHARGING

For the main article, refer to the same number in the General section

01.18 TELEMETRY

For the main article, refer to the same number in the General section

01.19 MOTORCYCLE WEIGHTS
Weights of motorcycles without fuel

19.01

The minimum weights are :

for the 65 cc class	Up to 65cc – 2T	53 kg
for the 85 cc SW class (small wheels)	65cc up to 85cc - 2T	63 kg
	100cc up to 150cc - 4T	71 kg
for the 85 cc LW class (large wheels)	65cc up to 85cc - 2T	65 kg
	100cc up to 150cc - 4T	73 kg
for MX1 motorcycles	175cc up to 250cc - 2T	98 kg
	290cc up to 450cc - 4T	102 kg
for MX2 motorcycles	100cc up to 125cc - 2T	88 kg
	175cc up to 250cc - 4T	95 kg
for MX3 motorcycles	290cc up to 500cc - 2T	102 kg
	475cc up to 650cc - 4T	102 kg

A 1 % tolerance in the weight of the machine after the race is accepted.

01.21 DESIGNATION OF MAKE

For the main article, refer to the same number in the General section

01.23 DEFINITION OF A PROTOTYPE

For the main article, refer to the same number in the General section

01.25 GENERAL SPECIFICATIONS

For the main article, refer to the same number in the General section

25.05

For 125 cc, only single cylinder engines are allowed.

01.26 DEFINITION OF A FRAME OF A SOLO MOTORCYCLE

For the main article, refer to the same number in the General section

01.27 STARTING DEVICES

Starting devices are compulsory.

01.29 OPEN TRANSMISSION GUARDS**29.01**

If the primary transmission is exposed, it must be fitted with a guard as a safety measure. The guard must be conceived in such a manner that under no circumstances the rider or the passenger can come into accidental contact with the transmission parts. It must be designed to protect the rider from injuring his fingers.

29.02

A guard must be fitted to the countershaft sprocket.

01.31 EXHAUST PIPES

For the main article, refer to the same number in the General section

Exhaust pipes and silencers must fulfill all the requirements concerning sound control (see also Art. 01.79).

01.33 HANDLEBARS

Handlebars made from carbon-carbon, carbon-kevlar and/or other composite materials are not authorised.

For the main article, refer to the same number in the General section.

01.35 CONTROL LEVERS

For the main article, refer to the same number in the General section.

01.37 THROTTLE CONTROLS

37.02

Snowmobiles and Sidecars must have an ignition cut-out fitted to operate when the rider leaves the machine. This ignition cut-out system must interrupt the primary circuit and must be wired for both the supply and return of the current.

This ignition cut-out must be placed as near to the centre of the handlebar as possible and must be operated by a non-elastic string of adequate length and thickness and for Sidecars strapped to the rider's right-hand wrist. A spiral cable (similar to that of a telephone wire) of maximum 1 m in length is permitted.

For Snowmobiles, it must be attached to the rider's belt.

01.39 FOOTRESTS

39.01

Footrests may be of a folding type but in this case must be fitted with a device which automatically returns them to the normal position, and an integral protection is to be provided at the end of the footrest which must have at least an 8 mm radius (see diagrams E and F).

01.41 BRAKES

For the main article, refer to the same number in the General section

41.04

Snowmobiles must have at least one brake.

01.43 MUDGUARDS AND WHEEL PROTECTION

43.02

The front mudguard must cover the circumference of the wheel at an angle sufficient enough to protect the rider from mud.

43.04

The rear mudguard measure described in the figure must not be exceed 130mm at the most extended positions of the front and the rear suspension, at full extension (see diagram L).

43.05

The ends of the mudguards must be rounded. The radius must be at least 3 mm. Mudguards must be made of flexible materials only (i.e. plastic).

43.07

If cast or welded wheels are used, a protection must be provided by enclosing the spokes with solid discs. Any open area between the outer edge of the solid disc and the wheel rim shall be maximum 10 mm (tyre inflation valve excepted).

01.45 STREAMLINING

For the main article, refer to the same number in the General section

01.46 SUSPENSION

Electronically controlled suspension systems may not be used.

01.47 WHEELS, RIMS, TYRES**47.03 Restrictions for wheel (rim) dimensions**

Capacity	Maximum front wheel (rim) size	Maximum rear wheel (rim) size
65cc	14 inch	12 inch
85cc SW (small wheels)	17 inch	14 inch
85cc LW (large wheels)	19 inch	16 inch
125cc and up	21 inch	19 inch

65cc: front wheel, maximum 14 inch
rear wheel, maximum 12 inch

85cc: front wheel, maximum 19 inch
rear wheel, maximum 16 inch

01.49 TYRES FOR MOTOCROSS

49.02

Scoop or paddle (continuous radial rib) tyres and/or tyres with lugs having a height of over 19.5 mm are forbidden.

49.04

The tyre surface shall not be fitted with subsequently mounted elements such as anti-skid spikes, special chains, etc.

01.51 ADDITIONAL SPECIFICATIONS FOR SUPERMOTO

The following specifications will apply for motorcycles entering the SuperMoto World Championship:

- There must be a clear colour distinction between the colour of the background and the colour of the number. Reflecting numbers are forbidden. Thus, with exception of a red front number plate with white numbers, riders have the free choice of colour for number plates and colours. The front red number plate with white numbers is compulsory for, and must be displayed by the current leader in each class of the Championship.
- A safety device (pin or lock nut) should be installed on the brake pad fixture.
- The safety wire used on the bolts of the brake callipers, must be visible.
- On 4-stroke engines, an oil catch tank of 0.5 litres minimum, properly fastened, or a closed breather system must be installed.
- Motorcycles must be equipped with a protective shield, installed under the engine to act simultaneously as a protection and as a reservoir, be designed to collect the loss of oil or coolants which may occur in case of an engine breakdown.
- One or several leak-proof catch tanks must be provided for the radiator water and the breather system of the fuel tank. These catch tanks must be emptied before each start.
- The only authorised cooling liquid is water.

- The safety wire used on oil and water filter caps, as well on drain plugs, must be visible.
- Motocross, enduro or trial tyres are prohibited.
- The maximum tread depth on the front and/or back tyres used must be 10 mm in the middle.
- Additional tread grooves, cuts, etc. are allowed on the front and/or back tyres.

01.53 ADDITIONAL SPECIFICATIONS FOR SIDECARS

For the main article, refer to the same number in the General section

01.55 NUMBER PLATES

They must be fitted as follows :

55.03

Number plates must be made of flexible materials only (i.e. plastic). The shape of the front number plate is free and may be part of the general design of the motorcycle.

However, the front number plate must have a minimum size to carry 3 digit numbers of the figure stated in Art. 55.07 and the Motocross World Championship logo.

Team publicity is allowed on the front number plate within a space 50mm from the top or bottom section of the number plate.

55.04

The plates curved not more than 50 mm out of a true plane must not be covered or bent.

55.05 Front number plates

The front number plates curved not more than 50 mm out of a true plane must not be covered or bent.

One plate must be fixed to the front inclined not more than 30° rearwards from the vertical. Holes can be perforated between the numbers on the number plate. However, under no circumstances must the actual numbers be perforated.

For the solo classes of the Individual Motocross World Championship events, the front number plate must always display (See Appendix "O"):

- a) The background color,
- b) The number of the rider,
- c) The FIM Motocross World Championship logo as shown on the diagram (5 cm x 5 cm).

The numbers must be clearly legible. Reflecting numbers are forbidden. The following minimum dimensions must be respected on the front number plate:

- | | |
|---|--------|
| - Height of the number | 140 mm |
| - Width of each number | 70 mm |
| - Width of the stroke | 25 mm |
| - Space between two numbers | 15 mm |
| - Space between the FIM logo and the number | 10 mm |

55.06 Side number plates

The side number plates must be positioned above a horizontal line drawn through the rear wheel spindle and the front edge of the plate must be behind a vertical line drawn at 200 mm to the rear of the rider's footrest.

They must be fixed in such a manner as to be clearly visible and they must not be marked by any part of the motorcycle or by the rider when seated in the driving position.

In place of separate plates, a space of equivalent size in matt colours can be painted or fixed on the bodywork.

For the solo classes of the Individual Motocross World Championship events, the side number plate must always display (See Appendix "E"):

- a) The number of the rider,
- b) The FIM Motocross World Championship logo (5cm x 5cm),
and
- c) Optionally, publicity of the rider's/team's sponsor(s).

There is freedom of design and publicity, but incorporation of the rider's number and the FIM Motocross World Championship logo into the graphics is compulsory.

The color scheme for the background of the side number plates and the numbers is free. However, there must be a clear color distinction between the color of the number and the color of the background. The FIM logo must be in black or white.

55.07

The figures must be clearly legible and like the background must be painted in matt colours to avoid reflection from sunlight. In general, the following minimum dimensions must be respected on front number plates:

Height of figure:	140 mm
Width of figure:	70 mm
Width of stroke:	25 mm
Space between 2 figures:	15 mm

However, the following minimum dimensions must be respected on the side number plates:

Height of figure:	100 mm
Width of figure:	70 mm
Width of stroke:	25 mm
Space between 2 figures:	15 mm

55.08

The English form for numbers must be used. That is single vertical line for the “one” and a simple sloping line without a horizontal line for the “seven” (see diagram O).

55.09

All other number plates or markings on a motorcycle liable to cause confusion with the number must be removed before the start of a competition.

Whenever official time keeping methods (transponders) are being used in the FIM World Championships and Motocross of Nations events, competitors will be allowed to put publicity on:

- the front number plate (for dimensions, see Art. 55.03). Publicity may be put within a space, 50 mm from the top or bottom section of the number plate, (See diagram O, the shaded area is reserved for publicity).
- the side number plates: the entire number plate may be used for publicity space. For Motocross des Nations, the FMN's national flag must be put on the side number plates, however respecting the dimensions.

55.12 Number plate colours

The background colours and figures vary according to the class of motorcycle and the type of competition, the the main rules being indicated in the Supplementary Regulations for each meeting.

The following colours shall be used ; and they must be matt colours, following the RAL colour table, i.e. :

Black	9005
Yellow	1003
Green	6002
White	9010
Blue	5005

The following colour schemes shall be used :

MX1	White background	Black Numbers / Logo FIM
MX2	Black background	White Numbers / Logo FIM
MX3	Yellow background	Black Numbers / Logo FIM
Women's MX	Blue background	White Numbers / Logo FIM
World Champion (1st event)	Red background	White Numbers / Logo FIM
Points leader	Red background	White Numbers / Logo FIM
MX des Nations	According to class	
MXN - Winning Team	Red background	White Numbers / Logo FIM
Sidecar	Yellow background	Black Numbers
Veteran World Cup	Yellow background	Black Numbers / Logo FIM
Supercross	White background	Black Numbers / Logo FIM

55.13 For all other events :

85 cc	white background	black numbers
125 cc	black background	white numbers
250 cc	green background	white numbers
500 cc (open)	yellow background	black numbers
Sidecars	yellow background	black numbers
Supercross	white background	black numbers

01.63 FUEL, OIL AND COOLANTS

All motorcycles must be fuelled with unleaded petrol, as this term is generally understood.

For the main article, refer to the same number in the General section

01.65 EQUIPMENT AND PROTECTIVE CLOTHING **Clothing and footwear**

During practising and racing, the riders and passengers must wear the following clothing and footwear:

65.01

For Motocross

The rider and passenger must wear trousers and gloves of durable material. For riders only knee-length boots of leather or an equivalent material must be worn. In order to prevent abrasions, in an accident, the arms of riders and passengers must be entirely covered by a protective garment of a suitable material.

For Snowmobiles

The rider must wear suitable clothing to afford protection against the cold and against injury in case of a fall and padded knee-length boots or other solid footwear.

For Supermoto

Riders must wear a complete leather suit' **of one piece**, with a recommended minimum thickness: 1,2 mm and with additional leather padding or other protection on the principal contact points, knees, elbows, shoulders, hips, etc.

Sections of the leather suit not directly subject to 'crash' damage may use a small limited area or strip made of a materials which have the same protective properties as leather (see Art. 65.07 in the General Section).

Linings or undergarments must not be made of a synthetic material which might melt and cause damage to the riders' skin.

Riders must also wear leather gloves and boots, which with the suit provides complete coverage from the neck down.

The use of a back protector is highly recommended.

65.07 Material equivalent to leather

For the main article, refer to the same number in the General section

65.08 Approval

FMNs (National Motorcycling Federations) which approve protective clothing must present the certificate of a testing institute to the FIM for their records. The suits must carry an FMN approval mark, only if required by the FMN.

01.67 WEARING OF HELMETS

For the main article, refer to the same number in the General section

01.69 HELMET OPERATIVE INSTRUCTIONS

For the main article, refer to the same number in the General section

01.70 RECOGNISED INTERNATIONAL HELMET APPROVAL MARKS

- Europe ECE 22-05 (P ou J)
- Japan JIS T 8133 : 2000 - **(until 31.12.2011)**
JIS T 8133 : 2007
- USA SNELL M 2005 - **(until 31.12.2011)**
SNELL M 2010

(see International Helmet Standards in diagram section)

01.71 EYE PROTECTION

For the main article, refer to the same number in the General section

01.73 NATIONAL COLOURS FOR HELMETS

For the main article, refer to the same number in the General section

01.75 BADGE OF THE FIM

For the main article, refer to the same number in the General section

01.76 NUMBER SASHES (BIBS)

Starting numbers to be worn on sashes (bibs) or printed on the riders' jersey must be conforming to the following:

76.01

The colour of the number must be in strong contrast with the colour of the background.

76.02

Distance between the numbers: 1.5 cm

76.03

Height of number: minimum 20 cm

76.04

Width of number: minimum 10 cm for one digit numbers
 minimum 20 cm for two digit numbers
 minimum 25 cm for three digit numbers

76.05

Width of stroke: 3 cm

76.06

Minimum free space around the number without publicity: 5 cm

76.07

Bibs if manufactured from plastic material must be perforated to provide adequate ventilation.

76.08

Starting numbers used by riders on number sashes or tee-shirts must be in compliance with the starting number of the race in question. Furthermore they must be worn during the practices as well as during the races.

01.77 CONTROL

77.01 Verification

General

A rider is at all times responsible for his machine.

For the main article, refer to the same number in the General section

77.02.2 The rider or mechanic must present clean motorcycles in conformity with the FIM rules. He must also present a duly filled in and confirmed technical card. The fuel tank shall only contain maximum 0.5 litre fuel. In case of doubt, the Chief Technical Steward will measure the weight with an empty tank.

77.02.3 The rider must present his equipment. The helmet must be marked.

77.02.5 The sound test must be carried out first and the sound level reached will be recorded in the technical card. The exhaust silencer will be marked with paint.

77.02.6 The motorcycle(s) must be weighed and the weight recorded in the technical card.

77.02.7 An overall inspection of the motorcycle(s) must be carried out in conformity with the FIM rules and the motorcycle(s) will be sealed (seal on the front main frame).

77.02.8 Each rider must present one motorcycle at scrutineering under his name and number. As for the second motorcycle, there are two possibilities :

- 1) A rider can present a second motorcycle to scrutineering, under his name and number ;
- 2) A team or a group of riders can present a second motorcycle to scrutineering, with the possibility to have it used by several riders, under the condition that the motorcycle has been marked under the riders' name and number. In this case, the team presenting the motorcycle must indicate at the moment of scrutineering, the names and numbers of the riders eligible to use this motorcycle.

77.02.9 The rider may change the motorcycle between races. The final choice must be made a minimum of 10 minutes before the start of each race.

77.02.10 Before each start and in the waiting area, the technical steward will carry out the control of the seals and marks on the exhaust system and the riders' equipment.

77.02.11 During the event the technical steward will control the seals, marks on the exhaust system and the riders' equipment in the repair zone. He must follow the work being carried out on the machines in order to ensure that no motorcycle becomes a source of danger.

77.02.12 Immediately after the last race the first 3 motorcycles will be placed in a closed park for technical control. The machines must remain in the closed park for 30 minutes after the arrival of the winner, in case of a protest or should further examination be required.

Competitors must retrieve their machines within 30 minutes after the opening of the closed park area, except for the machines which are chosen for disassembly. After this time limit, the closed park officials will no longer be responsible for the machines left behind.

77.02.13 After the technical control has been completed the Chief Technical Steward will submit to the Clerk of the Course a list stating the names of the accepted riders and machines, the sound levels and weights of machines.

77.02.14 If a motorcycle is involved in an accident, the technical steward must check the machine to ensure that no defect of a serious nature has occurred. However, it is the responsibility of the rider to present his machine for this re-examination together with helmet and clothing.

If the helmet is clearly defective, the technical steward must retain this helmet. The organiser must send this helmet, together with the accident and medical report (and pictures and video, if available) to the Federation of the rider. If there are head injuries stated in the medical report, the helmet then must be sent to a neutral institute for examination.

77.05 Dangerous machines

For the main article, refer to the same number in the General section

01.79 SOUND CONTROL

IMPORTANT

- The surrounding sound should not exceed 90 dB/A within a 5 metres radius from the power source during tests.

- For the initial sound control and technical inspection, a rider (or his mechanic) shall present only one (1) spare silencer per machine.
- Other spare silencers may be presented after all participants have presented their motorcycles, or on the following days of the event.
- During the sound test method, machines not equipped with a gear box neutral must be placed on a stand.
- The sound level for engines with more than one cylinder will be measured on each exhaust end.
- During the sound test, only the rider may take place on the machine in the normal riding position. No other team personnel may influence the sound test.
- A machine which does not comply with the sound limits can be presented several times at pre-race control.
- The silencers will be marked when they are checked and it is not allowed to change them after the verification, except for any spare silencer which has also been checked and marked.
- All silencers will be checked and marked, once they have successfully passed the sound check. The end opening of the silencer shall remain unmodified once it has been checked and marked.
- Silencers fitted with adapters aimed to reduce the sound level shall be permanently fitted.

79.01 The '2 metre max' method – Maximum sound levels

For further details on the '2 metre max method, refer to the same number in the General section (Art. 79.01).

Sound levels in MX1, MX2, MX3, MXoN, Women's and Veteran's classes will be verified with the '2 metre max' method (Art. 79.01).

- **Before and during practice session and the races: 115 dB/A.**
- **After the races: 116 dB/A**

Note: The admissible sound levels for the neighbouring inhabitants and the environment will be the following:

- For all motocross events: 81 dB/A at 100m.
- The sound will be measured with a calibrated and homologated sound meter at a distance of 100m, perpendicular to the axis of the race track.
- A tolerance of +5 dB/A will be added to these values.

79.02 The 'FIM static test' method

Sound levels in the MX Juniors, Sidecars, Supermoto and Snowcross World Championship events will be measured with the 'FIM static test' method.

To evaluate the sound levels in these classes, it is preferable to use the '2 metre max' method. If a silencer exceeds the limit, the FIM 'static test' method shall apply.

With the FIM 'static' test method, the microphone shall be placed at 50 cm from the exhaust pipe, at an angle of 45° measured from the centre-line of the exhaust end and at the height of exhaust pipe, but at least 20 cm above the ground. If this is not possible, the measurement can be taken at 45° upwards.

79.02.01

During the sound test, only if requested by the Chief Technical Steward, every motorcycle shall be equipped with an extension (min. 30 cm) to the spark plug cable, to allow detection of the rpm level. One end of this extension must be plugged into the original spark plug cap, the other end has another spark plug cap and fitted normally on the spark plug.

79.02.2

The rider shall keep his engine running and shall increase the engine speed until it reaches the specified Revolutions per Minute (RPM). Measurements must be taken when the specified RPM is reached.

79.02.3

The RPM depends upon the mean piston speed corresponding to the stroke of the engine.

The RPM will be given by the relationship :

$$N = \frac{30,000 \times cm}{l}$$

in which N = prescribed RPM of engine
 cm = fixed mean piston speed in m/s
 l = stroke in mm

Apparatus for sound control must be to international standard IEC 651, Type 1 or Type 2.

The sound level meter must be equipped with a calibrator for control and adjustment of the meter during periods of use.

The “slow response” setting must always be used.

79.02.4

The piston speed for Motocross (13m/s) is an equivalent approximate figure, for reference. For convenience, made possible by the similarity of engine stroke on current Motocross machines, within capacity classes, the test will be conducted at a fixed RPM :

Up to 85 cc	8,000 RPM
Over 85 cc up to 125 cc	7,000 RPM
Over 125 cc up to 150 cc (4T).	6,000 RPM
Over 125 up to 250 cc	5,000 RPM
Over 250 cc up to 500 cc	4,500 RPM
Over 500 cc	4,000 RPM

79.02.6 Sound limits in force using the FIM ‘static method)

The maximum sound limit is set at :

- Max. 96 dB/A for motorcycles with a two stroke engine.
- Max. 94 dB/A for motorcycles with a four stroke engine.

79.02.7 Sound control during and after the competition

In a competition which requires a final examination of machines before the results are announced, this examination must include a sound control measurement of at least three machines chosen at the discretion of the Clerk of the Course in co-operation with the Chief Technical Steward

01.80 GUIDELINES FOR USE OF SOUND LEVEL METERS

For the main article, refer to the same number in the General section

01.81 TIMEKEEPING

Since 01.01.1993, the responsibility for Timekeeping has been referred to the Sporting Commission.

01.82 SPECIFICATIONS FOR SNOWMOBILES

82.01 Introduction

Snowmobiles are vehicles driven on one or more caterpillar tracks steered by skis generally situated at the front or side of the vehicle either permanently or temporarily attached. There are several types of snowmobiles.

82.01.1 Snowmobiles equipped with 2 caterpillar tracks with one or two steering skis in front of the vehicle.

82.01.2 Snowmobiles equipped with one caterpillar track with one or two steering skis in front.

82.01.3 Snowmobiles equipped with one caterpillar track and skis.

For safety reasons, no windscreen of plastic or similar material shall be used.

82.02 General Specifications

82.02.1 The position of the engine is optional, except it must be positioned in front of the rider.

82.02.2 The rider must be completely visible.

82.02.3 It is forbidden to add air foils or spoilers to the original hood or cowling.

82.02.4 The use of Titanium is strictly forbidden.

82.02.5 The rear tunnel opening must be enclosed with a comparable tunnel material.

82.02.6 Front headlights(s) must be removed or covered.

82.02.7 Machines must be equipped with red rear lamp, minimum power 20W. Minimum dimensions of rear lamp: 40 mm x 50 mm.

82.02.8 It is forbidden to drive on the track without hood or cowling.

82.03 Starting devices

Obligatory.

82.04 Open transmission guards

Snowmobiles must be equipped with belt guards. The guards must be separate from the cowl configuration.

82.05 Exhaust pipes

82.05.2 Exhaust fumes must not discharge in a manner as to raise snow, foul the tracks or brakes, or inconvenience a passenger, if there is one, or any other riders. All possible measures must be taken to prevent the possible loss of waste oil so that it does not inconvenience a following rider.

82.06 Handlebars

The width of the handlebars is : not less than 500 mm and not more than 850mm. No extensions are permitted.

82.07 Control levers

Compulsory. Article 01.35 is applicable.

82.08 Throttle controls

Compulsory. Article 01.37 is applicable. Ball ends are not obligatory.

82.09 Footrests (See Article 01.39)

If snowmobile footrests are equipped with loops, the footrest must have a stopper which would prevent the riders foot entering by more than 1/3 of its length.

82.10 Brakes

There must be at least one brake.

82.11 Snow Flaps

Snowmobiles must be equipped with snow flaps at the rear. They must be made of an adequate material. There must be at least 30 mm overlap on each side of the machine tunnel and a maximum of 100 mm ground clearance when the machine is unloaded. The use of springs and/or elastic material to hold down the snow flaps is forbidden. (See diagram M.)

82.13 Driving tracks

These must be made of rubber or plastic. No modifications may be made to driving tracks. Anti-slip devices such as studs, spikes etc., cannot be fitted.

82.15 Steering skis

The steering ski shall be designed to push away obstacles sideways and vertically (see diagram M).

The front edge shall be raised in a curve with a diameter of not less than 100 mm which shall continue to a vertical line through the centre point of the bending circle created by the curve. Material to be used: minimum 12 mm outside diameter.

Any guide rail must be made of circular material with a minimum diameter of 10 mm. If equipped with anti-skid rail, minimum profile angle 60° and maximum length 260 mm (see diagram M).

The edges of steering skis must be rounded at least with 5 mm profile of steel or another metal (see diagram M).

82.17 Number plates

Compulsory. Article 01.55 is applicable.

82.18 Number plate colours

Up to 250 cc	green background	white numbers
350 cc	blue background	white numbers
500 cc	yellow background	black numbers
1050 cc	white background	black numbers
1300 cc	red background	white numbers

82.19 Fuel and Oil

Article 01.63 is applicable. Anti-freeze liquid is permitted.

82.20 Equipment and protective clothing

Article 01.65 is applicable.

82.21 Bibs

Article 01.76 is applicable.

82.22 Control/Verification

Article 01.77 is applicable.

82.23 Sound control

Article 01.79 is applicable. During a snowmobile sound test, the machine must be placed on a bridge 1m off the ground, with a microphone placed at an angle of 90° at a distance of 100 cm from the exhaust pipe. All power train must be released from the engine. Hood and cowling must be installed.

Sound levels: maximum 104 dB/A measured, in principle at 13 m/sec mean piston speed. For convenience, the sound test will be conducted at a fixed engine speed of 4'000 RPM.

The maximum sound level is: 100 dB/A @ 4000 RPM.

At the final sound test examination the tolerance will be 1 dB/A.

01.83 SPECIFICATIONS FOR QUAD RACERS**83.01 Definition**

Refer to Article 01.7/Classes - Group G/Quad Racers, for definition.

83.02 Type of motorcycle

There is no restriction placed on the make, construction of type of motorcycle, other than specified below. The cylinder capacity must be min. 250 cc and max. 350 cc (2 cylinders max.) and 500 cc (1 cylinder). The drive must be through the rear wheels only via a solid axle.

83.03 Wheels

Wheel rim diameter max.: 12 inches.

There is no restriction for the size of the front wheel. It is forbidden to use wheels with spokes.

Every front wheel must have a functional brake installed on axle and operated by a handlebar mounted lever.

On the rear, the vehicle must have a brake on each wheel or a brake fixed solidly on the rear transmission axle of the wheels, operated by a lever on the handlebar or by a foot operated pedal.

Wheels must be protected by good mudguards of soft, synthetic materials.

83.04 Tyres

Article 01.49 is applicable.

83.05 Overall width

The maximum overall width cannot exceed 1300 mm.

83.06 Protection

A crash bar must be placed behind the seat. The length and width of the crash bar must end above the rear section of the chain sprocket.

A crash 'bar' or 'guard' must be fixed at the front and the rear of the vehicle. This protective barrier must be fitted in such a way that it is in alignment with the outside flange of the wheels.

A protective barrier (or 'guard') of a round profile (minimum diameter: 25 mm) must be installed on each side of the vehicle. There shall be no prominent (sharp) parts.

A structure of crossed belts or a metallic grid must be fitted to fill the opening between the wheels and the barrier, to prevent the riders' foot from accidentally touching the ground.

83.07 Control levers and handlebars

Articles 01.33 and 01.35 are applicable.

83.08 Throttle controls

Article 01.37 is applicable.

83.09 Sound

Article 01.79 is applicable.

83.10 Number plates

Four number plates are required :

83.10.1 1 plate fixed to the front of the machine at the level of the head lamp, facing forward

83.10.2 1 plate on each side of the machine placed on the rear mudguard.

83.10.3 1 plate attached to the rear bumper.

83.10.4 The plates must have a yellow background with black numbers. They must be placed centrally and as vertical as possible. See Article 01.55 for dimensions.

83.10.5 The rider must display his starting number on his jersey or a bib.

83.11 Helmets and clothing

Articles 01.65 to 01.71 are applicable.

83.12 General

The vehicle must be in perfect technical condition and must satisfy the requirements of the Technical Steward.

DIAGRAM / DIAGRAMME

L

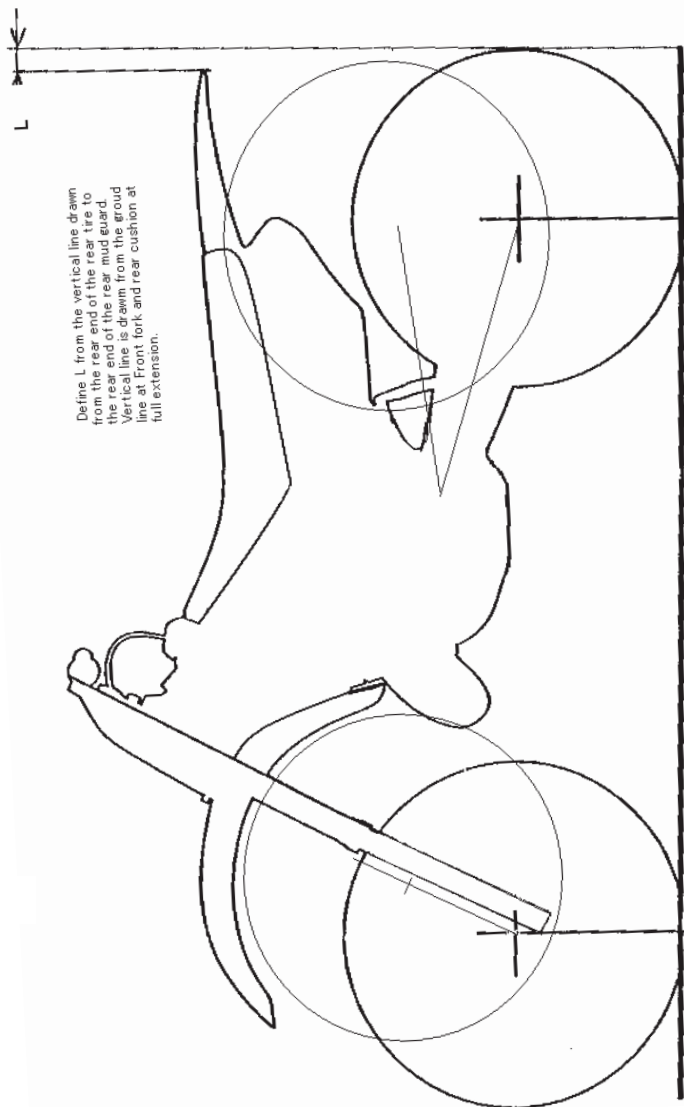

CMS

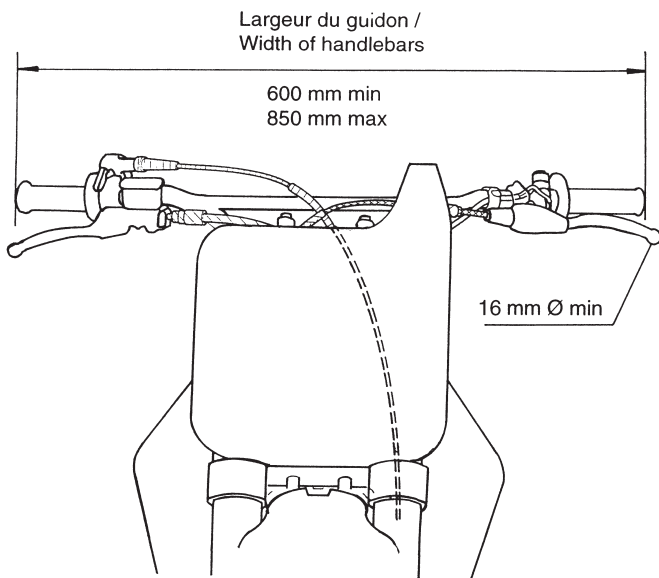

FRONT NUMBER PLATE / PLAQUE FRONTALE

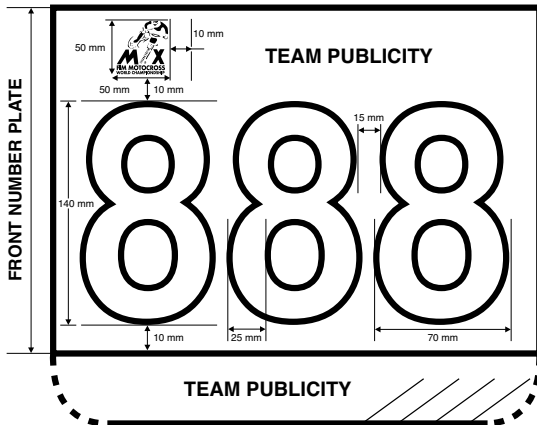

SIDECAR

F

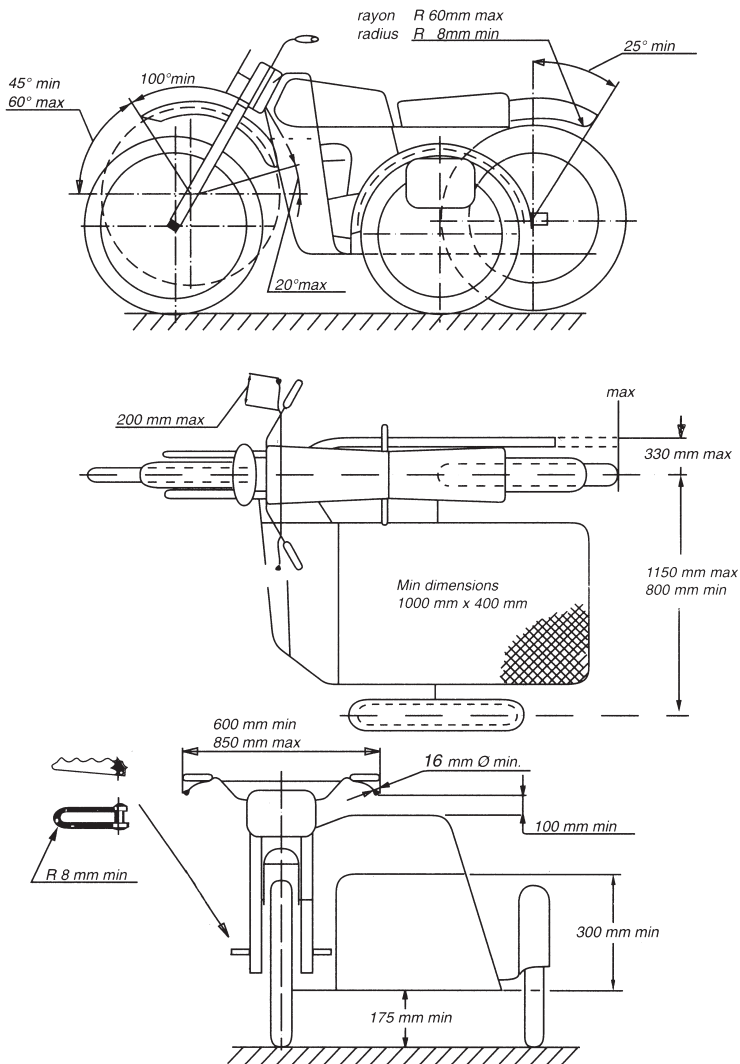

SNOWMOBILE SCOOTER/NEIGE

M

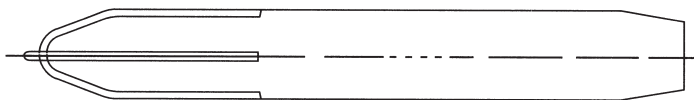
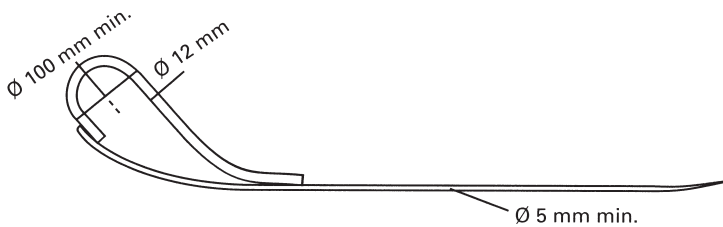
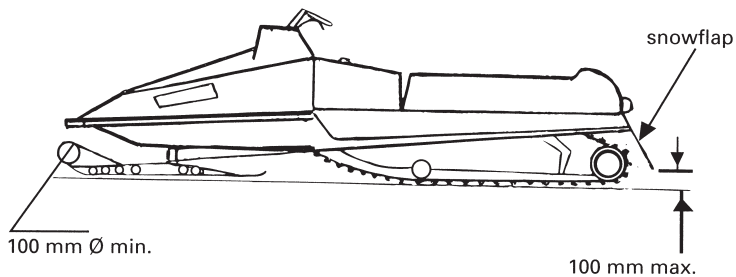

CMS

DIAGRAMME Q QUAD RACER

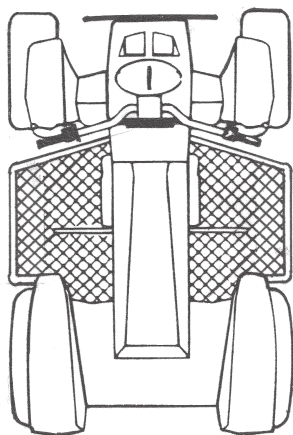
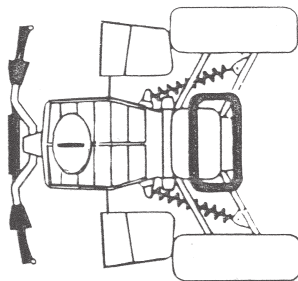

Max. 1300 mm.

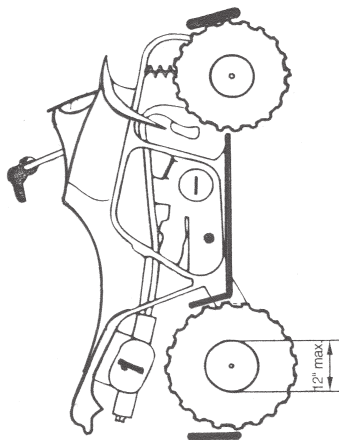

112" max

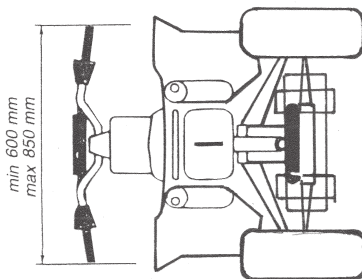

min 600 mm
max 850 mm

DIAGRAMME Q (suite)

PROTECTIVE DEVICES (REAR) : sprocket and disc SYSTEMES DE PROTECTION (AR): couronne et disque

- (1) Chain guard, mounting to a height corresponding to minimum 90°
Sabot inférieur remontant à la hauteur correspondant à 90° minimum

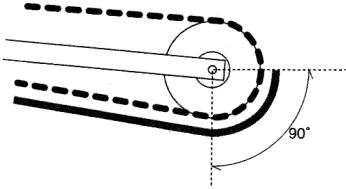

- (2) Chain guard + (3) protective guard
Sabot inférieur + (3) barre de protection

