



FÉDÉRATION INTERNATIONALE DE MOTOCYCLISME

**FIM Standards for  
Track Racing Circuits  
(STRC)**

**2010**

***Normes de Pistes FIM pour les  
Courses sur Pistes  
(NPCP)***

**FIM Standards for  
Track Racing Circuits  
(STRC)**

***Normes de Pistes FIM pour les  
Courses sur Pistes  
(NPCP)***

Articles ammended as from 01.01.2010 are in bold type  
*Les articles modifiés dès le 01.01.2010 sont en caractères gras*

---

**EDITION 2010**

## Contents / Sommaire

Appendix	079	Standards for Track Racing Circuits (STRC).....	1 - 24
		Track Inspection Report.....	25 - 28
		Drawings .....	29 - 61
		Appendix A.....	62 - 63
Annexe	079	<i>Normes de Pistes pour les Courses sur Pistes (NPCP).....</i>	<i>1 - 24</i>
		<i>Rapport d'Inspection de Piste.....</i>	<i>25 - 28</i>
		<i>Illustrations .....</i>	<i>29 - 61</i>
		<i>Annexe A .....</i>	<i>62 - 63</i>

## APPENDIX 079

### STANDARDS FOR TRACK RACING CIRCUITS (STRC)

<b>079.1</b>	<b>GENERAL .....</b>	<b>3</b>
<b>079.2</b>	<b>INSPECTION AND HOMOLOGATION PROCEDURE .....</b>	<b>3</b>
079.2.1	Request for a track inspection .....	3
079.2.2	Homologation procedure .....	3
079.2.3	Persons necessary for a track inspection .....	4
079.2.4	Expenses for a track inspection .....	4
079.2.5	Duties of the track inspector .....	4
079.2.6	Track inspection report .....	5
079.2.7	Allocation of an FIM World Championship .....	5
079.2.8	Liability .....	5
<b>079.3</b>	<b>TRACK LAYOUT .....</b>	<b>5</b>
079.3.1	General principles .....	5
079.3.2	Recommended dimensions .....	5
079.3.2.1	Length of the track .....	6
079.3.2.2	Width of the track .....	6
079.3.3	Banking .....	7
079.3.4	Surfacing .....	7
079.3.5	Maintenance .....	8
079.3.6	Track requirements and equipment .....	8
<b>079.4</b>	<b>PROTECTIVE DEVICES AND BARRIERS .....</b>	<b>9</b>
079.4.1	Safety barriers for natural & artificial Ice tracks ...	9
079.4.2	Safety fence for Speedway, Long & Grass tracks	9
079.4.3	Wooden fence .....	10
079.4.4	Wire mesh fence .....	10
079.4.5	Safety barriers on temporary tracks .....	11
079.4.6	Additional Protective Devices .....	12
079.4.6.1	Homologation procedure of new Additional Protective Devices..	13

	079.4.7	Kick board .....	14
	079.4.8	Access gates.....	14
	079.4.9	Neutral zone.....	14
<b>079.5</b>	<b>MARKING</b> .....		<b>15</b>
	079.5.1	Marking of the outer edge.....	15
	079.5.2	Marking of the inside edge .....	15
<b>079.6</b>	<b>INFIELD AND ADVERTISING</b> .....		<b>16</b>
	079.6.1	Infield.....	16
	079.6.2	Advertising .....	16
<b>079.7</b>	<b>TRACK INSTALLATIONS</b> .....		<b>17</b>
	079.7.1	Starting area.....	17
	079.7.2	Starting line .....	17
	079.7.3	Starting gate.....	18
	079.7.4	Signalling.....	19
	079.7.5	Light signals .....	19
	079.7.6	Referee's box .....	20
	079.7.7	Pits .....	20
	079.7.8	Changing room.....	21
	079.7.9	Washing of motorcycles .....	22
<b>079.8</b>	<b>EMERGENCY SERVICE</b> .....		<b>22</b>
	079.8.1	Medical service .....	22
	079.8.2	First-aid room.....	22
	079.8.3	Fire-fighting equipment & emergency tools.....	23
	079.8.4	Fuel .....	23
<b>079.9</b>	<b>PRESS FACILITIES</b> .....		<b>23</b>
<b>079.10</b>	<b>FIM SPEEDWAY WORLD CHAMPIONSHIP GRAND PRIX &amp; FIM SPEEDWAY WORLD CUP</b> .....		<b>24</b>

## APPENDIX 079

### STANDARDS FOR TRACK RACING CIRCUITS (STRC)

#### 079.1 GENERAL

The "Standards for Track Racing Circuits" (STRC) determine the necessary standards for obtaining an FIM Track Racing licence.

The FIM Championships must be held on Track Racing circuits which are homologated by the FIM, as stipulated in the FIM Sporting Code under Art. 10.8.

#### 079.2 INSPECTION AND HOMOLOGATION PROCEDURE

##### 079.2.1 Request for a track inspection

Each FMN can apply for a track inspection by the FIM Executive Secretariat. Every application for an FIM track inspection must be submitted together with an accurate plan-drawing of the track to the scale 1:500. This plan-drawing must also indicate the pits area, the changing room, the amenities and accommodation for the public, as well as all relevant dimensions and necessary information.

An accurate construction-drawing of the safety barrier to the scale 1:10 must also be submitted.

##### 079.2.2 Homologation procedure

During the year, the CCP Executive Secretariat will receive all documentation (track inspection reports, relevant remarks and conclusions contained in previous reports from the Jury Presidents and Referees) for all tracks hosting World Championship meetings.

The CCP Executive Secretariat will examine the documentation and make the following recommendations to the CCP, at the time of the Congress or Biennial Session, concerning the tracks that have been proposed by the FMNs for the meetings of the following year:

- a) The track is in order, and there are no remarks concerning the organisation.
- b) The FMNR and the organisers must be advised about the improvements to be carried out, and must confirm in writing that they have been completed within the deadline set by the CCP.
- c) A re-inspection is requested for the track, or the FMNR is requested to change the venue to another track conforming to the standards.

A track inspector will be appointed by the CCP in order to control and possibly recommend a homologation for:

- a) Any track to be used for an FIM Championship for the first time, or where no current licence is in force.
- b) Existing tracks that have already been used for an FIM Championship, but have undergone substantially changes affecting the circuit or the safety installations.
- c) Existing tracks holding a valid licence, but where a serious accident has occurred due to the circuit, its safety installations or something else connected with the circuit.
- d) Any particular track following a request from the CCP Executive Secretariat.

A track complying with all the recommendations and conditions of a final track inspection report will be homologated by the CCP and will receive an FIM track licence.

The licence is valid for 3 years.

In exceptional cases, an FIM track licence may be valid for only one or two years.

### **079.2.3 Persons necessary for a track inspection**

The appointed CCP track inspector will be accompanied by the following persons:

- A qualified member of the FMNR
- A qualified representative of the owner of the track or the organising club
- A rider (this is highly recommended)

### **079.2.4 Expenses for a track inspection**

The costs of the different track inspections are determined under Art. 7.6 of the FIM Financial Operating Guidelines.

### **079.2.5 Duties of the track inspector**

At all inspections, the duty of the appointed track inspector is to examine all the installations and safety features and environmental elements at the circuit, and make recommendations, where required, to ensure that these, and the necessary services conform to the STRC and to the FIM Environmental Code.

The CCP or the CCP Executive Secretariat may ask for a second inspection if essential work or faults remain.

#### **079.2.6 Track inspection report**

The appointed track inspector must complete the track inspection report by computer and send it by e-mail to the FIM Executive Secretariat and FMN concerned within a few days of the track inspection. The original signed document must be sent by mail afterwards. In the track inspection report, the track inspector clearly writes down his remarks and proposals with regard to the measures to be adopted or improvements to be made.

Once the inspection report has been sent, the FMN concerned has a maximum of three weeks to comment on the said report.

#### **079.2.7 Allocation of an FIM World Championship**

Each FMN which has been allocated an FIM Championship for the next year, at the time of the Conference Meetings, must advise the FIM Executive Secretariat of the venue(s) of the meeting(s) within the deadline stipulated by the CCP (1<sup>st</sup> August of the current year).

#### **079.2.8 Liability**

No legal action can be taken against the FIM; a track inspector or any FIM official for any reason connected to the homologation of a track, the track installations or the track standards.

### **079.3 TRACK LAYOUT**

#### **079.3.1 General principles**

The track must be on level ground and formed by two straights joined by two semi-circles.

#### **079.3.2 Recommended dimensions**

The dimensions of the track, as laid down, are recommendations which have to be followed as far as possible.

### 079.3.2.1 Length of the track

Measured 1 metre from the inside edge:

<u>Speedway tracks:</u>	From 260 m to 425 m
<u>Ice tracks:</u>	From 260 m to 425 m
<u>Long &amp; Grass tracks:</u>	From 426 m to 1300 m
<u>80cc Speedway:</u>	From 120 m to 200 m
<u>125cc Grass Track:</u>	From 200 m to 800 m
<u>250cc Speedway:</u>	From 200 m to 425 m
<u>250cc Long Track:</u>	From 426 m to 800 m
<u>1000cc TR Sidecar</u>	From 300 m to 700 m

### 079.3.2.2 Width of the track

The minimum width of the track shall be:

#### **Straights:**

<u>Speedway tracks:</u>	10 m
<u>Ice tracks:</u>	10 m
<u>Long &amp; Grass tracks:</u>	12 m
<u>80cc Speedway:</u>	7 m
<u>1000cc TR Sidecar:</u>	
Track up to 400 m	10 m
Track from 400 to 700m	12 m

**Bends:**

Speedway tracks: 14 m

Ice tracks: 11 m

Long & Grass tracks: 15 m

80cc Speedway: 10 m

1000cc TR Sidecar:

Track up to 400 m 14 m

Track from 400 to 700m 14 m

**079.3.3 Banking**

Speedway, Long & Grass tracks:

If there is some banking on the track, it must under no circumstances exceed 5% in the straight, 10% in the bends and must remain constant and grow from the inner edge to the safety fence.

**079.3.4 Surfacing**

For Speedway, Long & Grass tracks:

Asphalt, macadam, concrete or similar solid base ground is not permitted, unless special authorisation is given by the CCP. The granulation of the material used for the top dressing must not exceed 7 mm. The depth of the dressing should not be less than 3 cm. In no circumstances should the granules be large enough to cause injury to the riders. The top dressing must not include toxic or other materials which could affect the health of the riders or be treated with salt, oil or any substances which could corrode or damage in any other way the components of racing motorcycles.

Speedway tracks:

The top surface must be granite, shale, brick granules or similar unbound material rolled in on the base ground.

Ice tracks :

The top surface must be ice with a minimum thickness of 10 cm.

### Long tracks :

The top surface must be sand, shale, or similar unbound material rolled in on the base ground.

### Grass tracks :

The top surface must be firm, level turf. Only minor undulations are permitted.

## **079.3.5 Maintenance**

### Speedway, Long & Grass tracks:

The track should be properly watered down in ample time before the meeting to ensure satisfactory racing and to protect the public and the riders from dust. Water must also be available to control dust during the racing.

To preserve the evenness of the top dressing, it should be graded as necessary between heats. Graders should be constructed so that they replace the top dressing on the inside area of the track from the outside where it has been thrown during racing.

### Ice tracks:

To remove loose ice, the surface must be scraped or brushed as necessary, but at least after every four races. The loose ice shall be removed from the surface of the track so that the edge marking remains clearly visible to the riders and the Referee. For this purpose power-driven scrapers or brushes must be provided.

## **079.3.6 Track requirements and equipment**

The track is in order when the track surface ensures satisfactory riding and overtaking. In order to obtain this, all necessary equipment such as graders, water tankers, etc. have to be provided at all Track Racing meetings.

## 079.4 PROTECTIVE DEVICES AND BARRIERS

The use of APD is recommended in all 250cc speedway events.

### 079.4.1 Safety barriers for natural and artificial Ice tracks

The track must be surrounded by up to 3 barriers:

#### Barrier 1

A spectator barrier must be provided, at least 2 m high, prohibiting public access to the neutral zone. The stanchions must not protrude above the top of the barrier and all sharp edges must be covered. This barrier may be dispensed with if the distance from the bends to the public zone is large enough, as shown in the track inspection report.

#### Barrier 2

A barrier at least 1.2 m high, and (+/-) 1.5 m wide, made of snow or formed by bales must be erected in front of barrier 1. Bales (straw or plastic material) must be suitably covered and retained in place by a rope type system that will allow them to give slightly under impact.

#### Barrier 3

A barrier at least 80 cm high is erected about 1 m or more in front of barrier 2. It can be composed of bales (straw or plastic material) suitably covered, and must be free standing in order to be able to slide under impact.

### 079.4.2 Safety barriers for Speedway, Long & Grass tracks

A safety fence must be constructed to prevent damage or injury to a rider, an official, a spectator or any other person.

A vertical safety fence must surround the track and be of a minimum height of 1.2 m.

A shock absorbing type of fence is recommended.

The safety fence can be constructed with wooden planks, board material, plastics, rubber, wire-mesh or other protective approved material. However it must be constructed in order to absorb kinetic energy if a rider crashes into it.

### 079.4.3 Wooden fence

A fence built with wooden planks must be a minimum of 20 mm and a maximum of 25 mm in thickness. A fence built with plywood board or laminated wood must be a minimum of 16 mm and a maximum of 25 mm in thickness. It should be properly proofed against rot or other deterioration. If wooden planks are used, they must be erected vertically.

The fence must be supported on the outside by suitable stanchions, which are firmly fixed in the ground. The stanchions must not protrude above the top of the fence.

The inside surface of the whole fence must be painted in order to contrast clearly with the colour of the track surface.

Throughout its entire length, the top of a wooden fence or any other approved board material must be equipped with a securely fixed, smooth, rounded cap.

### 079.4.4 Wire mesh fence

If the fence is a wire-mesh construction, the wire must be made in steel and have a minimum diameter of 2,5 mm. The width between the mesh must not exceed 50 mm. The wire mesh must be carried on the outside by suitable stanchions, which are firmly fixed in the ground. The stanchions must not protrude above the top of the mesh. An exception is the suspended wire-mesh fence.

Each stanchion must be equipped with one or more coil springs to which the wire mesh is attached. Alternatively, polystyrene, phenol-formaldehyde foam or similar approved crushable material, which will compress and absorb kinetic energy on impact, may be employed instead of springs. Such material must extend the full exposed length of each stanchion.

The mesh must be supported by three horizontal strain wires of a minimum diameter of 6 mm.

The upper wire must be located at the top of the mesh, and second wire approximately 50 cm from the top. The third wire must be located at the bottom. The wires must be securely attached to the stanchions and must go through the net at the top and the bottom of the net at the full length of the wires and not mounted with plastic cable ties. Strain wires must be kept taut at all times.

For wire-mesh fences, the capping must be made of strong canvas, rubber, plastic or similar flexible material and extend at least 5 cm down both sides of the mesh. The capping must be securely fastened.

Inside the net, it is recommended to have a cover in suitable material overlapping the top of the fence and reaching down under the kick-board.

#### **079.4.5 Safety barriers on temporary tracks**

Alternatives to the wood or wire mesh fence, where authorised, are described below:

##### Alternative I

Straw bales of at least 80 cm in height are placed side by side without spacing around the track. The bales are secured in position by roping or like manner to ensure that they cannot be knocked onto the track. Outside the bales a catching net of a wire mesh construction, not less than 1 m in height, is erected at a distance of not less than 3 m. If space permits, the widths of the neutral zone should be substantially wider than the minimum specified, or an additional neutral zone should be provided.

##### Alternative II

The outer edge of the track is marked by a continuous white line or by very small flags and, outside this outer edge, there will be a run-off zone. The width of this run-off zone must be at least 1% of the track length but not less than 4 m.

- a) If these conditions are met, the safety fence may be 1,10 m high and without a kick board. Outside, and adjacent to the safety fence, there must be a neutral zone with a suitable barrier to deny access to the zone by the public. The width of the neutral zone must be a minimum of 2 m when the run-off zone is between 4 m and 6 m in width and 1 m in width when the run-off zone is over 6 m in width.
- b) The run-off zone is surrounded by rope-and-stake wrecking fences, two on the straights and three on the bends, with neutral zones between them; the height of the wrecking rope from the ground should be approximately 75 cm; the width of the neutral zone on the straights should be not less than 2 m, and of the neutral zones on the bends not less than 3 m.

For sidecar racing, there should be four wrecking fences on the bends.

At 3 m from the outside of the outer wrecking fence, a wire mesh barrier should be provided in order to deny access of the public to the neutral zones.

Obstacles, except those that are necessary for the organisation of the meeting, are not permitted in neutral zones.

#### 079.4.6 Additional Protective Devices

Additional Protective Devices (APD) require as from 01.01.2007 an official homologation pursuant to the standards, procedures and specifications for the CCP/FIM Test for APD.

The Homologation is valid only for the tested model/product. New models/products must undergo and obtain a new homologation in accordance with the relevant tests. APD successfully used in FIM World Championship meetings before 2007 can still be used without homologation until 31.12.2010, with the express approval from the CCP/FIM.

If an APD is used permanently or temporarily, it must be erected against a secondary fence on the bends and first part of the two straights only. The secondary fence must be approved by the FIM. There should be no free space between the APD and the secondary fence.

The height of the APD shall not be less than 1.2 m. The APD must be solidly connected to the top and, as solidly as possible, to the bottom of the secondary fence or to the ground in order to avoid a possible rising during impact.

The lower part of each APD must be equipped with a kick board approximately 30 cm high according to Art. 079.4.7.

If constructed by the means of modules, these shall be solidly attached and a flap, overlapping and connected to the next module in the direction of racing, has to be provided at the end of each module. The same applies for the kick board.

All the materials composing the APD must be fire resistant.

Contingency ADP must be available in order to be able to quickly replace a punctured or damaged unit.

The co-ordinates of the manufacturers and distributors of homologated Additional Protective Devices are listed in Appendix A.

The following Track Racing Additional Protective Devices are homologated (see manufacturers' and/or distributors' co-ordinates in Appendix A):

Type A (Long Track, Grass Track and Speedway)

- Tony Briggs "No Pain Barrier", "Catching Air", "Air Net"
- ADMAR Speedway Air Barrier
- VIV1 "Safety4all Plus"
- FUN4SALE.PL "Safety4all"
- TENT GRUPA "Banda Pneumatyczna Ochronna", "Safe Speedway Barrier"
- **SIDIJK BV "Sidijk Impact Protection System"**

Type B (Speedway)

- Airfence Safety Systems (Australia) "Airfence Speedway", "Airfence Speedway Inflatable".
- **PROTAN LESJÖFORS AB "ProFence"**

#### **079.4.6.1 Homologation procedure of new Additional Protective Devices**

The test procedure as well as the appointed laboratories can be obtained from the FIM Executive Secretariat.

Performance tests must be carried out in a laboratory by the applicant. The laboratory must have obtained the ISO17025 certification. The applicant must provide an official document attesting that the laboratory fulfils this request as well as a recent document certifying the calibration of the instruments. The CCP/FIM has the right to appoint an inspector at these tests. Requests must be made to the FIM Executive Secretariat at least 3 months before the tests are due to be carried out.

To obtain the homologation, the applicant must submit to the FIM Executive Secretariat:

- Pictures of the module showing in detail the overlapping of the kick board and the flap connecting one module to the other
- The video recording of the tests performed in the laboratory
- Copies of the report of these tests
- The video recording of the fire resistance exercise approved by a recognised laboratory.

#### **079.4.7 Kick board**

The lower part of the safety fence must be equipped with a kick board, approximately 30 cm height. It must be constructed in such a manner that it will prevent damage to riders and equipment. At the same time it shall connect up the sections of the safety fence. For some type of fence the kick board may not be necessary. Special permission can only be given by the CCP Executive Secretariat.

The sections of the kick board must be overlaid in the direction of racing and painted in order to contrast with the colour of the track surface. For temporary tracks, kick boards are not required on the safety barriers.

The use of a hard, rubber type compound is recommended for the construction of a kick board.

#### **079.4.8 Access gates**

The number of access gates in the safety fence must be the minimum necessary for the efficient organisation of the meeting. Preferably, no gate should be located at any part of the track where riders may be expected to ride into the fence.

Gate stanchions must not be higher than the height of the fence, and be covered in an approved manner with crushable material. Hinges and locks must be fitted on the outside of the stanchions and gate frames (in relation to the track).

In any type of fence, the slot for the starting gate should not be wider than necessary for providing operating clearance. The slot must terminate at least 30 cm above the track surface, and the kick board must be continuous below the slot.

#### **079.4.9 Neutral zone**

##### Speedway tracks:

The width of the neutral zone should not be less than 2 m, with a suitable barrier to deny access to the zone by the public.

### Long & Grass tracks:

The width of the neutral zone should not be less than 2 m in the straights and 3 m in the bends, with a suitable barrier to deny access to the zone by the public.

### Temporary tracks:

There must be a neutral zone on the outside of the safety fence or barrier. This neutral zone must be at least 2 m in width on the straights and 3 m in width in the bends, with a suitable barrier to deny access to the zone by the public.

Obstacles, are not permitted unless necessary to serve the organisation of the meeting. Any lighting posts or other obstacles that could cause damage or injury situated in the neutral zone, within 2 or 3 m minimum distance from the fence must be adequately covered with straw bales or cushioning material at least 60 cm in width and 2 m in height towards the direction of racing.

## **079.5 MARKING**

The inside and outer edges of the track must be clearly marked.

### **079.5.1 Marking of the outer edge**

If there is no safety fence on the outer-edge of the track, the outer-edge must be marked by a continued white line or by small flags. The racing track must also be surrounded by a run off zone.

The public must be safely protected from the racing by a suitable barrier of rope, net or a similar protective material.

### **079.5.2 Marking of the inside edge**

#### Speedway, Long & Grass tracks:

The inside edge must be kept visible throughout the meeting, and marked by a continuous line of a colour that contrasts with the track surface. The line may be indicated by means of white powder or whitewash, not less than 15 cm wide, or by a wood or concrete kerb painted in contrast to the surface and not less than 5 cm wide. A kerb must not protrude above the surface by more than 5 cm and must enable a motorcycle to ride over it safely in an emergency situation. The inside edge may also be indicated by very small flags and, preferably, placed 1 m inside a white inner edge line.

### Ice tracks:

The inside edge must be kept visible throughout the meeting and marked by a continuous line in a bright, contrasting colour (such as red or blue) not less than 15 cm wide. The line, marking the inside of the track in the bends, must not be painted nearer than 15 cm to the edge of the track.

## **079.6      INFIELD AND ADVERTISING**

### **079.6.1      Infield**

The infield must be in the same plane as the track and approximately level so that a rider may safely ride on it, should he be forced off the track.

In exceptional circumstances, obstacles, which cannot be removed, may be permitted providing that they are not closer than 4 m to the inner edge of the track. These obstacles must be amply covered with straw bales, polystyrene, phenol formaldehyde or similar crushable material to a minimum height of 2 m from the ground level.

For tracks exceeding 700 m in length, the clerk of the course and the doctor may have a vehicle at their disposal, on the infield, for quick transport to any part of the track in case of an emergency. In addition, an ambulance may be stationed on the infield if the doctor decides this precaution is desirable.

Otherwise, vehicles which may be required for use from time to time, such as water tankers, tractors and graders, must be accommodated outside the circuit when not in use, whenever possible.

### **079.6.2      Advertising**

The only acceptable obstacles permitted in the infield are portable advertising boards and structures that are necessary for the organisation of the meeting. Portable advertising boards shall not exceed 1 m high, and must either be inflatable or constructed of light materials such as plywood, polystyrene, thin metal or plastic sheets mounted on light weight frames so that they can collapse easily if struck. They must be placed more than 4 m from the inner edge of the track and be inclined towards the direction of racing.

Any banner, poster or other display on the inside of a board fence is only permitted if it is painted on the fence or it must be completely secured by adhesive.

## 079.7 TRACK INSTALLATIONS

### 079.7.1 Starting area

According to the number of starters, the starting area must be divided into equal parts by longitudinal lines of 5 cm width. These lines, on the track surface, are extending back for 1 m from the starting line.

For Long Track: the minimum distance between the lines is 1.5 m for solos and 2.5 m for sidecars

For Grass Track: the minimum distance between the lines is 2 m for solos and 3 m for sidecars

All lines in the starting area must be marked with powder that contrasts with the colour of the track surface, and must be renewed after each race.

On Ice tracks the lines must be marked in a bright contrasting colour (such as red or blue) and maintained visible throughout the meeting.

All markings in the starting area must be clearly visible to the Referee at all times throughout the meeting.

### 079.7.2 Starting line

A continuous, straight starting line (which serves, also, as the finishing line), at least 5 cm wide, must be marked across the full width of the track at a right angle to the inner edge.

#### Speedway and Ice tracks:

The starting line should be positioned in the middle of the straight, and if this is not possible then not less than 35 m from the entrance to the first bend.

#### Long & Grass tracks:

The starting line should be positioned in the middle of the straight, or if this is not possible then not less than 2/5 of the length of the straight before the first bend.

### 079.7.3 Starting gate

Vertical stanchions, approximately 3 m in height, must be securely mounted one on the infield and the other outside the safety fence. On the infield it should be placed approximately 1 m from the inner edge line and should be covered in an approved manner with straw bales or cushioning material at least 60 cm in width and 2 m in height towards the direction of racing.

Each stanchion must be equipped with 2 sliders, to carry the tapes, with a slider stop at a height of approximately 2.9 m and with a pulley at the top for the elastic cord which raises the slider when it is released.

A solenoid-and-pawl, an electro magnet or similar mechanism must retain the slider when it is in the lower position to give the required height of 53 cm for the bottom tape. Two or three tapes must be attached to the sliders of the starting gate with rubber bands at each end which, when not stretched, are no longer than 15 cm and not wider than 2.5 cm.

Metal clips, hooks or other forms of metal connections must not be attached to the tapes or bands.

The tapes must be made of an easy breakable material.

The tapes must be of a contrasting colour with the colour of the track surface. For Ice tracks they should be preferably red or blue.

The gate releasing mechanism must only be controlled from the switchboard.

Should a starting gate fail to operate properly, the green light or a flag may be used for signalling starts.

#### 079.7.4 Signalling

Signals to riders must be given by means of either lights or flags. The size of signalling flags must be of 60x60 cm minimum.

Green light or national flag:	Start
Flashing red light + siren or red flag + siren:	All riders stop
Yellow flag with diagonal black stripes 5 cm wide:	Last lap
Black and white chequered flag:	Finish
Horn, siren or bell audible in the pits and near the starting line together with flashing amber light:	Final warning of limited time for riders to reach the start line.
Black flag and light indicating rider's colour, or black flag with a disc of a diameter of at least 45 cm indicating the rider's colour	Rider disqualified

#### 079.7.5 Light signals

A green starting light shall be provided at least 10 m in front of the starting line, clearly visible to the riders and in direction of the racing. For Long & Grass tracks, this green starting light and a red stop light must be positioned max. 30 m in front of the starting line and about 2 meters above the track level.

A supplementary green light, operated in conjunction with the green starting light must be located 10 m in the rear of the starting line, and be easily visible to the starting marshal when he is facing the direction of racing.

The disqualification lights shall consist of a group of four to eight lights corresponding to the riders' helmet colours (red, blue, white, yellow & black, green, black & white, red & white, blue & white). They must preferably be assembled in a vertical tower and visible to any part of the stadium. All lamps must be of high intensity type.

Two flashing amber lights, each one operating in conjunction with the 2 or 3 minute horn, siren or bell, must be placed as follows:

- a) one in the pits, clearly visible to all riders
- b) one near the starting gate

In addition to these lights there must be a minimum of three red, flashing lights, positioned not more than 4 metres from the track and easily visible by the riders, three marshals with red flags placed at intervals on each bend of the track and a siren that operates with the lights.

All lights must be of high intensity type and be easily visible to the riders.

The lights must be located at least 60 cm outside the safety fence or barrier, but not more than 4 m away.

If mounted on the stanchions inside the neutral zone, the stanchions must incorporate a pivot at a height of not more than 30 cm from track level, so that, if it is struck by a rider or machine, the upper part of the stanchion will easily collapse in the direction of racing.

#### **079.7.6 Referee's box**

An observation box, placed adjacent to the starting area, must be provided for the Referee. This box must be sufficiently high in order to give the Referee an unhindered, overall view of the track and the starting area.

This accommodation must have an adequate roof in order to protect the Referee in case of wet weather. The Referee's box must be located on the outside of the track so that the Referee can align himself with the starting line.

The box must be located outside the neutral zone or zones and be equipped with a switchboard for operating the starting gate, the signal lamps and the warning horn, siren or bell. The Referee's box must have a proper telephone installation for communication with the starting marshal, the pits' marshal, the announcer and provide ample facilities for writing.

The switchboard should be equipped with easily understandable indicators for the functioning of the switches. The wiring must ensure that:

- a) The 2 flashing amber lights will automatically switch off when the green starting lamp (and its subsidiary lamp) has been switched on.
- b) The switch to raise the starting gate will not operate until the green starting lamp (and its subsidiary lamp) has been switched on.

- c) The green starting lamp (and its subsidiary lamp) will automatically switch off ten seconds after the starting gate has been released.
- d) Possibility to switch off the green light without releasing the tapes.

It is compulsory to have a digital stop watch in the Referee's switchboard. The stop watch should operate in conjunction with some of the switchboard buttons as follows:

Pressing the flashing amber light button:	watch reset and start
Pressing the green light button:	watch reset and start
Pressing the starting gate button:	watch reset and start

At tracks where racing is held under artificial lighting, an adequate lamp which can be switched on and off by the Referee, must be provided in the Referee's box.

The switches for operating the disqualification lights in Speedway and Ice races must be placed in the following order: Red, blue, white and yellow & black and, additionally for Long & Grass track (where applicable) green, black & white, red & white and blue & white.

#### **079.7.7 Pits**

Each rider must be provided with a minimum of 8 m<sup>2</sup> of space on hard ground.

At all tracks, covered accommodation must be provided to give protection in case of bad weather.

Drinking water and washing facilities must be provided throughout the meeting.

There must be a minimum of one toilet reserved for riders, and placed nearby the pits.

Facilities for collection of rubbish, oil and tyres must be available in the pits.

#### **079.7.8 Changing room**

Sufficient enclosed accommodation for at least 20 persons must be provided within the pits area or nearby.

These facilities must include toilets, water supplies, showers and seating.

### **079.7.9 Washing of motorcycles**

Washing of motorcycles at the venue must be carried out at places with washing facilities only. Cleaning (wiping with detergents, for example) or rinsing with pure water (without the addition of any chemical products), is permitted and cleaning must be carried out in accordance with the Environmental Code and on the following conditions:

- a) That a non-porous wash area has been provided, complete with a drain and a separate oil collector.

Or,

- b) That a pond, lined with a waterproof membrane, is provided with sufficient capacity to contain all the waste arising from motorcycle washing, and the contents are removed by a vacuum tanker for disposal in accordance with local regulations.

## **079.8 EMERGENCY SERVICE**

### **079.8.1 Medical service**

During the official practice and the meeting, at least one suitably qualified doctor, ambulances (one on practice day and two on race day), and sufficient medical staff with first-aid kits and stretchers must be in attendance.

Medical staff with first-aid kits and a stretcher must be stationed on the infield, in the middle of each bend, and well away from the edge of the track.

The exact whereabouts of the doctor throughout the practice and the meeting must be known by the Clerk of the Course.

### **079.8.2 First-aid room**

At least one bed, hot water supplies and adequate medical stores must be provided in a room or tent from which non-medical staff can be excluded.

The first-aid room will be under the responsibility of the medical officer in charge.

### 079.8.3 Fire-fighting equipment & emergency tools

**The fire extinguishers' minimum standard must be: 5 litres / type AB or ABC / Dry powder extinguishers.**

At least four fire extinguishers, which have been checked for proper working order before the practice and before the meeting, must be located on the infield or near the starting area.

Two similar fire extinguishers must be entrusted to the pits marshal.

**Two similar fire extinguishers must be placed in the refuelling area.**

Tools and spare parts for fast repair of any part of a safety fence must be available.

### 079.8.4 Fuel

#### Provision of fuel

Fuel may only be provided from a point a minimum of 7 metres from any other vehicle. The area must be secured, and the supplier must display "no smoking" and "no naked light" signs. In addition the supplier must comply with appropriate local regulations.

## 079.9 PRESS FACILITIES

The following minimum facilities for the Press must be provided in 1 workroom with tables, chairs and typewriters:

- 1 fax machine with direct lines
- 1 telephone with direct lines
- 1 photocopy machine
- Internet connection

Telephone communications may be charged to the journalists. The only persons authorised in this room are the media (TV, journalists, photographers) and FIM/FMN Officials.

It is recommended to provide the press with free drinks and a small buffet.

**079.10 FIM SPEEDWAY WORLD CHAMPIONSHIP GRAND PRIX  
& FIM SPEEDWAY WORLD CUP**

The rules of the present Appendix apply for all tracks used for the FIM Speedway World Championship Grand Prix and the FIM Speedway World Cup, except where different or added to by Regulation 077 "FIM Speedway World Championship Grand Prix Rules" and Regulation 078 "FIM Speedway World Cup".

# TRACK INSPECTION REPORT

Name of track: \_\_\_\_\_ Type of track: \_\_\_\_\_

Location: \_\_\_\_\_ Country: \_\_\_\_\_

Last Inspection: \_\_\_\_\_ Licence N°: \_\_\_\_\_ Validity: \_\_\_\_\_

## **DIMENSIONS:**

Length of the Track: \_\_\_\_\_ Width of Straights: \_\_\_\_\_

Width of Bends: \_\_\_\_\_ Radius: \_\_\_\_\_

Bends of similar shape: \_\_\_\_\_ As near as possible: \_\_\_\_\_

Type of Marking the Inner Edge (art. 079.5.2): \_\_\_\_\_

## **SURFACING:**

Material Used in Track Sub-soil: \_\_\_\_\_

Material Used for the Surface: \_\_\_\_\_

Depth: \_\_\_\_\_ mm Granulation: \_\_\_\_\_ Surface smooth: \_\_\_\_\_

No Toxic Material: \_\_\_\_\_ Drainage: \_\_\_\_\_

## **FENCE CONSTRUCTION:**

Height: \_\_\_\_\_ cm Kickboard: \_\_\_\_\_ cm

Top capping: \_\_\_\_\_

Wooden plank: \_\_\_\_\_ Board: \_\_\_\_\_ Wire mesh: \_\_\_\_\_

Minimum slot for tapes: \_\_\_\_\_ Boards painted: \_\_\_\_\_

No banners: \_\_\_\_\_ Distance from fence to outer edge: \_\_\_\_\_

## **INFIELD:**

Height edge: \_\_\_\_\_ mm No obstacles: \_\_\_\_\_

If yes - what?: \_\_\_\_\_

Covered: \_\_\_\_\_ Collapsible: \_\_\_\_\_

## **STARTING GATE:**

Location on straight as per art. 079.7.2: \_\_\_\_\_

Construction: \_\_\_\_\_ Functioning: \_\_\_\_\_

Marking of starting line: \_\_\_\_\_

**SIGNALLING:**

Green light: \_\_\_\_\_ Disqualification lights: \_\_\_\_\_ Number: \_\_\_\_\_  
 Disqualification flags/discs: \_\_\_\_\_ Number: \_\_\_\_\_  
 Stop lights: Placing: \_\_\_\_\_ Flexible Stanchions: \_\_\_\_\_  
 Two minutes warning: Placing: \_\_\_\_\_ Siren: \_\_\_\_\_

**NEUTRAL ZONE:**

Distance to public barrier: \_\_\_\_\_ m Obstacles (if any): \_\_\_\_\_  
 If yes - what?: \_\_\_\_\_

**REFEREE'S FACILITIES:**

Referee's box: Position: \_\_\_\_\_ Visibility: \_\_\_\_\_  
 Switchboard: \_\_\_\_\_  
 Co-ordination green light / starting gate: \_\_\_\_\_  
 Co-ordination green light / amber light: \_\_\_\_\_  
 Automatic switch-off of the green light after 10 sec.: \_\_\_\_\_  
 Telephone connection to pits/start/speaker: \_\_\_\_\_

**PITS:**

Dimension: \_\_\_\_\_ m<sup>2</sup> Hard ground: \_\_\_\_\_  
 Covered: \_\_\_\_\_ Changing room: \_\_\_\_\_  
 Facilities (showers, toilets, etc...): \_\_\_\_\_

**PITS ENVIRONMENT:**

Facilities for washing motorcycles: \_\_\_\_\_  
 Facilities for oil/fuel collection: \_\_\_\_\_  
 Facilities for rubbish collection: \_\_\_\_\_  
 Facilities for fuel storage: \_\_\_\_\_  
 Facilities for fuel filling: \_\_\_\_\_  
 Does the design and construction of the pits protect the natural ground, in accordance with the CIE requirements: \_\_\_\_\_

**FIRST AID:**

First Aid room as per art. 079.8.2: \_\_\_\_\_  
 Approach for ambulances to the track: \_\_\_\_\_  
 Distance to the nearest hospital: \_\_\_\_\_  
 Type of specialisation which is provided: \_\_\_\_\_  
 Fire extinguishers and tools: \_\_\_\_\_

**VEHICLES:**

Parking place for ambulances: \_\_\_\_\_

Supply of water for watering the track: \_\_\_\_\_

Roller available: \_\_\_\_\_ Grader available: \_\_\_\_\_

Other Equipment Available: \_\_\_\_\_

**LIGHTS, SOUND AND POWER SUPPLY:**

Place of light posts: \_\_\_\_\_ Number of light posts: \_\_\_\_\_

Light output in kilowatts: \_\_\_\_\_ kW

Light intensity on the track: \_\_\_\_\_ Lux

Light intensity in the pits: \_\_\_\_\_ Lux

Loudspeakers: \_\_\_\_\_ Number: \_\_\_\_\_

Maximum power supply capacity of the stadium in kilowatts: \_\_\_\_\_ kW

**TV BROADCASTING:**

Parking area for TV broadcasting trucks: \_\_\_\_\_

Power supply for TV: \_\_\_\_\_

**GENERAL INFORMATION:**

International Jury facilities:

Size of Jury office: \_\_\_\_\_ Accommodation: \_\_\_\_\_

Furnishing: \_\_\_\_\_ Installation – computer: \_\_\_\_\_

Tél./Fax: \_\_\_\_\_ Internet: \_\_\_\_\_ Other: \_\_\_\_\_

Track facilities:

Seating capacity of stands: \_\_\_\_\_

Standing capacity of stands: \_\_\_\_\_ Entrances: \_\_\_\_\_

Exits: \_\_\_\_\_ Car Parking capacity: \_\_\_\_\_

**REMARKS AND OTHER DETAILS:**

---



---



---



---

**INSPECTOR'S RECOMMENDATION:**

Track is acceptable for meetings with 6 riders: \_\_\_\_\_

Licences should be issued for: 3 years: \_\_\_\_\_ 1 year: \_\_\_\_\_

Track requires inspection: by the FMNR: \_\_\_\_\_ by the FIM: \_\_\_\_\_

Date: \_\_\_\_\_

FIM Representative's name & signature: \_\_\_\_\_

FMN Representative's name & signature: \_\_\_\_\_

Club Representative's name & signature: \_\_\_\_\_

The appointed track inspector must complete the track inspection report by computer and send it by e-mail to the FIM Executive Secretariat and FMN concerned within a few days of the track inspection. The original signed document must be sent by mail afterwards to the FIM Executive Secretariat with copies to the FMN and the Club concerned.

TRACK MEASUREMENTS - SPEEDWAY

(Radius of bends to length of straights - metres)

Examples but not compulsory

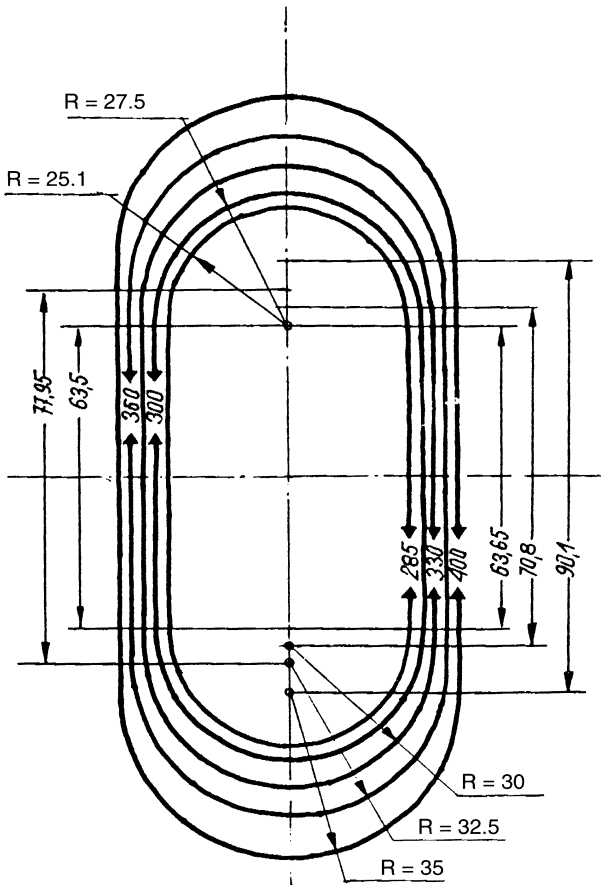

Illustrations / Drawings

TRACK MEASUREMENTS - LONGTRACKS AND GRASSTRACKS

(Radius of bends to length of straights - metres)

Examples but not compulsory

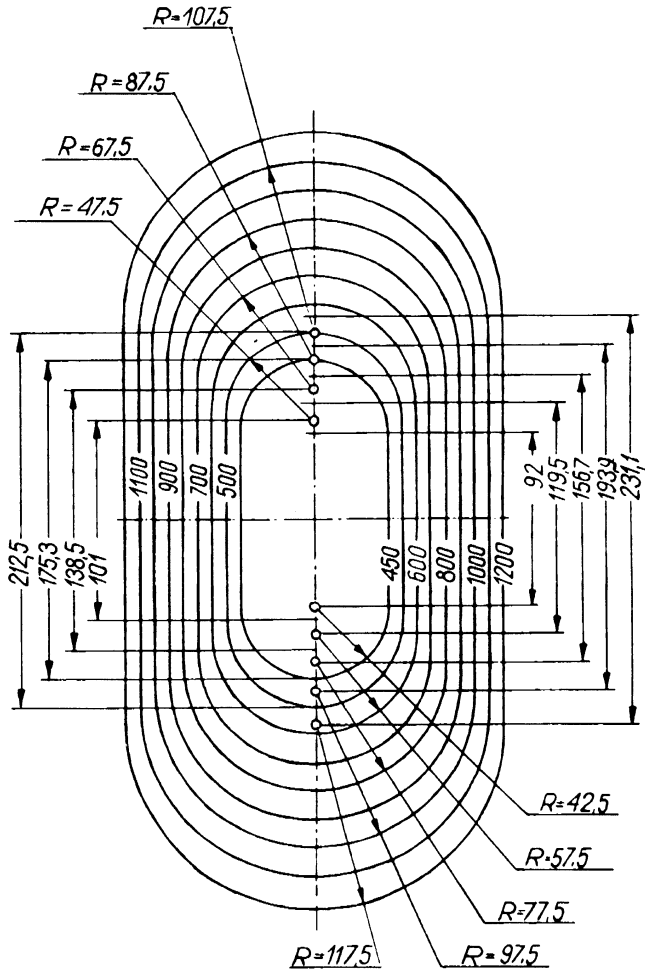

GRADING AND WATERING OF THE TRACK

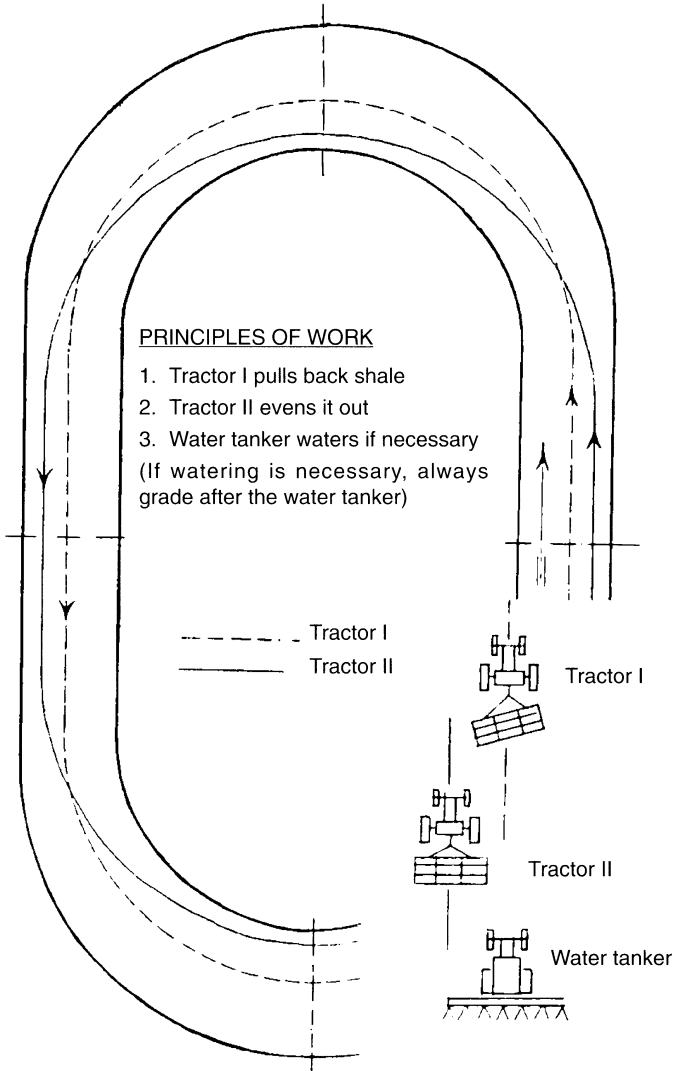

EXAMPLES  
EQUIPMENT FOR PROPER TRACK MAINTENANCE

CONSTRUCTION OF GRADER

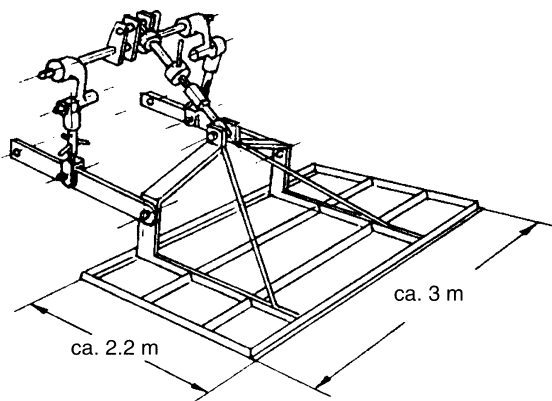

FIXING TO THE TRACTOR

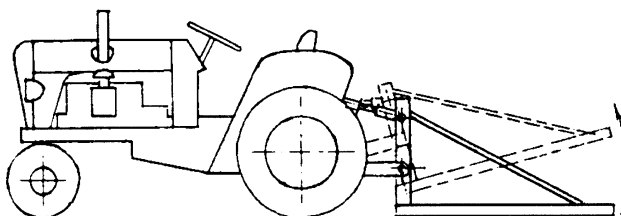

### TRACK MAINTENANCE

NOT SO:

Grading after each 4th heat or less



Track before racing



Track after first race



Track after second race



Track after third race



Track after fourth race

Result: Track foundation ruined.  
Racing poor and safety jeopardize!

BUT SO:

Grading after each heat



Track before racing



Track after first race



Track before second race



Track after second race



Track before third race

EXAMPLES OF  
EQUIPMENT FOR PROPER TRACK MAINTENANCE

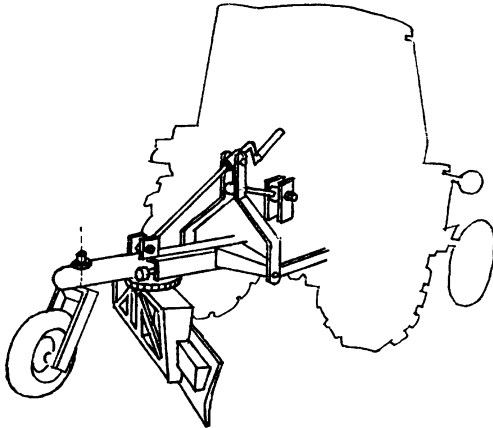

GRADER FOR RESTORATION OF LEVEL OF SUB-SOIL

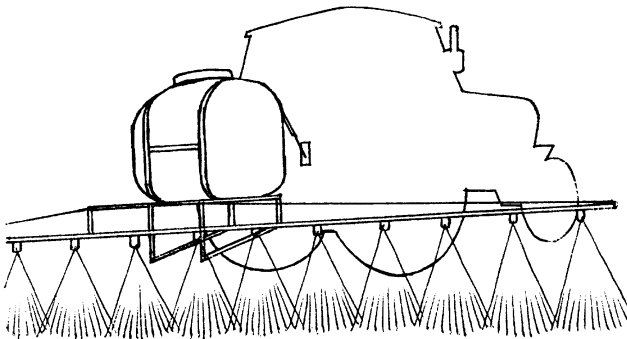

FARMING EQUIPMENT FOR WATERING BETWEEN HEATS

## SAFETY BARRIERS FOR ICE TRACKS

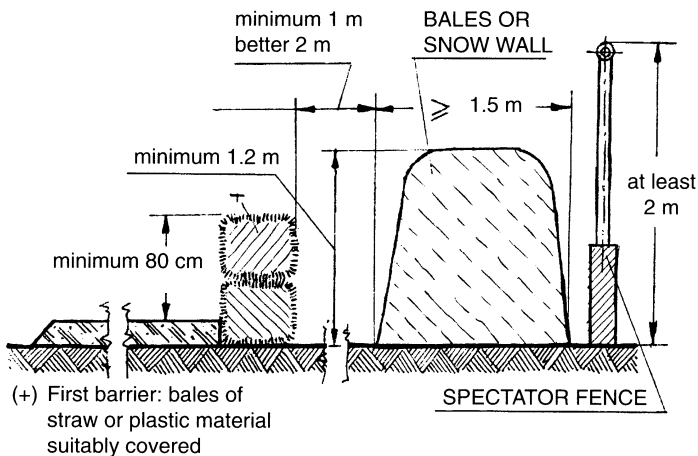

## MARKING OF THE INSIDE EDGE OF THE BENDS ON THE ICE-TRACKS

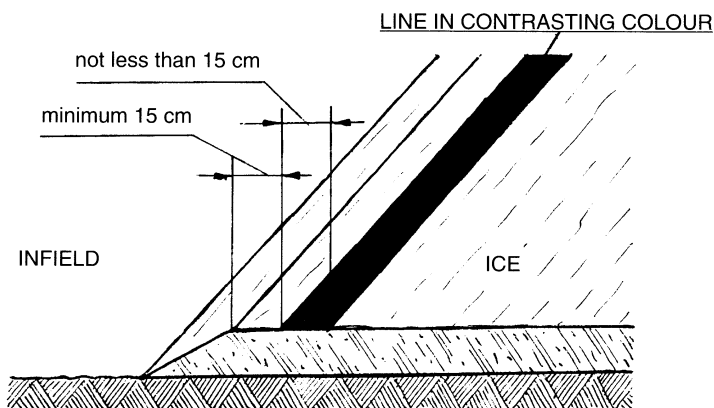

THE FENCE - OF WOODEN BOARD

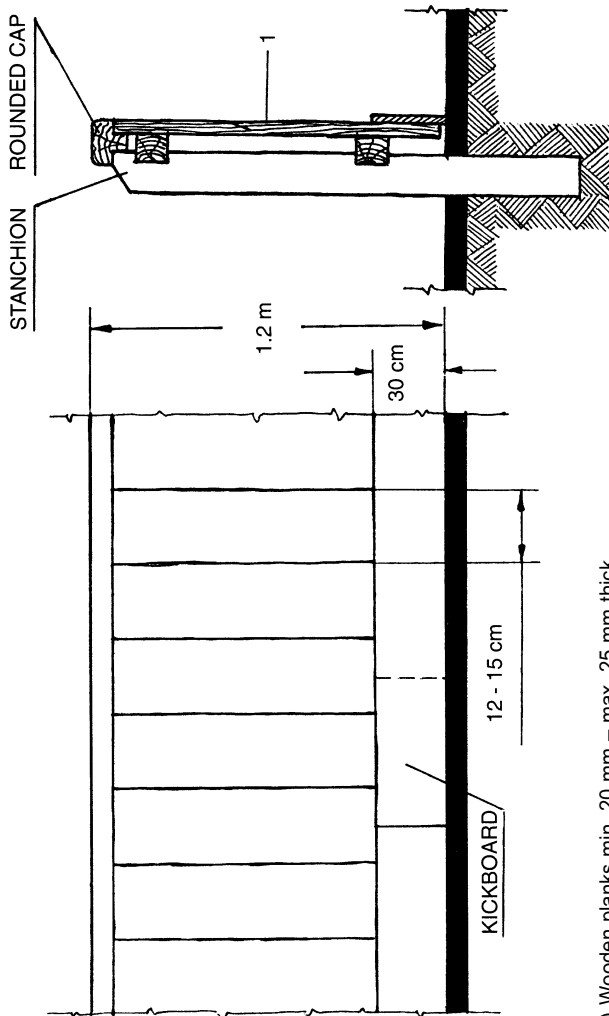

1) Wooden planks min. 20 mm – max. 25 mm thick

THE FENCE - OF BOARD OF PLYWOOD CONSTRUCTION

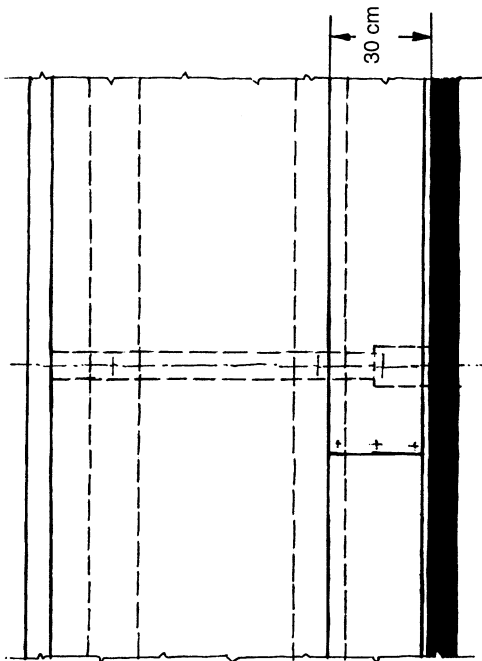
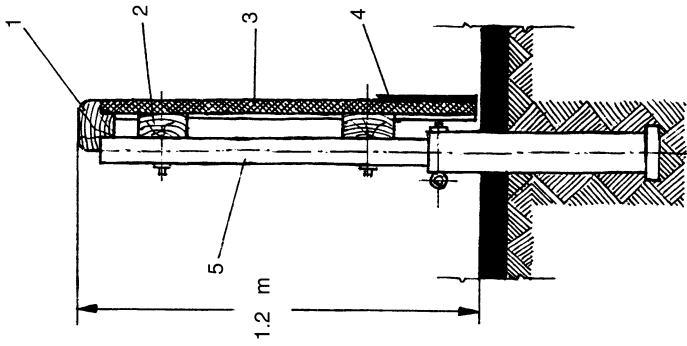

- 1) Impregnated wood 2.5 – 7.5 cm
- 2) Impregnated beam 5.0 – 10 cm
- 3) Plywood board or laminated wood 120 cm x 240 cm, min. 16 mm and max. 25 mm thick
- 4) Impregnated plank (30 cm x 22 mm minimum) or kick board according to Art. 079.4.6
- 5) Steel tubing  $\varnothing$  77 mm

THE WIRE-MESH FENCE

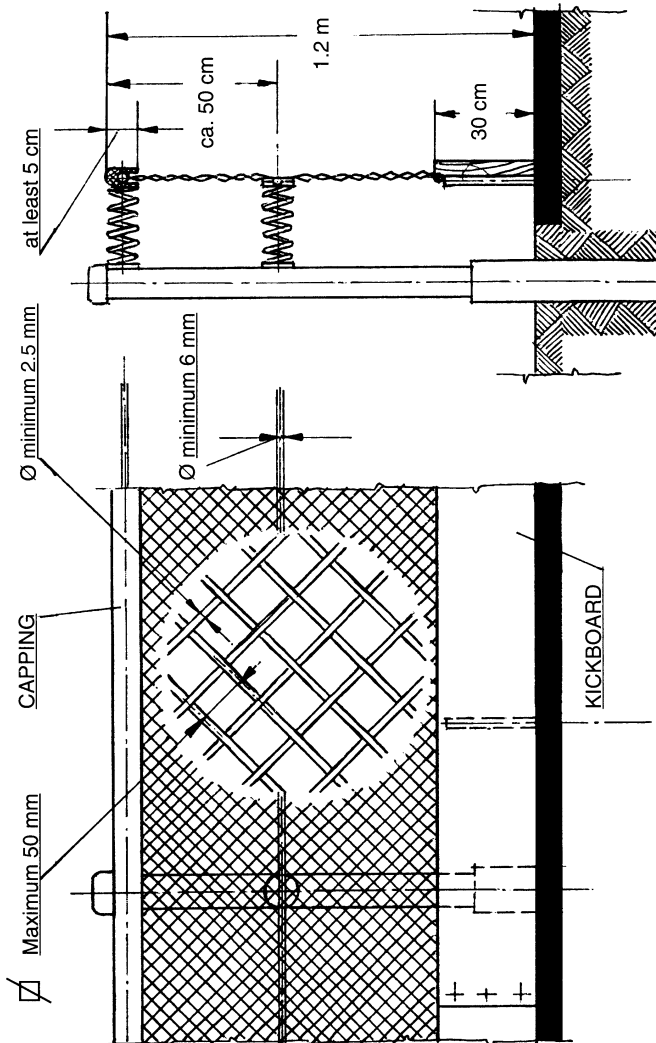

THE FENCE - OF WIRE-MESH CONSTRUCTION  
(Stanchion protected)

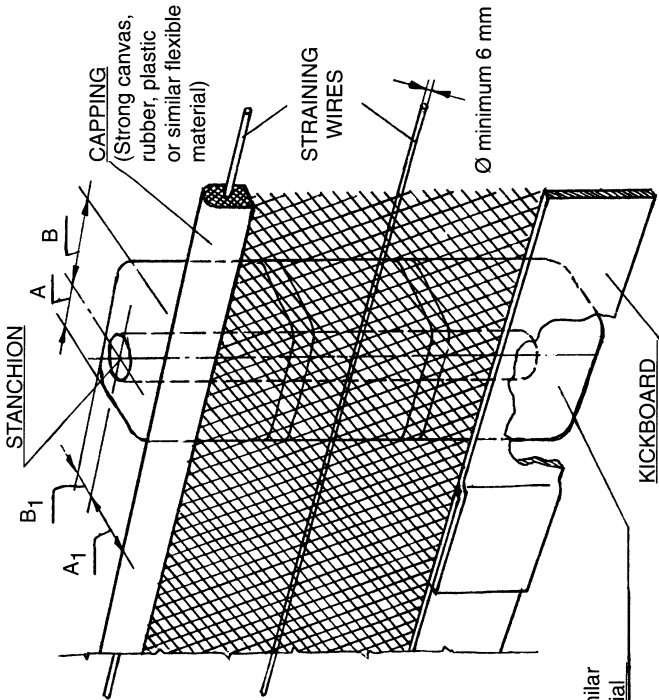

$A < B$   
 $A_1 > B_1$

Polystyrene, phenol-formaldehyde foam or similar approved crushable material

WIRE-MESH FENCE (SUSPENDED)

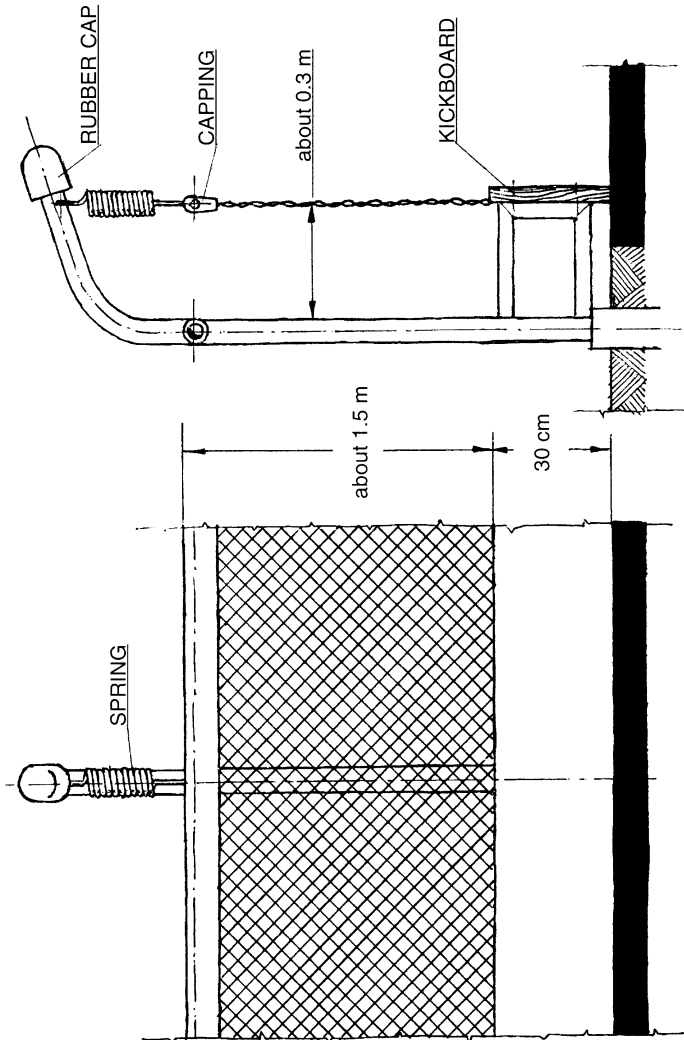

COVERING OF OBSTACLES ON INSIDE AND OUTSIDE OF FENCE

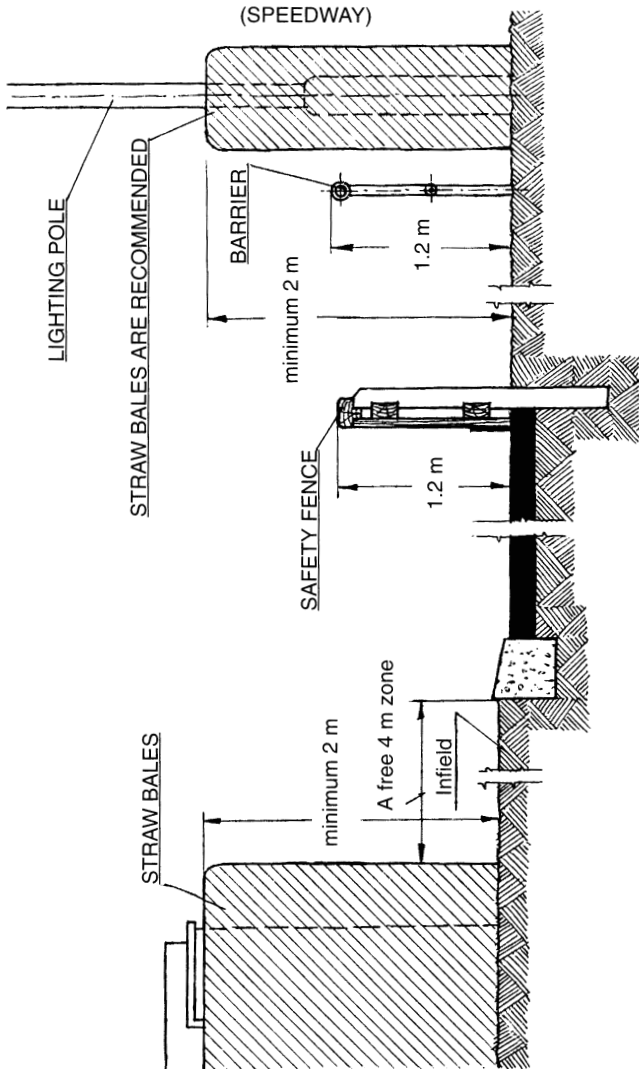

DANGEROUS PARTS OF THE FENCE

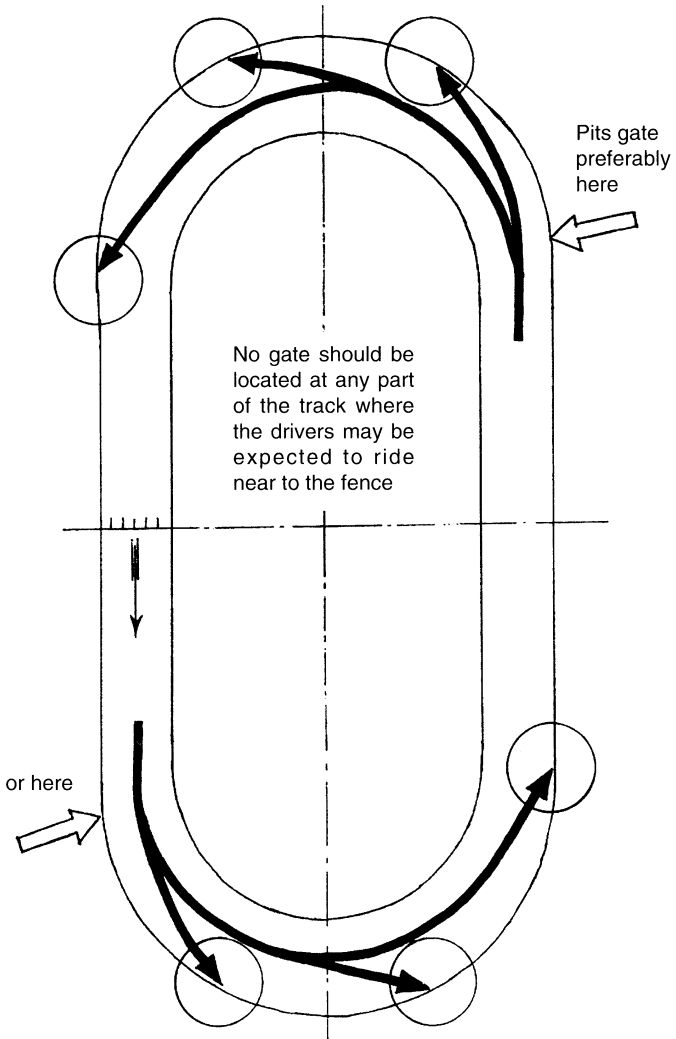

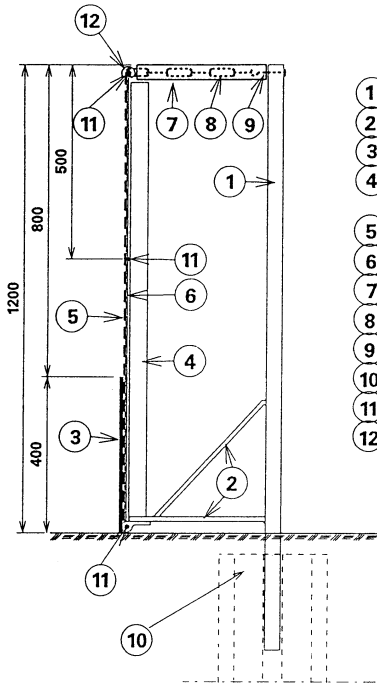

- ① GALVANIZED POST 40x40x4
- ② BOTTOM WIRE HOLDER
- ③ KICKBOARD 400
- ④ UPPER WIRE SUPPORT WOOD 45x45
- ⑤ COVER
- ⑥ NET 50x3
- ⑦ RUBBER HOSE
- ⑧ CHAIN 3/8
- ⑨ STRAIN BOLT
- ⑩ POST FOUNDATION
- ⑪ WIRE  $\phi$  6
- ⑫ TOP CAPPING

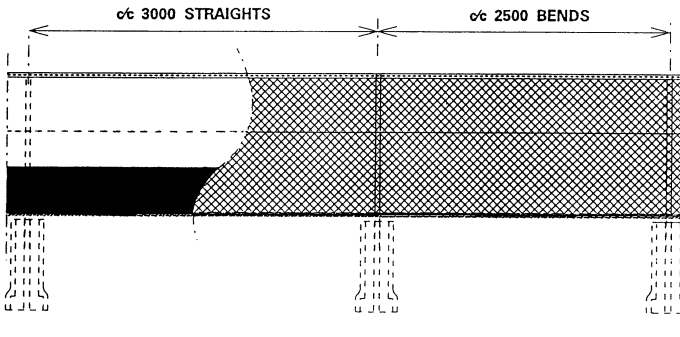

OPENING IN THE FENCE FOR THE STARTING MACHINE

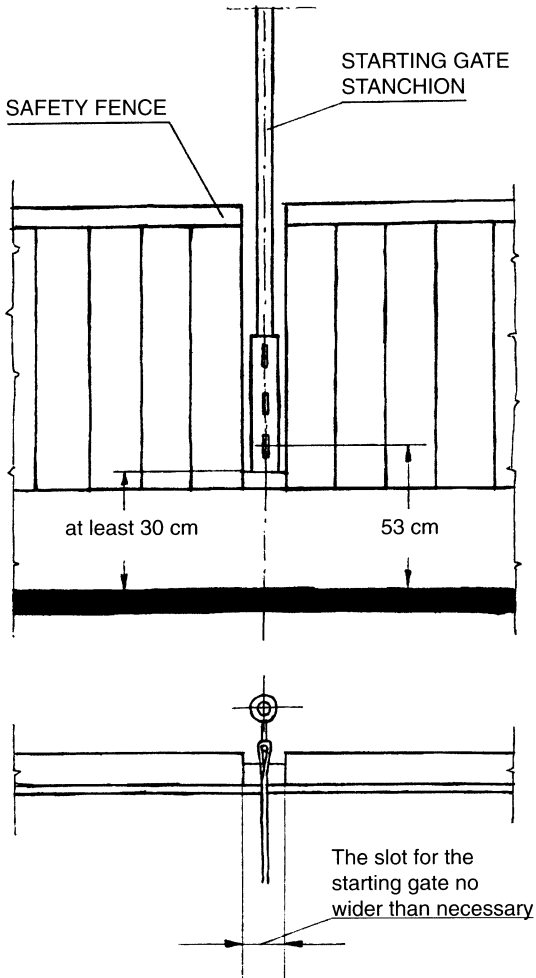

TEMPORARY FENCE OF STRAW BALES

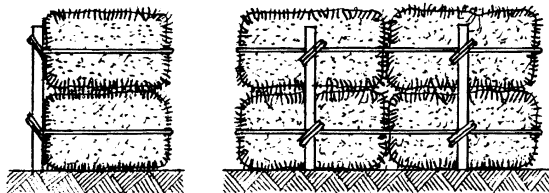
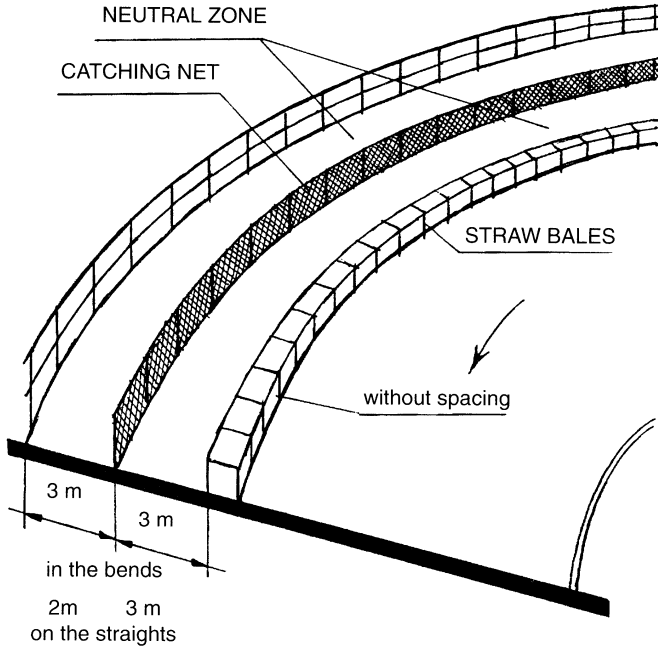

STRAW BALES MUST BE ATTACHED TO EACH OTHER

Illustrations / Drawings

FENCE WITH STRAW BALES ON TEMPORARY TRACKS

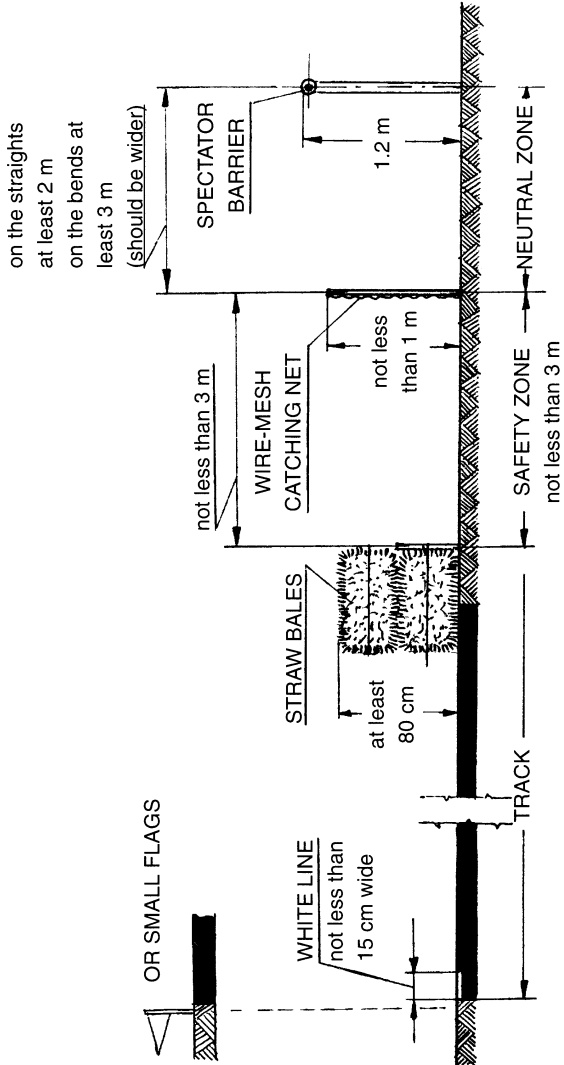

MARKING OF INSIDE EDGE (SPEEDWAY)

WHITE LINE

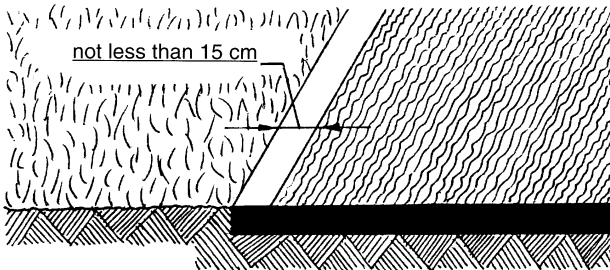

CONCRETE KERB

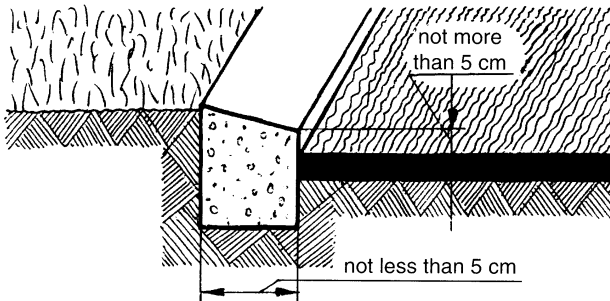

LIST OF WOOD OR SIMILAR MATERIAL

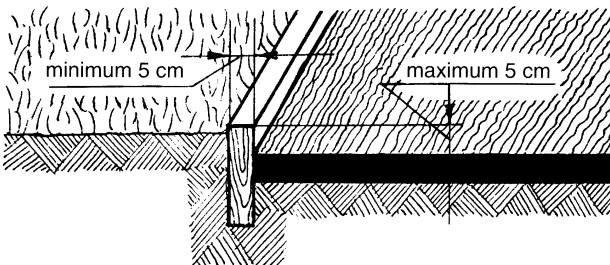

THE STARTING AREA

The starting line should be positioned in the middle of the straight, but never less than 35 m from the entrance to the first bend on Speedway and lde tracks; or not less than on 2/5 of the length of the straight before the first bend and not less than 3/5 of the length of the straight after the bend on Long and Grass tracks.

SPEEDWAY

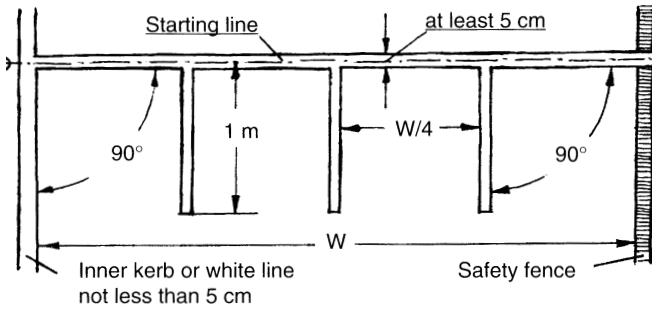

ICE RACING

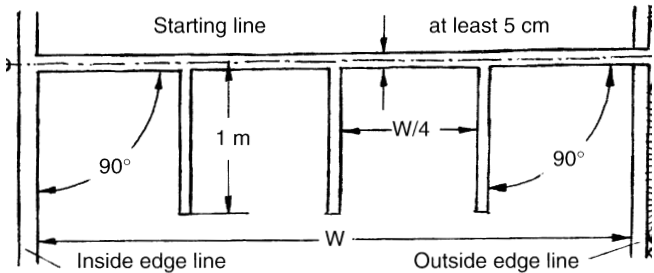

SPEEDWAY, LONG TRACK AND GRASS TRACK RACING

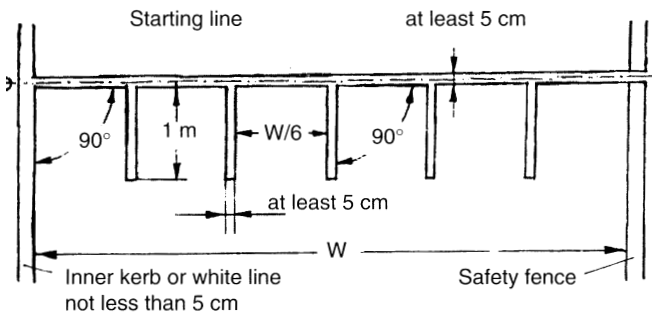

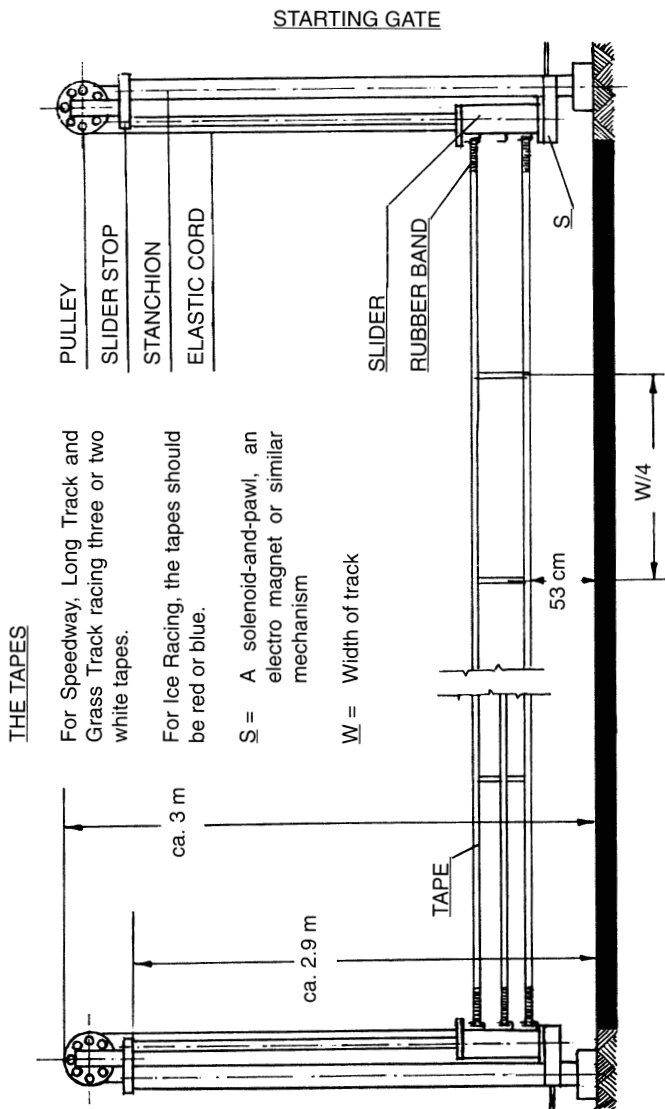

SIGNAL FLAGS AND DISCS

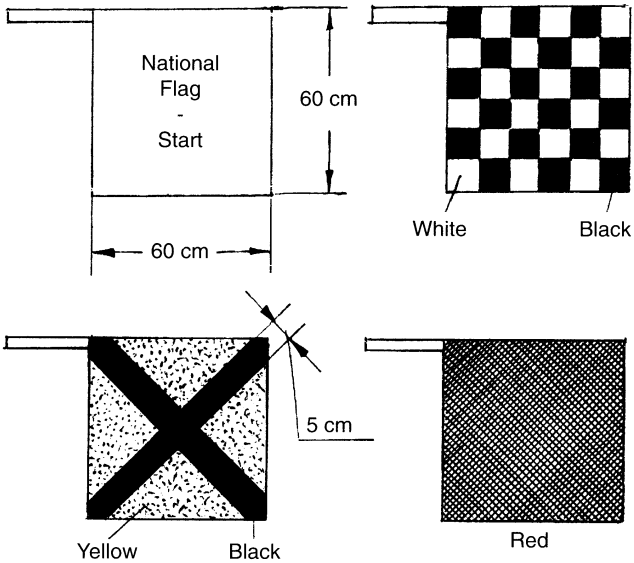

DISQUALIFICATION SIGNALS

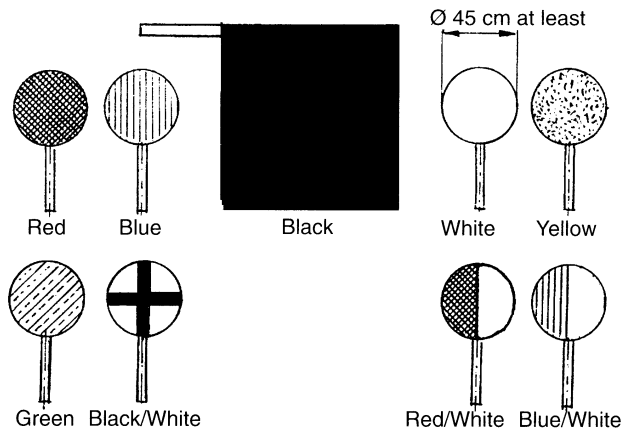

TRACK SIGNALS  
(SPEEDWAY, ICE AND LONG TRACKS)

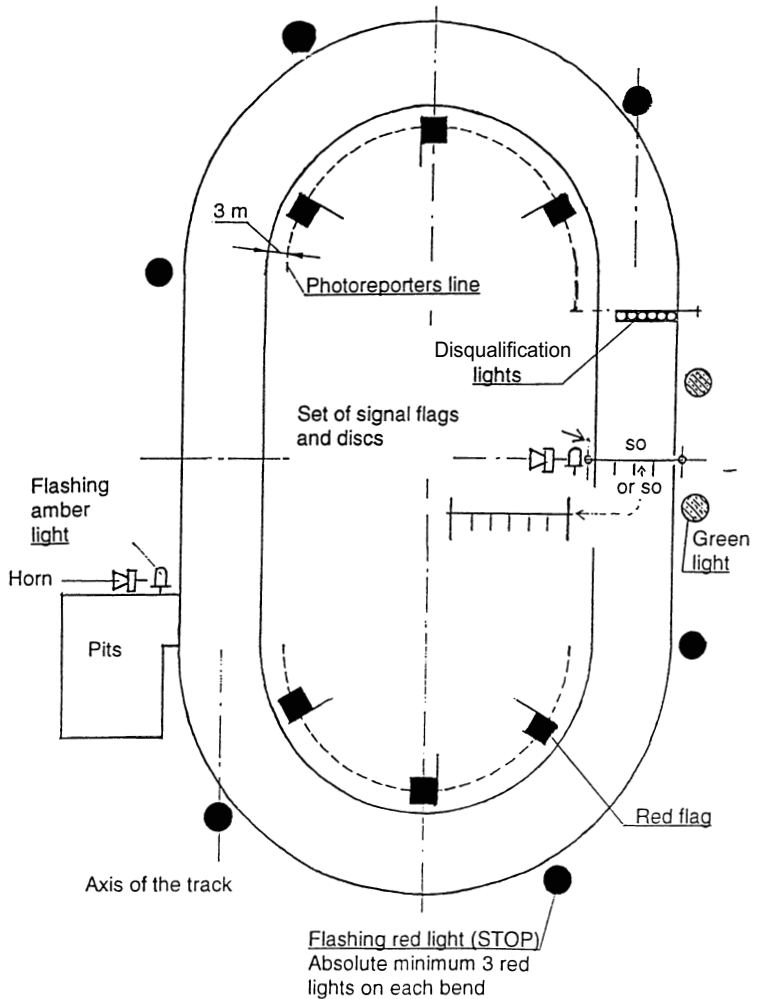

Illustrations / Drawings

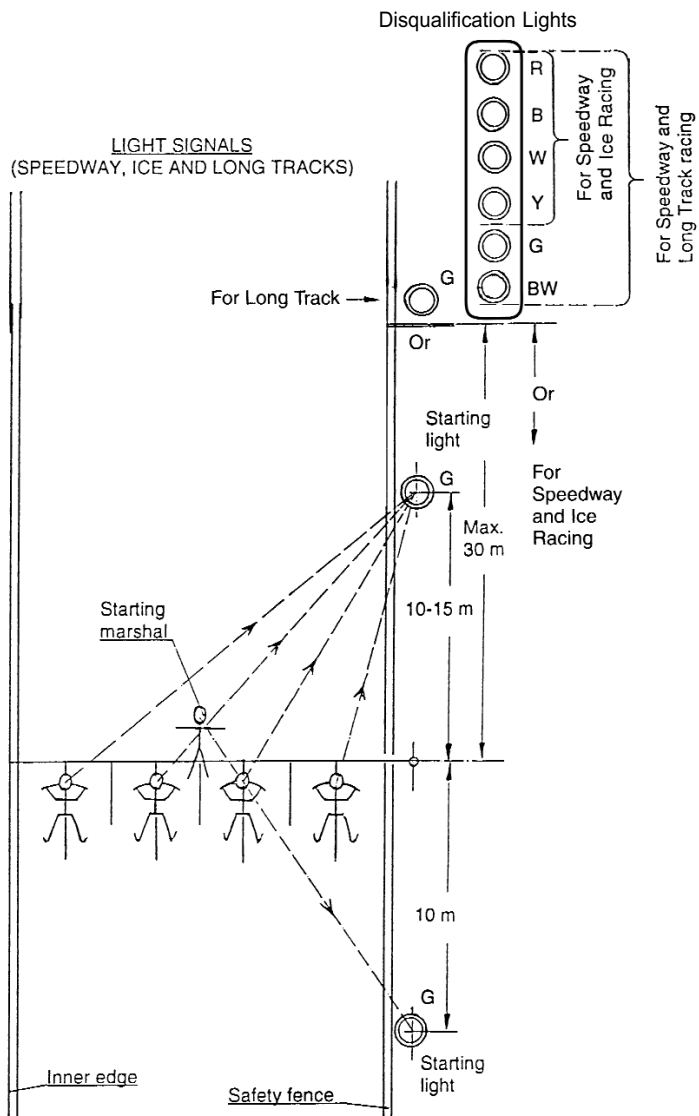

PIVOTS FOR RED STOP LIGHTS

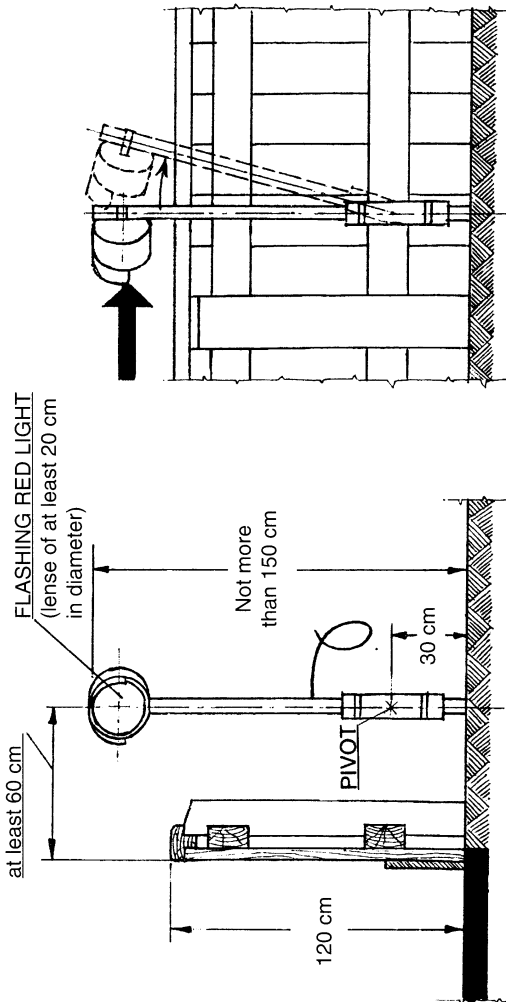

## ALIGNMENT WITH STARTING LINE

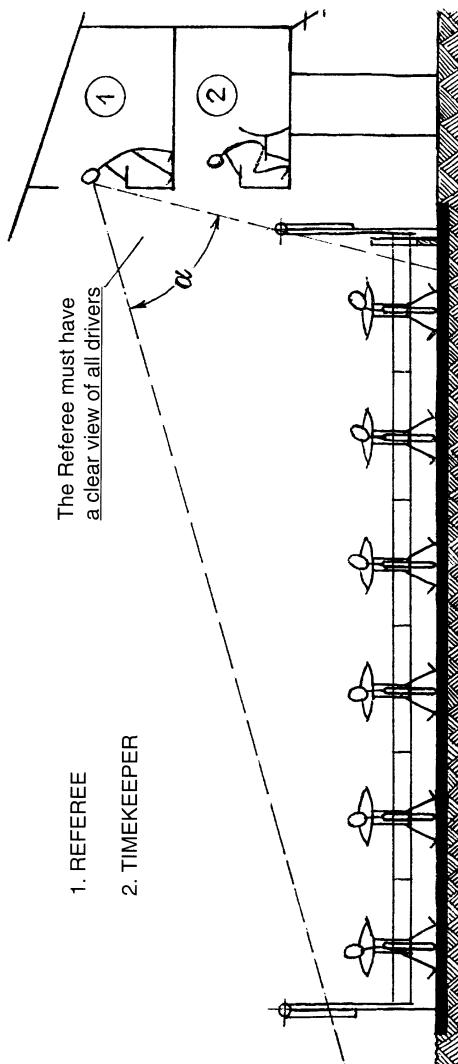

**PREFERABLE:** The accommodation for the Referee and the Timekeeper should be located on the starting side of the track, so that the Referee and the Timekeeper can align themselves with the starting line.

REFEREE'S CONTROL PANEL

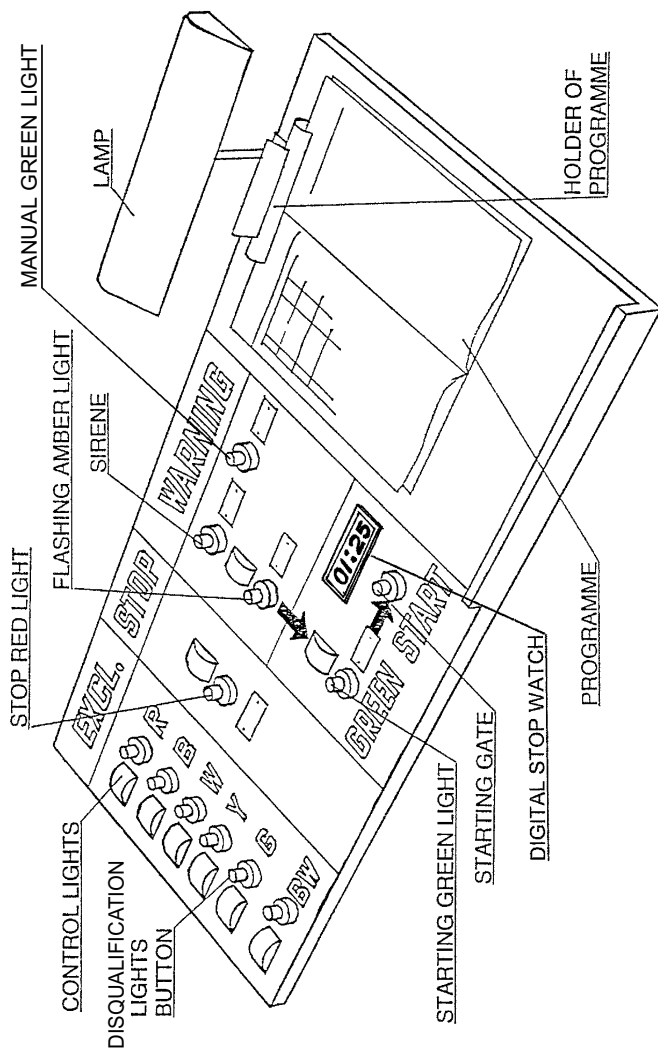

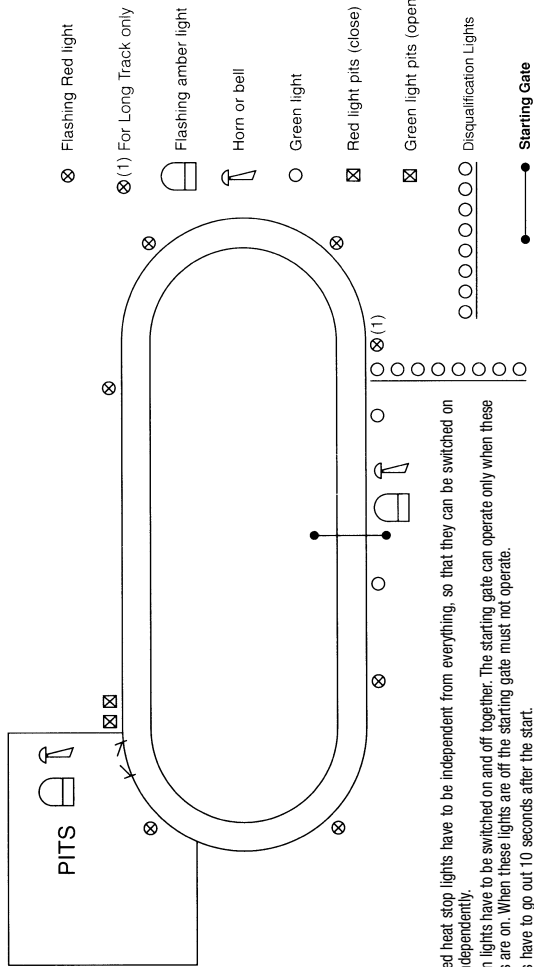

The six red heat stop lights have to be independent from everything, so that they can be switched on and off independently.

Two green lights have to be switched on and off together. The starting gate can operate only when these two lights are on. When these lights are off the starting gate must not operate.

The lights have to go out 10 seconds after the start.

Two flashing amber lights have to work together, one in the pits and one in the neighbourhood of the starting gate. They have to go out when the green starting lights have been switched on.

Two horns or bells have to go on and off together, one in the pits and one in the neighbourhood of the starting gate.

- Disqualification lights have to go on and off independently from each other.
- The green and red lights in the pits have to go on and off independently from each other.
- Start. The heat can only be started when the green starting lights are on.
- The stop watch should operate in conjunction with some of the switchboard buttons as follows:
  - Pressing the flashing amber light button: watch reset and start
  - Pressing the green light button: watch reset and start
  - Pressing the starting gate button: watch reset and start

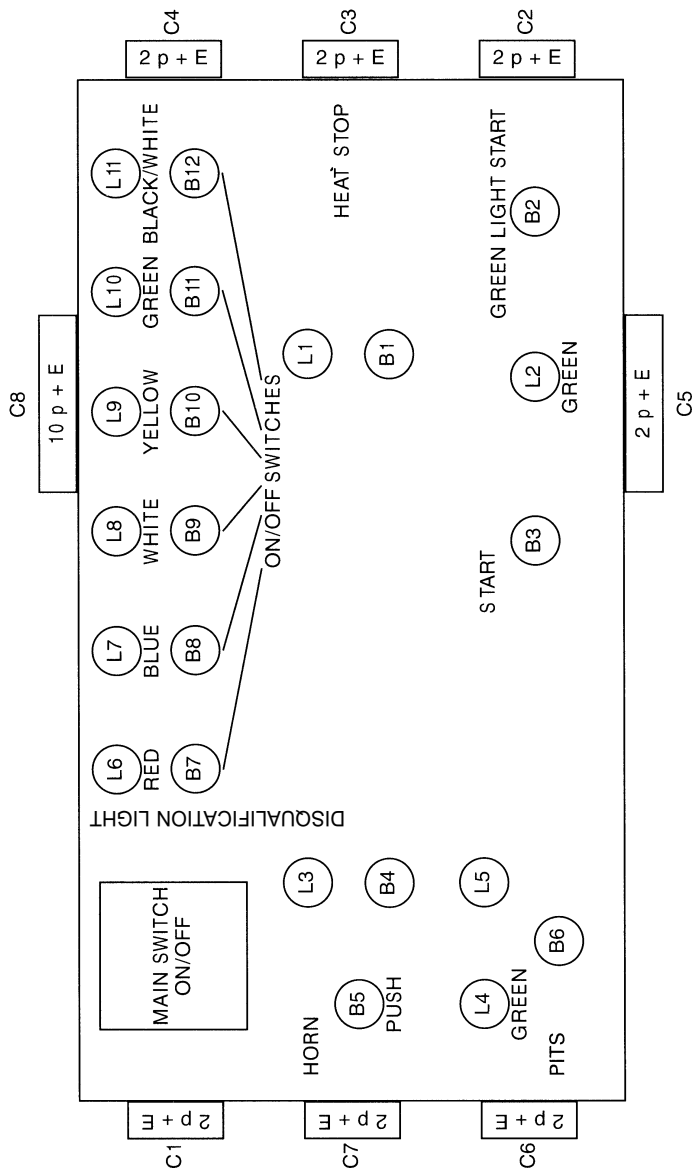

C1, C2, C3, C4, C5, C6, C7=2 p + E CONNECTOR

C8=10 p + E CONNECTOR

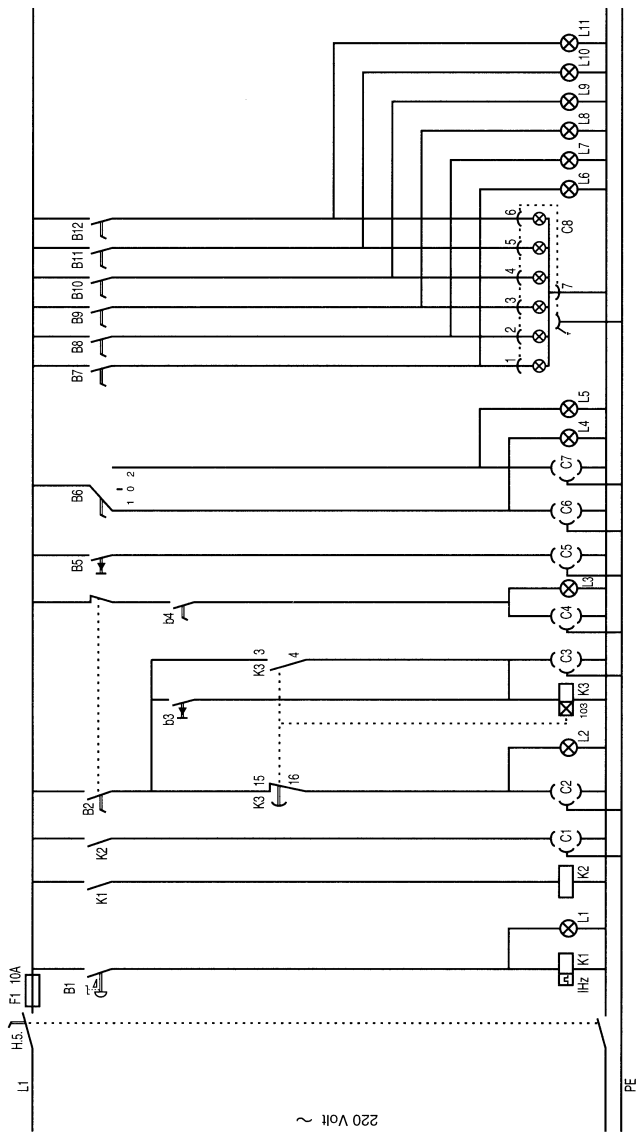

K1. Intermittent relay 0.55 sec. on 0.55 off  
 K2. Relay 220 Volt 6 Amp.  
 K3. Timing relay 1 directly and 1 deceleration relay 10 sec.  
 C1. 2 pen female connector 6 lights heat stop red  
 C2. 2 pen female connector 2 green lights start ready  
 C3. 2 pen female connector starting machine  
 C4. 2 pen female connector flashing amber lights  
 C5. 2 Pen female connector horn or bell

C6. 2 pen female connector green lights pits  
 C7. 2 pen female connector red light pits  
 C8. 10 pen female connector disqualification lights (6)  
 B1. Safety push button  
 B2. B4-B7-B8-B9-B11-B12. Switch on/off  
 B3-B5 Push button  
 B6. Switch on-neutral-off  
 F1. Fuse 10 Amp. 220 Volt

L1-L5-L6. Red control lights  
 L9. Yellow control light  
 L2-L4-L10. Green control lights  
 L11. Black/White control light  
 L3. Amber control light  
 L7. Blue control light  
 L8. White control light

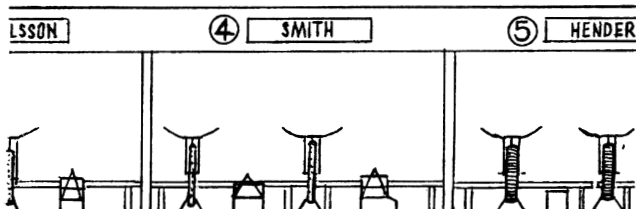
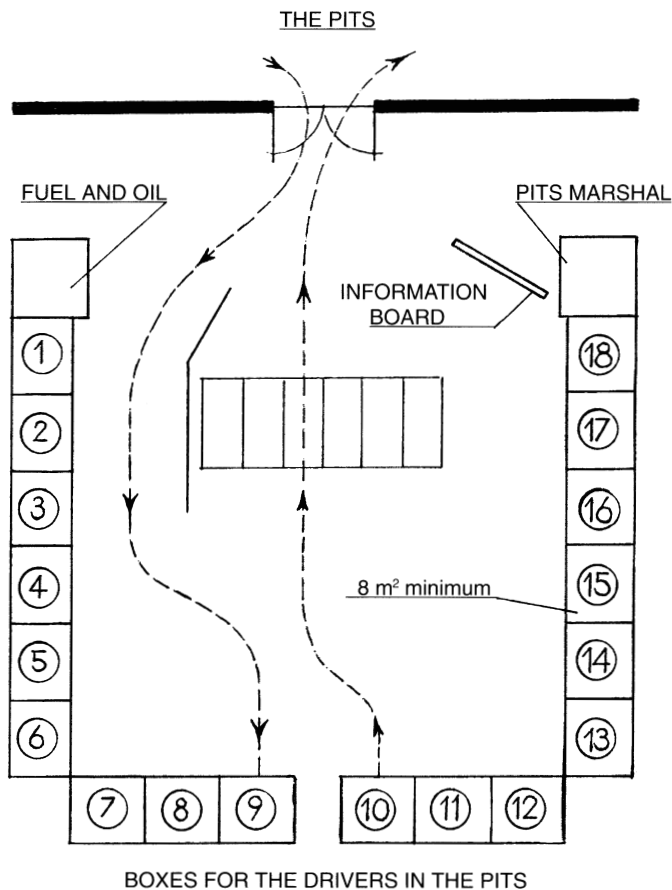

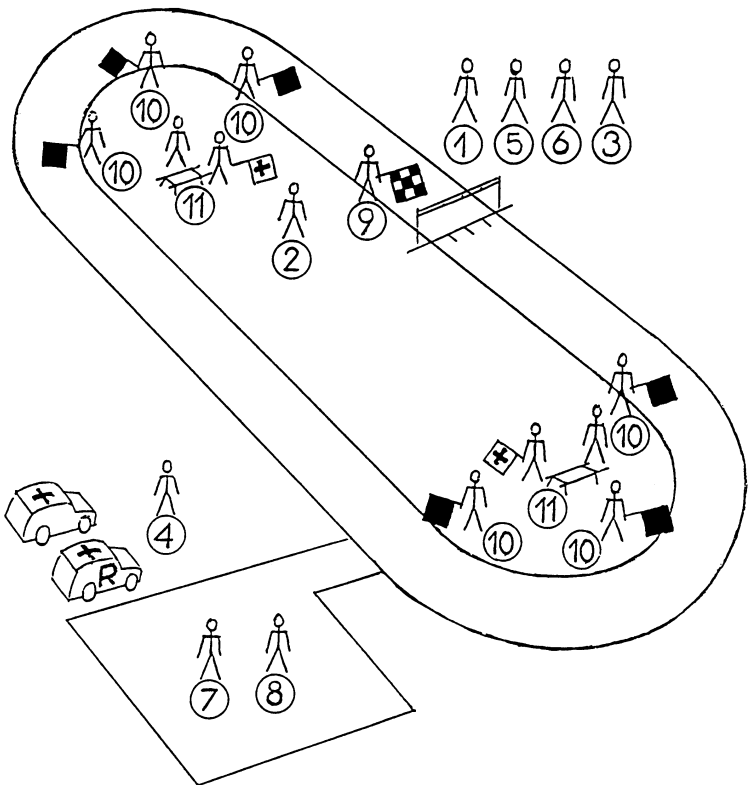
RACING OFFICIALS

- |                             |  |
|-----------------------------|--|
| 1. REFEREE                  | 7. TECHNICAL STEWARD   |
| 2. CLERK OF THE COURSE      | 8. PITS' MARSHAL   |
| 3. SECRETARY OF THE MEETING | 9. STARTING MARSHALL   |
| 4. DOCTOR                   | 10. FLAG MARSHALS<br>(three on each bend)                                |
| 5. TIMEKEEPER               | 11. FIRST-AID MEDICAL STAFF<br>(with a stretcher and a "Red-Cross" flag) |
| 6. SPEAKER                  |  |

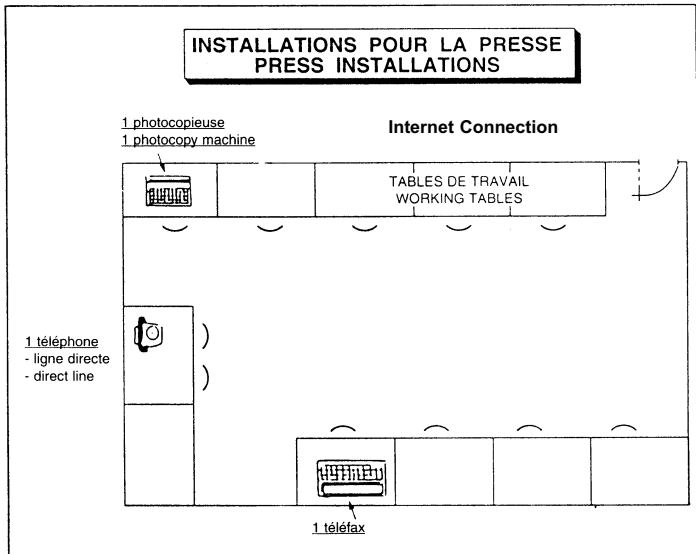

Annexe A / Appendix A

COORDONNEES DES CONSTRUCTEURS & DISTRIBUTEURS DES  
SYSTEMES DE PROTECTION ACCESSOIRES POUR COURSES SUR PISTES  
CO-ORDINATE OF MANUFACTURERS & DISTRIBUTORS OF TRACK  
RACING ADDITIONAL PROTECTIVE DEVICES

**Tony Briggs “No Pain Barrier”, “Catching Air”, “Air Net”**

Tony Briggs  
Lyndhurst, the Village  
Finchampstead, Berkshire RG40 4JR, UK  
Tel: + 44 1189 734 423 Mobile: +44 7768 438 233  
t.briggs@nopainbarriers.com

**ADMAR Speedway Air Barrier**

F.P.H.U. ADMAR  
Ul. Szttygarska 27  
PL 41-608 Swietochlowice  
Tel: +48 32 770 13 90 Fax: +48 32 770 88 22  
admar@admar.biz www.admar.biz

**VIV1 “Safety4all Plus”**

VIV1 SP. Z 0.0  
Ul. Glowna 5A  
PL 42-270 Garnek  
Tel: +48 343 281 695 Fax: +48 343 281 696  
viv@viv1.com www.viv1.com

**FUN4SALE.PL “Safety4all”**

FUN4SALE.PL  
Ul Brzeznicza 43 Lok. 16  
PL 97-500 Radomsko  
Tel: +48 697 990 137  
fun4sale.pl@gmail.com www.fun4sale.pl

**TENT GRUPA “Banda Pneumatyczna Ochronna”, “Safe Speedway  
Barrier”**

TENT GRUPA  
Ignatki 46  
PL 16-001 Kleosin  
Tel/Fax: +48 085 746 16 46  
biuro@tengrupa.pl www.tengrupa.pl

**Airfence “Airfence Speedway”, “Airfence Speedway Inflatable”**

Airfence Safety Systems (Australia)  
P.O. Box 7161, Geelong West  
Victoria 3218  
Australia  
Tel: +61 3 5229 1311 Fax: +61 3 5229 2544  
airfence@airfence.com www.airfence.com

**SIDIJK BV “Sidijk Impact Protection System”**

Postbus 65  
9000 AB Grou, The Netherlands  
info@sidijk.com www.sidijk.com  
Tel: +31 (0)566-625700 Fax: +31 (0)566-622769

**PROTAN LESJÖFORS AB “ProFence”**

Box 1062  
S-680 96 Lesjöfors, Sweden  
Lars-olov.larsson@protan.se www.protanlesjofors.se  
Tel: +46 (0)590-310-50 Fax: +46 (0)590-304-20