

FEDERATION INTERNATIONALE  
DE MOTOCYCLISME

**FIM ROAD RACING WORLD CHAMPIONSHIP  
GRAND PRIX REGULATIONS**

**REGLEMENTS DU CHAMPIONNAT DU  
MONDE FIM DES GRANDS PRIX DE  
COURSES SUR ROUTE**



**2010**

1st edition / 1ère édition

**Articles amended from 1.1.2010 are in bold red type**  
**Les articles modifiés depuis le 1.1.2010 sont en caractères gras rouges**

**FIM ROAD RACING WORLD CHAMPIONSHIP GRAND PRIX REGULATIONS**  
**REGLEMENTS DU CHAMPIONNAT DU MONDE FIM DES GRANDS PRIX DE**  
**COURSES SUR ROUTE**

This book (hereinafter collectively referred to as the "FIM Road Racing World Championship Grand Prix Regulations") has been printed on **31.01.2010**. Successive editions can be printed for supplementing and/or amending. The new editions will be numbered (2nd edition, 3rd edition, etc.), dated and issued to all relevant Bodies. / Ce livre (ci-après désigné collectivement sous la dénomination "Règlements du Championnat du Monde FIM des Grands Prix de Courses sur Route FIM") a été imprimé le **31.01.2010**. Des éditions successives peuvent être imprimées pour complément et/ou amendement. Les nouvelles éditions seront numérotées (2ème édition, 3ème édition, etc.), datées et transmises aux organismes appropriés.

**THIS BOOK PREVAILS OVER ALL OTHER FIM RULE BOOKS EXCEPT THOSE REFERRED TO AS AN APPENDIX. / CETTE BROCHURE PREVAIL SUR TOUS LES AUTRES REGLEMENTS FIM, A L'EXCEPTION DE CEUX QUI SONT RENVOYES A UNE ANNEXE.**

**Articles amended as from 1.1.2010 are in bold type**  
**Les articles modifiés dès le 1.1.2010 sont en caractères gras**

**Articles amended from 1.1.2010 are in bold red type**  
**Les articles modifiés depuis le 1.1.2010 sont en caractères gras rouges**

**2010**

1st edition / 1ère édition



FEDERATION INTERNATIONALE DE MOTOCYCLISME (FIM)

11, route Suisse  
CH - 1295 MIES  
Tel: +41-22-950 950 0  
Fax: +41-22-950 950 1  
www.fim-live.com  
[paul.duparc@fim.ch](mailto:paul.duparc@fim.ch)

DORNA SPORTS S.L. (DORNA)

C/ Pinar, 7  
E - 28006 MADRID  
Tel: +34 91 782.02.20  
Fax: +34 91 561.58.61 & +34.91.561.32.86  
[events@dorna.es](mailto:events@dorna.es)

INTERNATIONAL ROAD RACING TEAMS ASSOCIATION (IRTA)

c/o Road Racing Consultants Ltd.  
6, Valley Court offices  
Lower Road  
CROYDON – ROYSTON  
GB – HERTS SG8 OHF  
Tel: +44-1223-208 155  
Fax: +44-1223-207 276  
[IRTAUK@aol.com](mailto:IRTAUK@aol.com)

MOTORCYCLE SPORTS MANUFACTURERS' ASSOCIATION (MSMA)

Akasaka 4-5-21-317, Minato-Ku,  
Tokyo 107-0052  
JAPAN.  
Tel: +81-3-3568-2056  
Fax: +81-3-3568-2057  
[mail@msma-moto.com](mailto:mail@msma-moto.com)

## CONTENTS / SOMMAIRE

|    |   |
|----|---|
|    | GENERAL UNDERTAKINGS AND CONDITIONS<br>OBLIGATIONS ET CONDITIONS GENERALES..... |
| 1. | SPORTING REGULATIONS<br>REGLEMENTS SPORTIFS.....                                |
| 2. | TECHNICAL REGULATIONS<br>REGLEMENTS TECHNIQUES .....                            |
| 3. | DISCIPLINARY AND ARBITRATION CODE<br>CODE DISCIPLINAIRE ET D'ARBITRAGE .....    |
| 4. | CIRCUIT STANDARDS<br>NORMES POUR LES CIRCUITS .....                             |
| 5. | MEDICAL CODE<br>CODE MEDICAL .....  |
| 6. | ANTI-DOPING CODE<br>CODE ANTIDOPAGE   |
| 7. | ENVIRONMENTAL CODE<br>CODE DE L'ENVIRONNEMENT .....                             |

**2010**

1st edition / 1ère édition

## **GENERAL UNDERTAKINGS AND CONDITIONS**

### **1. SPORTING REGULATIONS**

|      |   |
|------|---|
| 1.1  | INTRODUCTION.....   |
| 1.2  | EVENTS.....   |
| 1.3  | THE PADDOCK.....  |
| 1.4  | OFFICIALS.....  |
| 1.5  | EVENT MANAGEMENT.....                                     |
| 1.6  | RACE DIRECTION.....                                       |
| 1.7  | THE FIM STEWARDS.....                                     |
| 1.8  | THE CALENDAR.....   |
| 1.9  | CLASSES.....  |
| 1.10 | ELIGIBLE COMPETITORS.....                                 |
| 1.11 | ENTRIES.....  |
| 1.12 | STARTING NUMBERS.....                                     |
| 1.13 | SCHEDULE.....   |
| 1.14 | TECHNICAL CONTROL – MEDICAL CONTROL – DOPING CONTROL..... |
| 1.15 | PRACTICE.....   |
| 1.16 | GRID POSITIONS.....                                       |
| 1.17 | RACES.....  |
| 1.18 | START PROCEDURE.....                                      |
| 1.19 | RIDE THROUGH PROCEDURE.....                               |
| 1.20 | "WET" AND "DRY" RACES.....                                |
| 1.21 | BEHAVIOUR DURING PRACTICE AND RACE.....                   |
| 1.22 | FLAGS AND LIGHTS.....                                     |
| 1.23 | MEDICAL CARS.....   |
| 1.24 | FINISH OF A RACE AND RACE RESULTS.....                    |
| 1.25 | INTERRUPTION OF A RACE.....                               |
| 1.26 | RE-STARTING A RACE THAT HAS BEEN INTERRUPTED.....         |
| 1.27 | CHECK AREA.....   |
| 1.28 | CHAMPIONSHIP POINTS AND CLASSIFICATION                    |
| 1.29 | INSTRUCTIONS AND COMMUNICATIONS TO COMPETITORS....        |
| 1.30 | TEAMS PERSONNEL IN THE PIT LANE.....                      |

### **2. TECHNICAL REGULATIONS**

|     |                   |
|-----|-------------------|
| 2.1 | INTRODUCTION..... |
| 2.2 | CLASSES.....      |
| 2.3 | ENGINES.....      |
| 2.4 | TRANSMISSION..... |
| 2.5 | WEIGHTS.....      |
| 2.6 | FUEL TANKS.....   |

|      |  |
|------|--|
| 2.7  | SAFETY AND CONSTRUCTION CRITERIA ..... |
| 2.8  | WHEEL RIMS .....                       |
| 2.9  | TYRE RESTRICTIONS .....                |
| 2.10 | NUMBERS AND BACKGROUNDS.....           |
| 2.11 | FUEL AND OIL.....                      |
| 2.12 | PROTECTIVE CLOTHING AND HELMETS .....  |
| 2.13 | PROCEDURES FOR TECHNICAL CONTROL.....  |
| 2.14 | NOISE TESTS .....                      |

**3. DISCIPLINARY AND ARBITRATION CODE**

|     |   |
|-----|---|
| 3.1 | PRINCIPLES .....  |
| 3.2 | PENALTIES .....   |
| 3.3 | THE DISCIPLINARY AND ARBITRATION BODIES .....                         |
| 3.4 | PROTESTS AND APPEALS .....  |
| 3.5 | PROCEDURE BEFORE ALL THE DISCIPLINARY AND<br>ARBITRATION BODIES ..... |
| 3.6 | COSTS OF PROCEDURE .....  |
| 3.7 | RECIPROCITY OF PENALTIES .....  |
| 3.8 | LAW OF MERCY .....  |
| 3.9 | ARBITRATION CLAUSE.....   |

**4. CIRCUIT STANDARDS .....**

**5. MEDICAL CODE**

|     |                                    |
|-----|------------------------------------|
| 5.1 | INTRODUCTION.....                  |
| 5.2 | SPECIAL MEDICAL EXAMINATION .....  |
| 5.3 | MEDICAL SERVICES AT EVENTS .....   |
| 5.4 | MEDICAL MALPRACTICE INSURANCE..... |

**6. ANTI-DOPING CODE .....**

**7. ENVIRONMENTAL CODE**

|                |
|----------------|
| DIAGRAMS ..... |
|----------------|

## **AMENDMENTS TO THE ROAD RACING FIM WORLD CHAMPIONSHIP GRAND PRIX REGULATIONS**

The FIM, through the Grand Prix Commission and the Grand Prix Permanent Bureau, may at any time amend any or all provisions of the Regulations.

**Any subsequent changes that take place after the printed versions are completed will be made electronically, and the on-line versions will be the prevailing versions.**

The Permanent Bureau consists of:

- One Representative of the Fédération Internationale de Motocyclisme (FIM).
- One Representative of DORNA.

which shall meet on a regular basis to discuss and decide on all issues of the FIM Grand Prix pertinent to the respective interests of the members.

The procedures for the calling of meetings of the Permanent Bureau and for procedures during such meetings (which may be held by telephone or other electronic means) and for the appointment and/or vacancy of representatives and all procedures for their deliberations shall be as mutually agreed by the members from time to time provided always that a decision of the Permanent Bureau shall only be effective with and upon the unanimous vote of the members.

The Grand Prix Commission is competent to study any proposal of changes to the FIM Road Racing World Championship Grand Prix Regulations.

The Grand Prix Commission consists of:

- One Representative appointed by the Fédération Internationale de Motocyclisme (FIM).
- One Representative appointed by the manufacturers, through MSMA.
- One Representative appointed by the teams and riders, through IRTA.
- One Representative appointed by DORNA who will be the Chairman of the Grand Prix Commission.

Any resolution voted by the Grand Prix Commission shall require the simple majority and the Chairman will have the casting vote in case of a tie. The resolutions of the Grand Prix Commission shall be effective subject to the approval of the Permanent Bureau. The parties shall procure that the meetings of the Grand Prix Commission take place no later than fourteen (14) days following the request of any Representative for that meeting.

## **General Undertakings and Conditions**

**These Regulations derogate and supersede all and any other previous regulations in place before the date of publication of these regulations.**

All riders, team personnel, officials, promoters/organizers and all the persons involved in any capacity whatsoever participating in the Road Racing FIM World Championship Grand Prix (hereinafter collectively referred to as the "Championship") undertake, on behalf of themselves, their employees, and agents, to observe all the provisions of:

1. SPORTING REGULATIONS
2. TECHNICAL REGULATIONS
3. DISCIPLINARY AND ARBITRATION CODE
4. CIRCUIT STANDARDS
5. MEDICAL CODE
6. ANTIDOPING CODE
7. ENVIRONMENTAL CODE

as supplemented and amended from time to time (hereinafter collectively referred to as the "Regulations").

All the persons mentioned above may be penalised in accordance with the provisions of the Regulations.

Whilst the Regulations may be translated into other languages, in case of any dispute regarding interpretation the Official English text will prevail.

It is the responsibility of the team to ensure that all persons concerned with its entry observe all the requirements of the Regulations. The responsibility of the rider, or any other person having charge of an entered machine during any part of the Event with respect to observance of the Regulations is joint and several with that of the team.

All persons concerned in any way with an entered machine or present in any capacity whatsoever in the Paddock, Pits, Pit lane or Track, must wear an appropriate pass at all times during the Event.

### **ANTIDOPING CODE**

All the persons concerned must at all times observe the FIM Anti-Doping Code and may be penalised accordingly.

## 1. SPORTING REGULATIONS

### 1.1 Introduction

- 1.1.1 A series of motorcycle races counting toward the FIM World Championship for Riders and Constructors (**engine for 125cc and MotoGP; frame for Moto2**) will be organised.

### 1.2 Events

- 1.2.1 The Event shall be deemed to commence at the scheduled time for Technical and Sporting Checks and finish after all the races at the expiry of the deadline for the lodging of a protest and the time at which technical or sporting verifications have been concluded, whichever is the latest.

The race control must remain operative with all equipment in place until the end of the period provided for the lodging of a protest, and all officials and marshals must remain at the circuit available to the Race Direction and FIM Stewards during that period.

- 1.2.2 Events must be staged on race circuits that have been approved by the FIM for the Championship.
- 1.2.3 Events must not include any other races except for support races approved by the FIM and DORNA.
- 1.2.4 Any activity involving 4 wheels racing vehicular use of the track during the event, including "demonstrations", displays or the suchlike must receive prior approval from FIM and Dorna.
- 1.2.5 Organisers will be nominated by the FIM and DORNA.
- 1.2.6 The Organiser is responsible for providing the facilities and personnel to ensure the smooth and efficient running of the event.
- 1.2.7 The organiser will arrange third party liability insurance including cover for all participants, teams, sponsors, service companies, officials, FIM, DORNA, IRTA, etc.

The cover provided for each event shall be US \$ 6 million, with the exception of the USA and Canada, where the cover shall be different.

The organiser will send a copy of such liability insurance to Dorna by courier or telefax, at least 30 days prior to its event. At least 15 days prior to the event; Dorna shall let the organiser know if some amendments must be made to the aforesaid liability insurance to meet the insurance laws of the organiser's country.

The validity of the insurance must start at 08:00 hrs, on the Wednesday (or Tuesday in the case of Saturday races) before the race and finish at 24:00 hrs on the Monday (or Sunday in the case of Saturday races) after the race.

1.2.8 At least 90 days prior to the Event, the Organisers of the event must submit the following information to the FIM and DORNA:

- a - Confirmation of the name and address of the Promoters/Organisers, including telephone and facsimile numbers for correspondence.
  - b - The date and place of the Event.
  - c - A detailed plan of the circuit, its direction, clockwise or anticlockwise, and length.
  - d - The location at the circuit of the rider information centre and the official notice board.
  - e - The name and address of the company providing the third party liability insurance cover and the number of the policy.
  - f - Name and address of FMNR.
  - g - The name of the Clerk of the Course (with FIM Clerk of the Course licence).
  - h - The name, address and telephone number of the Chief Medical Officer.
  - i - The name, address and telephone number of the hospitals designated for the event.
- N.B. The Organiser is not required to produce or publish any Supplementary Regulations for the event.

- 1.2.9 At least 60 days before the Event, DORNA must publish the above information and post it to IRTA for distribution to all teams with an entry for the Event.

### **1.3 The Paddock**

- 1.3.1 The Paddock, pit boxes and all other facilities must be available to teams at least on the Wednesday prior to a Sunday race and remain available to competitors for at least one day and, if possible, two days after the event.
- 1.3.2 Access must be available for teams arriving to set up between the hours of 08:00 and 22:00.
- 1.3.3 At all times that the Paddock is occupied there must be 24 hour attendance at the gates providing vehicular access to the circuit and paddock.
- 1.3.4 When the Paddock is occupied there must be an adequate medical and fire fighting service available to all riders, teams, manufacturers, sponsors, service companies, officials, FIM, Dorna, IRTA, etc. At minimum the services must be available from 08.00 – 18.00hrs on the two days prior to the “setting up of teams day”, and on a 24 hour basis for the remainder of the event, ending at midnight on the day after race day.
- 1.3.5 Full security must be supplied to the Paddock area from at least midnight of the Wednesday prior to a Sunday race until midnight of the Monday following the race.

### **1.4 Officials**

All the following Officials must be present and available at the time necessary to ensure smooth and efficient running of the Event:

#### **1.4.1 Permanent Officials**

All permanent officials shall be appointed for the Championship by the Permanent Bureau.

The following officials will be appointed to perform supervisory and executive roles. Except in cases of illness or Force Majeure the officials will be expected to be present at each event.

**Race Director** Responsible for ensuring proper observance of the Regulations and efficient running of the practice and races. The Race Director is also responsible for all communications between the Event Management Committee and the FIM Stewards.

The Race Director has no competence for the application of sanctions.

The Clerk of the Course shall work in permanent consultation with the Race Director. The Race Director shall have overriding authority in the following matters and the Clerk of the Course may give orders in respect of them only with his express agreement:

- a) The control of practice and the race, adherence to the timetable and, if he deems it necessary, the making of any proposal to the Race Director to modify the timetable in accordance with the Sporting Regulations.
- b) The stopping of practice or the race in accordance with the Sporting Regulations if he deems it unsafe to continue and ensuring that the correct restart procedure is carried out.
- c) The starting procedure.
- d) The use of medical cars/fast interventions vehicles.

**Technical Director** Responsible for ensuring that technical Regulations are correctly enforced and supervising scrutineering and protests of a technical nature.

**Medical Director** Responsible for liaison with the Chief Medical Officer appointed by the Organisers to ensure compliance with the Medical Code.

**FIM Safety Officer** Responsible for the supervision of all aspects of safety.

**Starter** Responsible for the start procedure.

#### 1.4.2 **Individual Event officials**

All individual Event Officials shall be appointed for each event by the FMNR/Organiser.

They are:

- i) **Clerk of the Course** Responsible for:

- a - Ensuring that the circuit is suitably prepared for and maintained during the Event and that all legal requirements applicable for the running of the event have been complied with.
- b - Ensuring that all officials and services are in place.

The stationing of all track personnel and equipment (i.e. marshals, doctors, ambulances, flags, etc.) alongside the Circuit no later than 30 minutes prior to the beginning of all practice sessions and warm-ups.

The Race Director, the FIM Safety Officer, the Clerk of the Course and the Medical Director will make the final inspection of the Circuit to ensure this regulation is complied with, 30 minutes prior to the beginning of the all practice sessions and warm up.

During the final inspection lap, the yellow flag must be waved at each flag marshal post together with the display of other flags and equipment requested by the FIM Safety Officer.

- c - Taking decisions to ensure the smooth and efficient running of the event.
- d - Ensuring that the event is run within the Regulations.
- e - Notification of protests to the Race Direction.
- f - Immediate approval and signature with time of provisional results (practices, warm-ups, starting grids and races) and presentation of reports to the Event Management Committee.

ii) **Secretaries** Responsible for:

- a - During the event effecting communications between the various officials.
- b - Providing secretarial support for the Event Management Committee, the Race Direction and the FIM Stewards.

iii) **Other Officials** Marshals, Technical Scrutineers, Security Personnel, Medical personnel etc., as required for the efficient running of the event.

All communications between the individual Event Officials must be made via the relevant Permanent Officials.

#### 1.4.3 **The Race Direction**

The Race Direction shall be appointed for the Championship by the Permanent Bureau.

#### 1.4.4 **The FIM Stewards**

The FIM Stewards shall be appointed for each event by the FIM.

### 1.5 **Event Management**

1.5.1 The management of the event will be carried out by the Event Management Committee which will comprise the following delegates:

The Race Director - who will chair the meetings  
The Technical Director  
The Medical Director  
The Clerk of the Course  
The Delegate appointed by DORNA  
The FIM Safety Officer

1.5.2 At any time the duties of the members of the Event Management Committee are :

- a - To ensure the smooth and efficient running of the event.
- b - To make recommendations to the Race Direction concerning any matter that is in contradiction to the Regulations.
- c - To report to the Race Direction any infringements of the Regulations.

1.5.3 The Event Management Committee will meet at any time required during the event, but at least:

- a - Prior to the first practice session.
- b - At the end of each practice day.
- c - At the end of the event.

- 1.5.4 The quorum for a meeting of the Event Management Committee is three persons.
- 1.5.5 All of the members have one vote. Decisions are based on a simple majority. In the case of a tie, then the Race Director will exercise a casting vote.
- 1.5.6 The Chief Steward may attend the meetings of the Event Management Committee and the Race Director may also invite the participation of Officials or other persons to assist in the meetings. However, the Chief Steward and the invited officials or other persons will have no right of vote.
- 1.5.7 The duties of the Event Management Committee are:
- a - To receive reports from the various Officials concerning scrutineering, practice and races.
  - b - To make recommendations to the organiser to improve the smooth and efficient running of the event.

## **1.6 Race Direction**

- 1.6.1 The Race Direction will comprise the following persons :
- The FIM Representative
  - The DORNA Representative
  - The IRTA Representative
  - The IRTA Riders' Representative
- 1.6.2 The quorum for a meeting of the Race Direction is three persons.
- 1.6.3 Each member has one vote. Decisions are based on a simple majority.
- 1.6.4 The Race Direction will meet at any time required during the event.
- 1.6.5 The duties of the Race Direction are:
- a - To take decision as provided in the Regulations.
  - b - To impose penalties for any infringements of the Regulations.

- c - To impose penalties on organisers for having been unable to ensure the smooth and efficient running of the event or for serious breaches of the Regulations.
- d - To adjudicate on any protest relating to infringements of the Regulations.

## **1.7 The FIM Stewards**

- 1.7.1 There will be a panel of three FIM Stewards (with FIM Sporting Steward licence) supervised by the Chief Steward who will chair the meetings.
- 1.7.2 The Chief Steward and the other Stewards are responsible for enforcing the Regulations. All Stewards officiating at more than four Grand Prix in any year shall be approved by the Permanent Bureau.
- 1.7.3 The quorum for a meeting of the FIM Stewards is two persons.
- 1.7.4 If the Chief Steward is indisposed during the Event then the second FIM Steward will fill the vacancy.
- 1.7.5 Each member has one vote. Decisions are based on a simple majority. In the case of a tie, the Chairman will exercise a casting vote.
- 1.7.6 The FIM Stewards have no executive role in the running of the events.
- 1.7.7 The FIM Stewards will meet at any time required during the event.
- 1.7.8 The FIM Stewards are responsible for:
  - a - Ensuring that the event is conducted according to the Regulations and reporting any infringement to the Race Direction.
  - b - Adjudicating on any appeal against the decisions of the Race Direction.
- 1.7.9 All decisions of the FIM Stewards must be communicated in writing to the Race Direction and all affected parties.

## **1.8 The Calendar**

1.8.1 The calendar of races counting for the Championships will be, in principle, published by no later than 31st October of the preceding year.

## 1.9 Classes

1.9.1 Classes will be for the following categories:

|              |                                |
|--------------|--------------------------------|
| 125          | 125cc single cylinder          |
| <b>Moto2</b> | <b>Moto2 – official engine</b> |
| MotoGP       | 800cc 4 stroke                 |

1.9.2 Technical Regulations governing the three classes are provided in the FIM Grand Prix Technical Rules for the FIM Championship.

## 1.10 Eligible Competitors

1.10.1 In order to compete in the Championship, riders must be officially entered by a member team of IRTA (with the exception of wild card riders, see Art. 1.11.5/6/7).

The rider must be in possession of an "FIM Grand Prix Licence" or an "FIM Superlicence" issued by a FMN. Riders are designated by IRTA/Grand Prix Commission. Licences can, in certain circumstances, be for a single event. To receive a Licence, the rider must be in possession of a national licence of a FMN at no additional cost to the rider.

Licences for riders are issued only when the minimum age has been attained as below:

- 125 cc: **16 years**
- **Moto2** **16 years**
- MotoGP: 18 years

The limit for the minimum age starts on the date of the rider's birthday.

For the Moto2 contracted riders and MotoGP class, the limit for the maximum age finishes at the end of the year in which the rider reaches the age of 50.

For the Moto2 class, the age limit for wild card riders is 28 years at the 1<sup>st</sup> of January of the corresponding Championship year.

For the 125cc class, the maximum age is 28 years (25 years for new contracted riders participating in the 125cc Grand Prix for the first time and for wild cards) at the 1<sup>st</sup> of January of the corresponding Championship year.

The constructors must be in possession of the appropriate "FIM Manufacturer Licence".

## **1.11 Entries**

- 1.11.1 Each team, being a member of IRTA, must submit to the Secretariat of IRTA, by 28 February of the year in question, an entry for their team which will, except when special dispensation is granted, be valid for all races in the Championship. At the same time, the team must indicate the riders designated and the class in which they will participate together with the Testing Circuits designated by the team in the 125cc and Moto2 classes.
- 1.11.2 Each entry must specify, for each rider, the insurance company providing the minimum cover specified by IRTA, the number of the policy and the expiry date of the policy.
- 1.11.3 Each entry commits the team to designate a rider to compete in all the events of the Championship in the chosen class. Exceptions can only be made as follows:
- i) A team may withdraw a rider from an event which has already started, due to injury of the rider, irreparable damage to the motorcycle(s) or in case of "Force Majeure". A withdrawal for medical reasons must be supported by a letter from the Chief Medical Officer of the meeting or the Medical Director.
  - ii) A team may withdraw a rider from additional events in the Championship only for medical reasons or other reasons of "Force Majeure". Withdrawals for medical reasons must be supported by a letter from a qualified Doctor and are subject to verification by another medical practitioner appointed by IRTA at its own expense. DORNA shall then have the right to require an additional examination and verification by at least two other medical practitioners appointed by DORNA for that purpose. In the event that the medical practitioners appointed by DORNA do not support the opinion of the medical practitioner appointed by IRTA, the following shall apply:

a) the opinion of the medical practitioners appointed by DORNA shall be deemed to prevail;

and

b) IRTA shall pay all costs incurred in the examination and reporting by the medical practitioners appointed by DORNA .

Teams must make every reasonable effort to provide a qualified substitute rider to fulfil their entry obligations. However no substitution or replacement of the entered rider may be made after **10H30 on the first day of practice** except in the MotoGP class when the limit is **2 hours before the qualifying practice**

iii) For reasons not being medical reasons and not being reasons of "Force Majeure", and subject to the Team obtaining the approval of IRTA and then subject to IRTA obtaining the approval of DORNA/FIM (neither of whom shall be obliged to give reasons for any refusal to approve), a Team may replace a rider which that Team has entered in the Championship with another rider ("replacement rider") for remaining rounds of the Championship. Only one replacement of a rider will be permitted per season. Exceptional circumstances will be examined by IRTA and DORNA/FIM.

1.11.4 If a team is unable to provide a substitute rider, then IRTA may decide to allow another team to enter a rider, on an event by event basis, to reach the required number of entries. Article 1.10.1 will apply to all replacement and substitute riders.

1.11.5 Each Grand Prix host Federation (FMNR) may nominate 3 wild card entries for the 125cc **class** and **one wild card entry for the Moto2 class** in their own Grand Prix only.

No wild card entry will be granted to a rider who has ridden in the event as a wild card on 3 previous occasions in the same class. **(For the purpose of this regulation the Moto2 class is considered as being the same as the 250cc class).**

Wild card riders must be holders of an FIM "one event Road Racing Grand Prix" licence issued by any FMN and entries must be submitted by the FMNR to the FIM, on the official entry form issued by the FIM, at least 30 days **for 125cc class and 45 days for Moto2 class** before the event.

These entries will be submitted to the approval of the Grand Prix Commission.

All financial arrangements for compensation or reward of wild card riders are the responsibility of the FMNR (Federation organising the event).

Wild card entries are not subject to the insurance requirements under 1.11.2. Insurance of the wild card riders is the responsibility of the FMNR (Federation organising the event).

- 1.11.6 The MSMA (Motorcycle Sport Manufacturers' Association) may, at each event, nominate 1 wild card entry for the **MotoGP class**. Wild card riders must be holders of an FIM "one event Road Racing Grand Prix" licence issued by any FMN and entries must be submitted by the MSMA to the FIM, on the official entry form issued by the FIM, at least 30 days before the event. The entries will be submitted to the approval of the Grand Prix Commission.

All financial arrangements for compensation or reward of wild card riders designated by the MSMA are the responsibility of MSMA.

Wild card riders designated by the MSMA are subject to the insurance requirements stipulated under 1.11.2.

- 1.11.7 The FIM may, at each event, nominate 2 wild card entries for the 125cc **class** and **one wild card entry for the Moto2 class** and FIM/DORNA may, at each event, nominate 1 wild card entry for the MotoGP class.

No 125cc and Moto2 wild card entry will be granted to a rider who has ridden in the event as a wild card rider on 3 previous occasions in the same class. **(For the purpose of this regulation the Moto2 class is considered as being the same as the 250cc class).**

Wild card riders must be holders of an FIM "one event Road Racing Grand Prix" licence issued by any FMN and entries must be submitted to the FIM, on the official entry form issued by the FIM, at least 30 days **for 125cc class and 45 days for Moto2 class** before the event. These entries will be submitted to the approval of the Grand Prix Commission.

There will be no financial arrangement for compensation or reward.

Wild card riders designated by the FIM and the FIM/DORNA are subject to the insurance requirements stipulated by their FMN.

1.11.8 A compulsory briefing will be held for all the riders who will be participating for the first time in the current Championship, at **10:30** hrs on the day-scheduled for the first practice session.

Failure to attend the briefing in full will result in disqualification from the event.

A waiver can be granted to a rider by the Race Direction.

1.11.9 A rider shall be deemed to have taken part in the event when he participates in, at least, one practice session.

1.11.10 A rider shall be deemed to have started a race when he participates in, at least, the first lap of the race.

**1.11.11 Riders who enter the Championship for the first time (Rookies) must be entered by a non factory team.**

## **1.12 Starting Numbers**

1.12.1 Each rider accepted for the Championship will be allocated a specific starting number which will be valid for the whole Championship. In general, the starting numbers will be based on the results of the team riders in the previous year's Championship or in other similar events.

## **1.13 Schedule**

1.13.1 The **provisional** event schedule will be as follows:

**WEDNESDAY** : Arrival and setting up of Teams

**THURSDAY** : Arrival and setting up of Teams  
10:00 - 17:00 Technical and Sporting Checks and other formalities

### **FRIDAY**

### **FREE PRACTICE**

**125cc:** 12.40-13.40

**MotoGP:** 13.55-14.55

**Moto2:** 15.10-16.10

### **SATURDAY**

### **FREE PRACTICE QUALIFYING PRACTICE**

|                |                    |                    |
|----------------|--------------------|--------------------|
| <b>125cc:</b>  | <b>09.00-09.40</b> | <b>13.00-13.40</b> |
| <b>MotoGP:</b> | <b>09.55-10.55</b> | <b>13.55-14.55</b> |
| <b>Moto2:</b>  | <b>11.10-12.10</b> | <b>15.10-15.55</b> |

### **SUNDAY**

### **WARM UP**

|                |                    |
|----------------|--------------------|
| <b>125cc:</b>  | <b>08.40-09.00</b> |
| <b>Moto2:</b>  | <b>09.10-09.30</b> |
| <b>MotoGP:</b> | <b>09.40-10.00</b> |

### **RACE**

|                |              |
|----------------|--------------|
| <b>125cc:</b>  | <b>11.00</b> |
| <b>Moto2:</b>  | <b>12.15</b> |
| <b>MotoGP:</b> | <b>14.00</b> |

1.13.2 The above schedule can only be varied as follows:

- i) Prior to the event by Dorna;
- ii) During the event by the Race Direction.

## **1.14 Technical Control – Medical Control – Doping Control**

1.14.1 Teams in the MotoGP class may present a maximum of two motorcycles per rider for Technical Control which will be carried out according to the published schedule, prior to the first practice. In the 125cc **and Moto2** classes, teams may present only one motorcycle per rider for Technical Control.

Unless a waiver is granted by the Race Direction, teams who do not comply with the schedule for technical or medical controls will not be allowed to take part in the event.

1.14.2 The procedure for Technical Control is described in the Technical Regulations, articles 2.12 and 2.13. The procedure for Medical Control is described in the Medical Code.

1.14.3 Any rider to be tested for doping control must report to the doping control room in the medical centre with sufficient identification within one hour of notification. One associate may accompany the rider.

## 1.15 Practice

### 1.15.1 Practice Restrictions

**For the purpose of practice restrictions the year is divided into two parts.**

The Season is defined as the period starting **14** days before the first race of the year and ending **3** days after the last race of the year, both dates being inclusive. The season does not include "Breaks". A Break is defined as two consecutive week-ends where events are not scheduled. The period of the Break extends from 09h00 on the second day after the Grand Prix until the following Grand Prix.

The Winter is defined as the rest of the year i.e. starting **4** days after the last race of the season and ending **15** days before the first race of the subsequent season both dates being inclusive.

#### 1.15.1.1 MotoGP Class

**A. Practice by contracted** riders with machines eligible for the MotoGP class is forbidden:

**i) During the Season and the breaks** at any circuit ~~included in the Grand prix calendar of the current year~~ with the following exceptions:

- a) Practice included in the schedule of the events.
- b) Practice during the day immediately following **the Spanish Grand Prix (Jerez) and the Czech GP (Brno) and during the 2days immediately following the last GP (Valencia).**
- c) Any activity authorised by the Race Direction.**

**ii) During the Winter** at any circuit with the following exceptions:

a) At a maximum of **6 days of** official tests organised by Dorna/IRTA at Grand Prix circuits included in the calendars of the preceding or following year. **No testing is permitted during the period starting on the 1<sup>st</sup> December of one year and finishing on 31<sup>st</sup> January of the following year, both dates being inclusive with the exception of the the "Rookie" riders who are allowed one 3 day test during November/December .**

**The Winter test schedule must be approved by the Grand Prix Commission.**

b) Any activity authorised by the Race Direction.

## **B. Practice by non-contracted riders:**

**Practice by non-contracted riders (test riders) is allowed at any circuit at any time, but limited by the use of a total of 240 tyres per manufacturer, per calendar year, supplied exclusively by the MotoGP tyre supplier. However, it is forbidden to test:**

During the Season and the Breaks at a Grand Prix circuit included in the calendar before the race has taken place. However manufacturers may, before 31<sup>st</sup> January of each year, designate and inform the Race Direction of their 2 testing circuits at which they may test but not as from 14 days of the event scheduled at the circuits. The schedule of such tests and any subsequent amendments must be notified to the Race Direction at least 7 days in advance.

**A non contracted rider (test rider) cannot become a contracted rider during the same season. Waiver may be granted by the Race Direction.**

## **C. Definition of a “contracted rider” and a “Rookie” rider.**

**A contracted rider is a rider designated by the team according article 1.11.1**

**A “Rookie” is a rider nominated by a participating team for participation in the entire season, who has not participated in nine or more events in the same class in any previous season.**

**For the purpose of this clause, the 500cc class and the MotoGP class are considered to be the same.**

### **1.15.1.2 125cc and Moto2 Classes**

Contracted Teams who benefit from **or who have been offered** a Participation Agreement to take part in the Championship are forbidden to practice with those machines:

- i) At any circuit between the 1st December of one year and the **31<sup>st</sup>** January of the following year, both dates being inclusive.
- ii) At any circuit outside the Continental Zone where the team is based, (Europe, Asia/Oceania, Africa, the Americas), between the end of one season and the start of the next season.

- iii) At any circuit included in the Grand Prix calendar of the current year after the date that is 14 days prior to the first race of the season.
- iv) At any circuit included in the Grand Prix calendar of the current year during “breaks”, as defined in 1.15.1 above.

The following exceptions will apply:

- a) Free practice or qualifying practice at the event.
- b) Practice at any circuit after the event at that circuit except during a break as defined above.
- c) Official practice sessions organised by IRTA.
- d) Practice by contracted Teams and their designated riders in those classes, at the two testing circuits designated by each team (see 1.11.1) which may take place up to 14 days before the race scheduled for the circuit, but not during a break as defined above.
- e) Any activity allowed by the Race Direction.
- f) For the Moto2 class, practice at any circuit in the Continental Zone where the team is based during the “winter 2009-2010” only.**
- g) Designated riders who are in their first season of contracted participation in the World Championship may compete in other events held at Grand Prix circuits in Europe during that season.

- v) Practice restrictions do not apply to wild card riders.

### **1.15.1.3 Tyre company testing**

If requested by the tyre manufacturer supplying tyres to the MotoGP class then a two day test must be organized, but not with riders designated by teams, at least four weeks before any event scheduled for a Grand Prix circuit that was not in the Championship of the previous year or that, in the opinion of the Grand Prix Commission, has been substantially resurfaced since the previous event at that circuit.

Any such request must be made at least two months in advance of the test.

Any rider participating in such a test can not participate in the Grand Prix at that circuit.

### **1.15.2 Practice Sessions (warm-up inclusive)**

- i) Riders will commence practice from the pit lane when the green light is displayed at the exit of the pit lane.
- ii) The duration of practice will commence from the illumination of the green light. A visible board or count-down will be shown in the pit lane to indicate the minutes of practice remaining.
- iii) The end of practice will be indicated by the waving of a chequered flag at which time the pit exit will be closed. A rider's time will continue to be recorded until he passes the finish line after the allotted time has elapsed. After the chequered flag, riders complete one additional lap prior to entering the pits.
- iv) If practice is interrupted due to an incident or any other reason, then a red flag will be **waved** at the start line and at all marshals posts. All riders must return slowly to the pit lane. When practice is restarted, the time remaining will be that shown on the monitors of the official timekeepers at the moment the red flags were **waved**.
- v) After practice has started, the condition of the racing surface of the circuit should not be altered except on instruction from the Race Director and the FIM Safety Officer in response to a localised change in conditions.

### 1.15.3 Motorcycles

In the MotoGP class, a rider may practice on two motorcycles providing that all such motorcycles have been **scrutineered** in the name of his/her team.

In the 125cc **and Moto2** classes a rider may practice on the one motorcycle that has been scrutineered in his/her name. 125cc **and Moto2** class rider may change to another motorcycle only in the case of irreparable damage to the principal machine, and only with the permission of the Technical Director who will authorize the issue of a new scrutineering sticker to identify the new machine. The process of authorizing a new machine is not possible during a practice session or after the pit lane closes for the sighting lap of the race.

### 1.15.4. Lap time

All laps of the riders will be timed.

### **1.15.5 Qualification for the Race**

To qualify for the race, a rider must achieve a time at least equal to 107% of the time recorded by the fastest rider of his class.  
Any rider who fails to achieve a qualifying time will be permitted to take part in the race provided that in any of the free practice sessions he/she has achieved a time at least equal to 107% of the fastest rider in same session.

### **1.16 Grid Positions**

**1.16.1** The pole position, allocated to the fastest rider, will be determined during the homologation of the circuit.

**1.16.2** For the MotoGP class, the Grid will be arranged in the 3-3-3-3 configuration "in echelon".  
For the 125cc and Moto2 classes, the Grid will be arranged "in echelon" in the 4-4-4-4 configuration.  
Each line will be offset.  
There will be a distance of 9 metres between each row.

**1.16.3** Grid positions will be based on the fastest time recorded by the riders in all qualifying practice.  
In the case where all qualifying practice have been cancelled, the grid position will be based on the fastest time recorded by the riders in all free practices.

**1.16.4** In the event of a tie, riders' second and subsequent best times will be taken into account.

**1.16.5** The final grid will be published after the warm up has been completed, at the latest one hour before the start of the race.

### **1.17 Races**

**1.17.1** The length of races must be according to the following parameters:

Minimum 95 km

Maximum 130 km

and will be determined by the Permanent Bureau after publication of the calendar.

**1.17.2** The length of a race may only be varied by the Race Direction.

1.17.3 A visible countdown board will be shown at the finish line to indicate the number of remaining laps in the race.

1.17.4 If the Timekeeping rooms are fed by normal power (electricity) supply, they must also be permanently connected to an U.P.S. (Uninterruptible Power System) and to a generator.

## 1.18 Start Procedure

1) Only riders who have completed at least one sighting lap will be permitted to start the race from their position published on the final grid. Under no circumstances may they push onto the grid from the pit lane.

2) Approximately 15 Minutes (20 minutes for MotoGP only, except in the case of a restarted **or rescheduled** race) before the Start of the Race - Pit lane exit opens for sighting laps.

Count-down boards of 5, 4, 3, 2 and 1 minutes are shown at the pit exit.

Riders may complete more than one sighting lap by passing through the pit lane where they may make adjustments, change machines **in MotoGP only** or refuel.

3) Approximately 10 Minutes (15 minutes for MotoGP only, except in the case of a restarted **or rescheduled** race) before the Start of the Race - Pit lane exit closes.

4) Riders who do not go onto the grid may start the warm up lap from the pit lane under the instructions of a marshal positioned at the pit lane exit.

Riders starting the warm up lap from the pit lane must start the race from the back of the grid.

5) When riders reach the grid after the sighting lap(s) they must take up their positions and may be attended by up to five persons (seven for MotoGP), one of whom may hold an umbrella. All attendants on the grid must wear a "Grid Pass". Having taken up their grid position, riders in the MotoGP class only, must take off their helmets, except in the case of a restarted **or wet** race.

Officials will display panels, at the side of the track, indicating the row of the grid, to assist riders in locating their grid position.

6) The Race Director will, at this stage, declare the race as "wet" or "dry" and will indicate this to the riders on the grid and those who may still be in the pit lane by the display of a board. If no board is displayed the race will automatically be "dry".

7) Riders on the grid may at this stage make adjustments to the machine or change tyres to suit the track conditions.  
Tyre warmers may be used on the grid.  
No generators, batteries or electrical supplies are permitted on the grid, except in the MotoGP class.

MotoGP riders may use a generator to power tyre warmers on the grid. Only one generator per machine may be used. The generator must be of the "hand carried" type and have a maximum output capacity of two kilowatts.

Starter engines may also be used on the grid in the **Moto2 and MotoGP classes**.

Generator and starter engines should be located at the rear of the motorcycles.

All adjustments must be completed by the display of the 3 minutes board. After this board is displayed, riders who still wish to make adjustments must push their machine to the pit lane. Such riders and their machines must be clear of the grid and in the pit lane before the display of the 1 minute board, where they may continue to make adjustments or change machine **in MotoGP only**. Such riders will start the warm up lap from the pit lane and will start the race from the back of the grid.

8) Refuelling or changing fuel tank on the grid is forbidden.

9) 5 Minutes Before the Start of the Warm Up Lap - Display of 5 Minute Board on the grid.

10) 3 Minutes Before the Start of the Warm Up Lap - Display of 3 Minute Board on the grid.

Generators must be disconnected and removed from the grid as quickly as possible.

Removal of tyre warmers from machines on the grid.

At this point, all persons other than one mechanic per rider (two in **Moto2 and MotoGP**), the person holding the umbrella for the rider, the television crew of the host broadcaster and essential officials must leave the grid.

The MotoGP riders must put their helmets on.

No person (except essential officials) is allowed to go on the grid at this point.

- 11) 1 Minute Before the Start of the Warm Up Lap - Display of 1 Minute Board on the grid.

At this point, all team personnel except the mechanic(s) will leave the grid. The mechanic(s) will, as quickly as possible, assist the rider to start the machine and will then vacate the grid.

- 12) 30 Seconds Before the Start of the Warm Up Lap - Display of 30 Second Board on the grid.

All riders must be in position on the grid with engines running. No further assistance from mechanics is permitted. Any rider who is unable to start his machine must remove it to the pit lane, under the control of the grid marshals, where he may make further attempts to start it or change machine **in MotoGP**. Such riders may start the warm up lap from the pit lane and will start the race from the back of the grid.

- 13) 2 Minutes Before the Start of the Race - Green flag waved to start warm up lap.

In the interest of safety, should a rider stall his machine, he may be assisted to restart. If, after a reasonable period, the engine does not start, then the rider will be pushed into the pit lane where his mechanics may provide assistance or where the rider may change machine **in MotoGP only**.

The riders will make one lap, at unrestricted speed, followed by a safety car. **The safety car will overtake slow riders.**

As soon as the riders have passed the pit lane exit, the pit lane exit light will be turned green, and any rider waiting in the pit lane will be permitted to join the warm up lap. Thirty seconds later, the light will turn red and a marshal will display a red flag closing the pit lane exit.

On returning to the grid the riders must take up their positions with the front wheel of their motorcycle up to or behind the front line and between the side lines defining the grid position and keep their engines running. If two or more riders must start from the back of the grid, they will take up position in the order in which they qualified for the race.

An official will stand at the front of the grid holding a red flag. Any rider who arrives **after the safety car has taken up its position at the back of the grid** must stop beside the safety car and start the race from there, as directed by a marshal.

Any rider who encounters a problem with his machine on the warm up lap may return to the pit lane and make repairs or change machine **in MotoGP only**.

Any rider who stalls his engine on the grid or who has other difficulties must remain on the motorcycle and raise an arm. It is not permitted to attempt to delay the start by any other means.

As each row of the grid is completed, the officials will lower the panels indicating that their row is complete. Panels will not be lowered when a rider in that row has indicated that he has stalled his motorcycle or has other difficulties. When all panels have been lowered and the safety car has **taken up its position**, an official at the rear of the grid will wave a green flag.

The Starter will then instruct the official at the front of the grid, displaying the red flag, to walk to the side of the track.

- 14) A red light will be displayed for between 2 and 5 seconds. The red light will go out to start the race

A safety car will follow behind the motorcycles for the whole of the first lap. **The safety car will overtake slow riders.**

If the red lights' device is fed by normal power (electricity) supply, it must also be connected to a set of car batteries or to an U.P.S. (Uninterruptible Power System) to provide power to the starting lights' device if the electric line breaks down just at the moment of the start.

Any rider who anticipates the start will be required to carry out the ride through described under article 1.19.

Anticipation of the start is defined by the motorcycle moving forward when the red lights are on. The Race Direction will decide if a penalty will be imposed and must arrange for the team to be notified of such penalty before the end of the fourth lap.

- 15) If, after the start of the race, a rider stalls his machine, then he may be assisted by being pushed along the track until the engine starts.  
If, after a reasonable period, the engine does not start, then the rider will be pushed into the pit lane, where his mechanics may provide assistance or where the rider may change machine **in MotoGP only**.
- 16) After the riders have passed the exit of the pit lane, the official situated at this exit will display a green light to start any riders still in the pit lane.
- 17) Unless the race is interrupted, after the leading rider has passed the finish line at the end of his first lap, no further changes of machines are permitted. After this time, in the MotoGP class only, the 2 following procedures will apply:
  - If the race has been declared wet (Art. 1.20), changing from a machine equipped with a rain tyre to a machine equipped with an intermediate or slick tyre, changing from a machine equipped with an intermediate tyre to a machine equipped with a rain or a slick tyre, and changing from a machine equipped with a slick tyre to a machine equipped with an intermediate or a rain tyre is permitted at any time during the race. **For change of machines at least one tyre must be different (slick vs. intermediate vs. wet).**
  - If the race has not been declared wet (Art. 1.20), the same machine changes as mentioned above are permitted only after the white flags have been displayed around the track.In both cases, tyre warmers, changing tyres and adjustments are permitted on the machine in the pits and in the pit-lane.  
The spare machine may remain inside the pit box until such time as it is used in the race, but any exchange of machine must be made in the pit lane.
- 18) Should there be a problem that might prejudice safety, then the Starter will display a flashing yellow light and the board "Start Delayed" and a marshal will wave a yellow flag at each row of the starting grid from the signalling platform. The start procedure will be re-commenced at the 1 minute board stage, the riders will complete an additional warm up lap and the race distance will be reduced by one lap.  
Any person who, due to his behaviour on the grid is responsible for a "start delayed", may be penalised with one of the following penalties:

fine – ride through - disqualification - withdrawal of Championship points.

### **1.19 Ride Through Procedure**

During the race, the rider will be requested to ride through the pit lane. Stopping is not permitted. He may then rejoin the race.

The rider must respect the speed limit (Art. 1.21.14), in the pit lane. In case of infraction of this speed limit, the ride through procedure will be repeated; in case of a second infraction of this speed limit, the black flag will be shown to the rider.

In the event of a restarted race, the above regulation will also apply. In the case of a race interrupted prior to the penalty being complied with and if there is a second part, the rider will be required to ride through after the start of the second part of the race.

In the case of a rider carrying forward a penalty for anticipation of the start, into the second part of an interrupted race and subsequently found to have anticipated the second start, the rider will be shown the black flag.

After notification has been made to the team, a yellow board (100cm horizontal X 80 cm vertical) displaying the riders' numbers (black colour) will be shown at the finish line and the information will also be displayed on the timekeeping monitors.

Failure by the relevant rider to ride through, having been shown the board 5 times, will result in that rider being shown the black flag.

In the case where the organisation has been unable to carry out the ride through penalty before the end of the race, the relevant rider will be inflicted with a time penalty of 20 seconds.

### **1.20 "Wet" and "Dry" Races**

All races will be categorised as either wet or dry. A board may be displayed on the grid to indicate the status of the race. If no board is displayed, the race is automatically dry. The purpose of this classification is to indicate to riders the consequence of varying climatic conditions during a race.

## **1.20.1 125 and Moto2 races**

- 1.20.1.1 Dry Races – a race classified as dry will be interrupted by the Race Director, if he considers that climatic conditions affecting the surface of the track makes it likely that riders will wish to change tyres.
- 1.20.1.2 Wet Races – a race classified as wet, usually commenced in varying or wet conditions, will not be interrupted for climatic reasons and riders who wish to change tyres or make adjustments must enter the pits and do so during the actual race.
- 1.20.1.3 In all cases where the first race is interrupted for climatic reasons, then the restart will automatically be a “wet” race.

## **1.20.2 MotoGP race**

A race will not be interrupted for climatic reasons and riders who wish to change machine (when allowed), tyres or make adjustments must enter the pits and do so during the actual race.

## **1.21 Behaviour During Practice and Race**

- 1) Riders must obey the flag signals, the light signals, and the boards which convey instructions. Any infringement to this rule will be penalised according to the provisions of article 1.22.
- 2) Riders must ride in a responsible manner which does not cause danger to other competitors or participants, either on the track or in the pit-lane. Any infringement of this rule will be penalised with one of the following penalties: time penalty – fine – ride through - disqualification - withdrawal of Championship points - suspension.
- 3) Riders should use only the track and the pit-lane. However, if a rider accidentally leaves the track then he may rejoin it at the place indicated by the marshals or at a place which does not provide an advantage to him. Any infringement of this rule during the practices or warm up will be penalised by the cancellation of the lap time concerned and during the race, by a ride through. Further penalties (such as fine – disqualification - withdrawal of Championship points) may also be imposed
- 4) Any repairs or adjustments along the race track must be made by the rider working alone with absolutely no outside assistance. The

marshals may assist the rider to the extent of helping him to lift the machine and holding it whilst any repairs or adjustments are made. The marshal may then assist him to re-start the machine.

- 5) If the rider intends to retire, then he must park his motorcycle in a safe area as indicated by the marshals.
- 6) If the rider encounters a problem with the machine which will result in his retirement from the practice or the race, then he should not attempt to tour at reduced speed to the pits but should pull off the track and park his machine in a safe place as indicated by the marshals.
- 7) Riders who are returning slowly to the pits for remedial work should ensure that they travel as far as possible off the racing line.
- 8) Riders may enter the pits during the race, but taking the motorcycle inside the pit box is not permitted. In the MotoGP class, in the case of an exchange of machine during a race (Art. 1.18.17), if a machine that has been active in the race enters the pit box, this machine is deemed to be retired and may not be used again in the race.  
Refuelling is strictly prohibited.  
Any infringement of this rule will be penalised with a disqualification.
- 9) Riders who stop their engines in the pits may be assisted to re-start their motorcycle by the mechanics.
- 10) Riders are not allowed to transport another person on their machine or to be transported by another rider on his machine (exception: Another rider or by another rider after the chequered flag or red flag).
- 11) Riders must not ride or push their motorcycles in the opposite direction of the circuit, either on the track or in the pit lane, unless doing so under the direction of an Official.
- 12) No signal of any kind may pass between a moving motorcycle and the rider's team, or anyone connected with the motorcycle's team, entrant or rider, except for the signals of the timekeeping transponder, lap trigger, GPS, legible messages on a pit board, or body movements by the rider or team. Onboard TV camera signals are allowed, but only when such signals are for the purposes of and managed by the Championship promoter.
- 13) **All machines are required to carry onboard camera(s) if requested by the organiser.**

The cameras and associated equipment must be carried during all practice sessions and the race.

Cameras and other equipment, will be supplied to the designated Teams by, at the latest, 14h00 on the day preceding the first day of practice at an event.

Teams must give reasonable access and assistance to the company designated for the supply of the camera equipment to facilitate the mounting of the equipment.

- 14) A speed limit of 60 km/h will be enforced in the pit lane at all times during the event. Riders must respect the speed limit from where the sign 60 km/h is placed up to where the sign 60 Km/h crossed out is placed.

Any rider found to have exceeded the limit during the practice will be subject to a fine of **70 €** for the first offence, and **370 €** for subsequent offences at the same event.

Any rider who exceeds the pit lane speed limit during a race will be penalised with a ride through.

The Race Direction must communicate the offence to the pit of the rider after having received the information from the Official in charge.

- 15) Stopping on the track during practices and races is forbidden.
- 16) During the practice sessions and warm ups, practice starts are permitted, when it is safe to do so, at the pit lane exit before joining the track **and after passing the chequered flag** at the end of practice sessions and warm-ups when it is safe to do so, off the racing line.
- 17) If the winning rider wishes to parade a flag, he must ride to the side of the racing surface to collect the flag and then rejoin the circuit when it is safe to do so.
- 18) It is not permitted to ride racing motorcycles within the circuit other than in the pit lane or on the track.
- 19) After the chequered flag, riders riding on the track must wear a safety helmet until they stop on the pit lane / parc fermé.
- 20) Penalties for infringement of article 2.3.7 (Engine durability in MotoGP).**

- **Infringement before the race: the rider will start the race from the pit lane ~~20''~~ 10'' after the start of the race.**
- **Infringement during the race: ride through.**

## 1.22 **Flags and Lights**

Marshals and other officials display flags or lights to provide information and/or convey instructions to the riders:

### 1.22.1 **Flags and Lights Used to Provide Information:**

- **Green Flag**

The track is clear

This flag must be shown motionless at each flag marshal post for the first lap of each practice session and of the warm up, for the sighting lap(s) and for the warm up lap.

This flag must be shown motionless at the flag marshal post immediately after the incident that necessitated the use of one or more yellow flags.

This flag must be waved by the starter to signal the start of the warm up lap.

When the pit-lane exit is open, this flag must be waved at the pit-lane exit.

- **Yellow and Red Striped Flag**

The adhesion on this section of the track could be affected by any reason other than rain.

This flag must be shown motionless at the flag marshal post.

- **White Flag with diagonal red cross**

Drops of rain on this section of the track.

This flag must be shown motionless at the flag marshal post.

- **White Flag with diagonal red cross + Yellow and Red Striped Flag**

Rain on this section of the track.

These flags must be shown together motionless at the flag marshal post.

- **Blue Flag**

Shown waved at the flag marshal post, this flag indicates to a rider that he is about to be overtaken.

During the practice sessions, the rider concerned must keep his line and slow down gradually to allow the faster rider to pass him.

During the race, the rider concerned is about to be lapped. He must allow the following rider(s) to pass him at the earliest opportunity. Any infringement of this rule will be penalised with one of the following penalties: fine - disqualification - withdrawal of Championship points. At all times, this flag will be shown waved to a rider leaving the pit lane if traffic is approaching on the track.

- **Chequered Black / White Flag**

This flag will be waved at the finish line on track level to indicate the finish of race or practice session.

- **Chequered Black / White Flag and Blue Flag**

The chequered black/white flag will be waved together with the blue flag presented motionless at the finish line on track level when a rider(s) precedes closely the leader during the final lap before the finish line (see art. 1.24.1).

- **Green Light**

This light must be switched on at the pit lane exit to signal the start of each practice session and of the warm up, the start of the sighting lap(s) and the start of the warm up lap.

- **Flashing Blue Lights**

Will be switched on at the pit lane exit at all time during practices and races.

## **1.22.2 Flags Which Convey Information and Instructions:**

- **Yellow Flag**

Shown waved at each row of the starting grid, this flag indicates that the start of the race is delayed.

Shown waved at the flag marshal post, this flag indicates that there is a danger ahead. The riders must slow down and be prepared to stop. Overtaking is forbidden up until the point where the green flag is shown.

Any infringement of this rule during a practice session will result in the cancellation of the time of the lap during which the infraction occurred. In case of infringement of this rule during the race, the rider must go back the number of positions decided by the Race Direction. The penalty will be first communicated to the team and then a board will be displayed for the rider on the finish line during a maximum of 5 laps. If the rider did not go back after the board has been presented 5 times, he will be penalized by a ride through.

In both cases, further penalties (such as fine - suspension) may also be imposed.

If immediately after having overtaken, the rider realises that he did an infraction, he must raise his hand and let pass the rider(s) that he has overtaken. In this case, no penalty will be imposed.

During the final inspection lap, this flag must be waved at the exact place where the flag marshal will be positioned during the practices, the warm ups and races.

- **White Flag**

Waved at the flag marshal post during the race, this flag indicates that the riders are allowed to change machine.

Only the Race Direction can take the decision.

- **Red Flag and Red Lights**

When the race or practice is being interrupted, the red flag will be waved at each flag marshal post and the red lights around the track will be switched on. Riders must return slowly to the pits.

When the pit-lane exit is closed, this flag will be shown motionless at the pit-lane exit and the light will be switched on. Riders are not allowed to exit the pit lane.

Any infringement of this rule will be penalised with one of the following penalties: fine - disqualification - withdrawal of Championship points - suspension.

At the end of each practice session and warm-up, a red light will be switched on at the finish line.

The red flag will be shown motionless on the starting grid at the end of the sighting lap(s) and at the end of the warm up lap.

The red flag may also be used to close the track.

The red lights will be switched on at the start line for between 2 and 5 seconds to start each race.

- **Black Flag**

This flag is used to convey instructions to one rider only and is displayed motionless at each flag marshal post together with the rider's number. The rider must stop at the pits at the end of the current lap and cannot restart.

This flag will be presented only after the rider's team has been notified. Any infringement of this rule will be penalised with one of the following penalties: fine - withdrawal of Championship points - suspension.

- **Black Flag with orange disk (Ø 40 cm)**

This flag is used to convey instructions to one rider only and is displayed motionless at each flag marshal post together with the rider's number. This flag informs the rider that his motorcycle has mechanical problems likely to endanger himself or others, and that he must immediately leave the track.

Any infringement of this rule will be penalised with one of the following penalties: fine - withdrawal of Championship points - suspension.

### **1.22.3 Flag Dimension**

The flag dimension should be 80cms in the vertical and 100cms in the horizontal.

The flag dimension will be checked the day preceding the day of the first practice session.

### **1.22.4 Flag Colour**

The Pantones for the colours are as follows :

Orange : Pantone 151C  
Black : Pantone Black C  
Blue : Pantone 286C or 298C  
Red : Pantone 186C  
Yellow : Pantone Yellow C  
Green : Pantone 348C

The flags' colours will be checked the day preceding the day of the first practice session.

### **1.22.5 Rider' s number board**

Black board (70 cm horizontal X 50 cm vertical) which enables the race number of a rider to be attached with a set of numbers in white, whose stroke width is minimum 4 cm and height minimum 30 cm. This board must be available at each flag marshal post.

### **1.22.6 Flags Marshals posts**

The location will be fixed during the circuit homologation.

### **1.22.7 Marshals Uniforms**

It is strongly recommended the marshals' uniforms to be in white or orange (Ref. Pantone: 151C) and the rain coat to be transparent.

## **1.23 Medical cars**

The medical cars must be equipped with yellow flashing lights. The words "MEDICAL" should be clearly indicated on the back and the sides of the car.

## **1.24 Finish of a Race and Race Results**

1.24.1 When the leading rider has completed the designated number of laps for the race, he will be shown a chequered flag by an official standing at the finish line, at track level. The chequered flag will continue to be displayed to the subsequent riders.

When the chequered flag is shown to the leading rider, no other rider will be permitted to enter the track from the pit lane.

As soon as the chequered flag is shown to the leading rider, the red light will be switched on at the pit lane exit and a marshal showing a red flag will stand in the pit lane exit.

If a rider(s) closely precedes the leader during the final lap before the finish line, the official will show to the rider(s) and to the leader simultaneously the Chequered flag and the Blue flag. That means that the race is finished for the leader while the rider(s) closely preceding the leader has (have) to complete the final lap and take the Chequered flag.

1.24.2 In case of a photo-finish between two, or more, riders, the decision shall be taken in favour of the competitor whose front wheel leading edge crosses the plane of the finish line first. In case of ties, the riders concerned will be ranked in the order of the best lap time made during the race.

1.24.3 The results will be based on the order in which the riders cross the line and the number of laps completed.

1.24.4 To be counted as a finisher in the race and be included in the results a rider must:

a - Complete 75% of the race distance.

b - Cross the finish line on the race track (not in the pit lane) within five minutes of the race winner. The rider must be in contact with his machine.

1.24.5 The riders placed in the first three positions in the race will be escorted by officials, as quickly as possible, to the podium for the awards ceremony. Participation in the podium ceremony by the first three riders is compulsory.

1.24.6 A new lap record for a circuit can only be established by a rider during a race.

1.24.7 Both for practice and for race, the lap time is the subtraction of the time between two consecutive crossings of the finish line painted on the track.

## **1.25 Interruption of a race**

1.25.1 If the Race Director decides to interrupt a race, then red flags will be displayed at the finish line and at all marshals' posts and he will switch on the red lights around the circuit. Riders must immediately slow down and return to the pit lane.

The results will be the results taken at the last point where the leader and all other riders on the same lap as the leader had completed a full lap without the red flag being displayed

Exception: if the race is interrupted after the chequered flag, the following procedure will apply:

1) For all the riders to whom the chequered flag was shown before the interruption, a partial classification will be established at the end of the last lap of the race.

2) For all the riders to whom the chequered flag was not shown before the interruption, a partial classification will be established at the end of the penultimate lap of the race.

3) The complete classification will be established by combining both partial classifications as per the lap/time procedure.

At the time the red flag is displayed, riders who are not actively competing in the race will not be classified.

Within 5 minutes after the red flag has been displayed, riders who have not entered the pit lane, riding on their motorcycle, will not be classified.

- 1.25.2 If the results calculated show that less than three laps have been completed by the leader of the race and by all other riders on the same lap as the leader, then the race will be null and void and a completely new race will be run.  
If it is found impossible to re-start the race, then it will be declared cancelled and the race will not count for the Championship.
- 1.25.3 If three laps or more have been completed by the leader of the race and all other riders on the same lap as the leader, but less than two-thirds of the original race distance, rounded down to the nearest whole number of laps, then the race will be restarted according to Art. 1.26. If it is found impossible to restart the race, then the results will count and half points will be awarded in the Championship.
- 1.25.4 If the results calculated show that two-thirds of the original race distance rounded down to the nearest whole number of laps have been completed by the leader of the race and by all other riders on the same lap as the leader, then for the 125cc and Moto2 classes the race will be deemed to have been completed and full Championship points will be awarded. For the MotoGP class, the race will be restarted for a minimum of 5 laps according to Art. 1.26.  
If it is found impossible to restart the race, then the results will count and full Championship points will be awarded.

## **1.26 Re-Starting a race that has been interrupted**

- 1.26.1 If a race has to be re-started, then it will be done as quickly as possible, consistent with track conditions allowing. As soon as the riders have returned to the pits the Clerk of the Course will announce a time for the new start procedure to begin which, conditions permitting, should not be later than 10 minutes after the initial display of the red flag.
- 1.26.2 The results of the first race must be available to teams before the second part of a race can be started.
- 1.26.3 The start procedure will be identical to a normal start with sighting laps, warm-up lap, etc.
- 1.26.4 Conditions for the re-started race will be as follows:

- i) In the case of situation described in 1.25.2 (less than 3 laps completed) above:
  - a. All riders may re-start.
  - b. Motorcycles may be repaired or changed. Refuelling is permitted.
  - c. - For 125 and Moto2, the number of laps will be two-thirds of the original race distance rounded down to the nearest whole number of laps.  
- For MotoGP, the number of laps will be the same as the original race distance.
  - d. The grid positions will be as for the original race.
  
- ii) In the case of situation described in 1.25.3 (3 laps or more and less than two-thirds completed) and 1.25.4 (two-thirds completed for MotoGP only) above:
  - a. Only riders who are classified as finishers in the first race may re-start.
  - b. Motorcycles may be repaired or changed. Refuelling is permitted.
  - c. - For 125 and Moto2, the number of laps of the second race will be the number of laps required to complete two-thirds of the original race distance rounded down to the nearest whole number of laps with a minimum of 5 laps.  
- For MotoGP, the number of laps of the second race will be the number of laps required to complete the original race distance with a minimum of 5 laps.
  - d. The grid position will be based on the finishing order of the first race.
  - e. The final race classification will be established according to the position and the consolidated number of laps of each rider at the time he crossed the finish line at the end of the last part of the race. Provisions of Art. 1.24.4 will apply.

## **1.27 Check Area**

At the end of the race, or the final part of a race that has been interrupted, the first three motorcycles plus any other motorcycles specified by the Technical Director, must be removed to a check area pending inspection by the Technical Scrutineers or potential protests. Machines will normally be released from the check area 60 minutes after the finish of the race.

## **1.28 Championship Points and Classification**

1.28.1 Riders and Constructors will compete for the FIM Road Racing World Championship Grand Prix.  
Teams will compete for a MotoGP Team Championship.

1.28.2 For riders, the points will be those gained in each race.

1.28.3 For Constructors, only the highest placed motorcycle of a Constructor will gain points, according to the position in the race.

1.28.4 Teams in the MotoGP class will, in principle, be comprised of two riders. The names of the teams will be composed of three elements :

1. The name of the Manufacturer of the motorcycle or engine. (Mandatory).
2. The name of the Team. (Mandatory except where the Team name is the same as the Manufacturer).
3. The name of one principal Sponsor. (Optional).

Teams will compete for a Championship. All points scored by both riders in the Team, including substitutes or replacements, will count towards the Team Championship.

In the case of a one rider Team then only the points scored by that rider will count towards the Team Championship.

Wild card riders will not score points for the Team Championship.

1.28.5 For each race, Championship points will be awarded on the following scale:

|                 |           |
|-----------------|-----------|
| 1 <sup>st</sup> | 25 points |
| 2 <sup>nd</sup> | 20 points |
| 3 <sup>rd</sup> | 16 points |
| 4 <sup>th</sup> | 13 points |

|                  |           |
|------------------|-----------|
| 5 <sup>th</sup>  | 11 points |
| 6 <sup>th</sup>  | 10 points |
| 7 <sup>th</sup>  | 9 points  |
| 8 <sup>th</sup>  | 8 points  |
| 9 <sup>th</sup>  | 7 points  |
| 10 <sup>th</sup> | 6 points  |
| 11 <sup>th</sup> | 5 points  |
| 12 <sup>th</sup> | 4 points  |
| 13 <sup>th</sup> | 3 points  |
| 14 <sup>th</sup> | 2 points  |
| 15 <sup>th</sup> | 1 point   |

1.28.6 All races will count for the Championship classification.

1.28.7 In the event of a tie in the number of points, the final positions will be decided on the basis of the number of best results in the races (number of first places, number of second places etc.). In the event that there is still a tie then, the date in the Championship at which the highest place was achieved will be taken into account with precedence going to the latest result.

1.28.8 The World Champions in each category are obliged to attend an official FIM ceremony.

## **1.29 Instructions and Communications to Competitors**

1.29.1 Instructions may be given by the Race Director and/or Clerk of the Course to Teams and/or Riders by means of special circulars in accordance with the Regulations. Circulars will be posted on the official notice board and placed in the special team mail box which will be provided by IRTA at each Event. Posting **on the official notice board and placing** in the team mail box will be deemed as proof of delivery.

1.29.2 All classifications and results of practice and the race, as well as all decisions issued by the officials, will be posted on the official notice board.

**Posting on the official notice board will be deemed as proof of delivery and official publication.**

1.29.3 Any communication from the Race Direction, the Permanent Officials or the Clerk of the Course to a team or rider must be communicated in writing. Similarly, any communication from a team or rider to the Race

Direction, the Permanent Officials or the Clerk of the Course must also be made in writing.

### **1.30 Team personnel in the pit lane**

For safety reasons, the following rules must be strictly respected.

- 1.30.1 Team personnel will not be permitted in the pit lane during practices, warm-up and race of another class unless they are making adjustments to their motorcycle.
- 1.30.2 The maximum number of team personnel per rider in the working area in front of the pits is limited to 8 for MotoGP and 6 for 125 and Moto2.
- 1.30.3 The maximum number of team personnel per rider on the signalling platform is limited to 4 for all the classes.

## 2. TECHNICAL REGULATIONS

**Specifically for the Moto2 class these regulations derogate and supersede the technical regulations published in December 2008.**

### 2.1 Introduction

2.1.1 The Championship is for motorcycles, i.e. vehicles with two wheels that make one track propelled by an internal combustion engine, controlled by one rider.

2.1.2 Providing that the following Regulations are complied with, the constructors are free to be innovative with regard to design, materials and overall construction of the motorcycle.

### 2.2 Classes

The following classes will be accommodated, which will be designated by engine capacity:

125 Over 80cc up to 125cc - Maximum one cylinder

**Moto2 Moto2 Official Engine**

MotoGP Up to 800cc – Unlimited cylinders **4-stroke only**

Motorcycles participating in the MotoGP class must be prototypes. Those that are not entered by a member of MSMA must be approved for participation by the Grand Prix Commission.

### 2.3 Engines

2.3.1 Engines may operate on the two stroke or four stroke principle only. For MotoGP, only 4 stroke engines are permitted. The normal section of each engine cylinder and piston in plan view must be circular. Circular section cylinders & pistons are defined as having less than 5% difference in the diameter measured at any two points.

2.3.2 Engines must be normally aspirated.

2.3.3 Cubic capacity of the engine will be defined by the swept volume of the cylinder, i.e. the area of the bore of the cylinder multiplied by the stroke.

2.3.4 No tolerance on capacities is permitted.

2.3.5 Engine capacity must be measured at ambient temperature.

### **2.3.6 Moto2 class Engines**

#### **Engine Supply**

**1) Only engines from the official Supplier are allowed to be used. The term official Supplier shall refer to the engine producer and/or to the company nominated to perform such functions as engine assembling, rebuilding, maintenance, and logistics.**

**2) Sealed engines will be provided to each team, allocated on a random basis by the Technical Director and staff.**

**3) Security seals may not be removed or broken and the team may not open the engine, except to remove unsealed covers for maintenance as described in Art 2.3.6. 4) specifically the cam cover, cylinder head, cylinders, crankcase, may not be opened or removed.**

**4) Teams may only perform maintenance of parts specifically authorised by the Championship Organisers which does not involve removal of security seals. This includes change of oil and external items as detailed in the following articles including cooling, fuel and electrical systems, and clutch parts including plates, hubs, control mechanisms.**

**5) All other maintenance and repair, specifically that involving removal of security seals will be carried out by the official Supplier. Regular maintenance, rebuilding and replacement of engines will be at the sole discretion of the Championship Organisers, and on a schedule determined by them.**

**6) Engines returned for maintenance, repair or replacement must be in the original condition as delivered, that is with the original fittings in place as required by the Championship Organiser, which may include:**

- covers, cooling system including hoses and connectors, electrical system including wiring and connectors, clutch.**

7) In the case of engine breakdown or damage, another engine may be allocated by the Technical Director. Such allocation can not be made during a Moto2 practice session or within 30 minutes of the pit lane being opened for the race sighting lap.

#### Engine Definition, Specification and Modification

8) i) Use of the complete engine is mandatory, and it may not be modified in any way except as specifically described in these regulations.

ii) The engine design and specification will be determined by the official Supplier in consultation with the Organisers. The engine design and specification may be changed at any time with the agreement of both the official Supplier and the series Organiser. New technologies (for example; materials, cylinder head and valve design, valve operating mechanisms, alternative fuels, etc.) are encouraged provided they meet the Series' principle of cost reduction and long-term cost control, and are agreed by the official Supplier and series Organiser.

iii) The official Supplier may change the specification of individual parts from time to time, as is normal to improve reliability and function.

iv) All engines supplied to teams must be equal in specification and **the engine performance, as measured by the official Supplier under their standard dynamometer conditions, must be within the tolerance range agreed by the Organiser and the official Supplier.**

~~v) A team may request a replacement engine on the grounds of substandard performance. Such request must be made in writing to the Technical Director accompanied by a deposit of €20,000 per engine paid to IRTA. If the Technical Director is satisfied that there is clear evidence of substandard performance a replacement engine may be issued with the approval of the Race Direction for the next race event. The original engine will be returned to the official Supplier at the end of the race event where the complaint is lodged to be tested under standard conditions by the official Supplier and the dynamometer report sent to the Technical Director. If the engine is deemed within specified performance parameters and fit for use, the same engine will be returned to the team for the following race and the team's deposit will be forfeited. If the engine is deemed to be outside of specified performance parameters and not fit for use, a replacement engine will be issued for the next race and the deposit will be returned to the team in full.~~

**v) A team may request a replacement engine on the grounds of substandard performance.**

**a) If the Technical Director is satisfied that there is clear evidence of an engine problem causing substandard performance a replacement engine may be issued under Art. 2.3.6.7. with the approval of Race Direction.**

**b) If the Technical Director determines that there is no clear evidence of an engine problem, the team may still request a replacement engine.**

**Such request must be made in writing to the Technical Director accompanied by a deposit of €20,000 per engine paid to IRTA.**

**The engine may be replaced with the approval of Race Direction, and the original engine will be returned to the official Supplier to be tested under standard conditions by the official Supplier and the dynamometer report sent to the Technical Director.**

**If the engine is deemed to be within specified performance parameters and fit for use, the same engine may be returned to the team at a subsequent race and the team's deposit will be forfeited.**

**If the engine is deemed to be outside of specified performance parameters and not fit for use, the deposit will be returned to the team in full.**

*(Grand Prix Commission 25/06/2010)*

**vi) The complete engine ('engine' in these regulations) is defined as the supplied engine cases, covers and everything contained within, and including the following external parts supplied by the official Supplier:**

**a) Fuel system including airbox, air filter, fuel pump & regulator, throttle bodies, intake manifolds, air intake funnels, fuel injectors primary & secondary, fuel delivery lines and hoses.**

**b) Electrical system including generator, ignition coils, ECU (engine electronic control unit).**

**c) Lubrication system including oil filter, oil cooler, oil pressure switch.**

9) To ensure reliability and performance, the official Supplier does not recommend any changes to the engine. However at the Team's risk the following items may be replaced and/or modified:

a) Coolant hoses and fittings may be changed to suit individual radiator designs. Where an inlet/outlet pipe fitting is changed it must have the same internal diameter as the original part.

b) The fuel delivery line between the fuel pump and the primary injectors may be modified to adjust the length and/or to fit a connector in-line.

10) The following external items may not be replaced, removed or modified, except if replaced with an original part due to malfunction or damage (as authorised by the Technical Director):

a) Water pump

b) Oil cooler (heat exchanger)

c) Oil filter

d) Oil pressure sensor

e) Gearbox output speed sensor

f) Water temperature sensor

g) Electrical cables and connectors supplied as part of the engine

#### Cooling System

11) Design and construction of the cooling system is free, provided it complies with Articles 2.3.6. 9) and 2.3.6. 10), and Article 2.3.6.15) ensuring that the engine meets the operating parameters specified by the official Supplier (refer to Table 2 in the Appendix).

12) The standard engine oil cooler is mandatory, and additional oil coolers are not permitted.

#### Engine Use

13) The engine may be used only at official Moto2 events as defined by the Championship Organisers. Moto2 events include Official Tests and Grand Prix race events.

14) The Championship Organisers may require that engines are returned at the completion of certain events and/or maintenance period (Art. 2.3.6. 5). This is at the sole discretion of the Championship Organisers, and Teams must comply with such requests.

15) The engine must be used at all times respecting the range of operating parameters provided by the official Supplier, and avoiding deliberate misuse. Refer to Table 2 in the Appendix.

#### **Ignition and Electronics**

16) Only the electronic ignition/fuel injection control units (ECU) supplied by the official Supplier are allowed.

This ECU must remain unmodified in hardware and software as delivered by the official Supplier, with the exception of the normal tuning adjustments allowed only by the standard software 'Setting Tool' supplied as part of the Moto2 Kit.

17) The ECU is defined as part of the engine (refer to Art. 2.3.6.8. b)). ECU units may be distributed to teams at official Moto2 events, and may be required to be returned during or after the event for checking and/or re-distribution.

18) The Technical Director may inspect all ECU hardware and software at any time, including access to all stored information. The Technical Director may require the team to change the ECU on any machine for another identical standard one at any time.

19) Design and construction of the wiring harness is free to accommodate the needs of different machine designs, provided it respects the official Supplier's wiring diagram. Only the standard ECU, Datalogger and junction units may be connected to the harness, and connection of the components listed in Art. 2.3.6. 8 and 2.3.6.10 is mandatory.

#### **Datalogger**

20) Only the standard Moto2 Datalogger system (including hardware, sensors and firmware) approved by the Championship Organiser is allowed to be used at official Moto2 race and test events. PC software is not controlled.

21) The Technical Director may inspect and access the datalogger system at any time, including the reading and downloading of data. Team data, with the exception of engine performance data, will be treated as confidential. The Technical Director may require the team to change the datalogger for another identical standard one at any time.

22) The Moto2 Datalogger will be supplied with a standard sensor package. There are additional logger channels available for

optional sensors. No other sensors are permitted on the machine at official Moto2 events. Refer to Table 1 in the Appendix.

### 2.3.7 Engine Durability

1.) In the MotoGP class the number of engines available for use by each rider is limited. For the 2010 season a maximum of 6 engines may be used by each permanent contracted rider for all the scheduled races of the season. Should a rider be replaced for any reason, the replacement rider will be deemed to be the original rider for purposes of engine allocation.

Each manufacturer is allowed 2 additional engines for the exclusive use of Wild Card riders only.

**For 2010, the manufacturer members of MSMA who did not win at least 2 dry races in 2008 + 2009 seasons can use 9 engines instead of 6.**

*(Grand Prix Commission 14/08/2010)*

2.) The engines available for the exclusive use of each rider must be marked and sealed by the Technical Director prior to first use. It is the Team's obligation to register any new engine with the Technical Director prior to use. Once registered and used for the first time, engines may not be swapped between riders, even within the same team. A new engine is deemed to be used when the motorcycle with that engine crosses the transponder timing point at the pit lane exit.

3.) The engines will be sealed by means of wiring and identification tabs, so that:

- a. the timing system is not accessible (e.g. the head cover must be wired to the cylinder head),
- b. the timing driving system is not accessible (e.g. the gear train/chain cover is wired so that it cannot be removed),
- c. the cylinder head and the cylinders block (if any) cannot be removed from the engine (e.g. the cylinder head is wired to the cylinders block and the cylinders block is wired to the engine crankcase),
- d. the crankcase cannot be opened (e.g. the crankcase halves are wired together).

All the parts that are accessible without removing the sealing wiring can be replaced. Breaking or removing the seal or wiring without supervision by the Technical Director will be deemed to be “engine rebuilding” and engines with broken, tampered with or missing security seals will be treated as a new engine in the allocation.

4.) Should a competitor, for any reason (e.g. mechanical failure, crash major damage, etc.) require the use of another engine above their allocation, the Technical Director must be informed before the new engine is used, and Race Direction will apply the appropriate penalty according to the Sporting Regulations. The damaged engine will be removed from the allocation and if it is used again, it will be treated as a new engine with the appropriate penalty.

5.) There is no limit to the number of times a sealed, allocated engine can be fitted to and used in a motorcycle, provided the security seal is not broken or removed. Replacing an engine with another sealed engine (new or used) from the rider’s allocation is allowed with no penalty.

6.) To prevent the running of a used, allocated engine outside of MotoGP events, all allocated engines will have security seals placed over either exhaust or inlet ports (on at least one cylinder bank, in the case of V-type engines) before leaving the circuit. Teams wishing to re-use such an allocated and sealed engine must request the Technical Director to remove the security seals. If the Technical Director or his staff finds that the security seals are not intact, the engine will be deemed to be a new engine in the allocation, with the appropriate penalty.

## **2.3.8 Control Systems**

2.3.8.1 In the MotoGP class, the use of hydraulic and/or pneumatic pressurized powered systems is not allowed, with the exception of cylinder inlet/exhaust valve springs. All hydraulic systems on the motorcycle must be powered only by the rider’s manual inputs.

Normal hydraulic hand/foot controls such as master/slave cylinders for brakes/clutch are allowed. Pneumatic engine valve actuating systems are allowed. Oil/water pumps for engine lubricating/cooling are allowed.

The use of engine lubricating oil for any purpose other than lubrication and cooling (such as powered hydraulic systems) is not allowed.

In the case of a new manufacturer who has never participated in the MotoGP class prior to 1.1.2010, this regulation will apply only from 1.1.2011.

**2.3.8.2** In the MotoGP class, variable valve timing and variable valve lift systems, driven by hydraulic and/or electric/electronic systems are not permitted.

### **2.3.9 Fuel System**

~~**2.3.9.1** In the MotoGP class the maximum permitted fuel pressure is 10 Bar.~~

#### **2.3.9.2 Moto2 class fuel system**

1) Use of the fuel system (as described in Article 2.3.6.8. a)) from the official Supplier is mandatory, and it must remain standard, as delivered by the official Supplier. The only modifications permitted are those specifically described in these regulations. The Technical Director may require the team to exchange any parts of the fuel system for another standard part, at any time.

2) **Fuel Pump**: The fuel tank gauge assembly (ie. float, arm and support bracket) of the standard fuel pump may be removed.

3) **Fuel Tank**: Design and construction of the fuel tank is free, within the constraints of the FIM Grand Prix Regulations, Art. 2.6. There are no capacity restrictions.

4) **Fuel Delivery Hoses**: Fuel delivery hose fittings must remain standard, as supplied. However it is permitted to fit quick - connectors (eg. "dry-break" connectors) in the fuel lines.

5) **Airbox**: Only the standard airbox supplied by the official Supplier (including air filter and secondary injectors) may be used. No modifications, alterations or additions to this airbox are allowed, except as described in Art. 2.3.9.2. 6)

6) To ensure correct performance the official Supplier does not recommend any change to the airbox. However at the risk of the team, the following changes are allowed:

a) The intake ducts, ahead of the air filter, may be changed to suit individual chassis designs.

b) The resonance chambers on top of the airbox lid may be removed, either together with the top cover they are attached to, or the top cover may be left in place. They may be replaced by a blanking cover approximately flat in shape. The total airbox

volume, from the filter back, may not be increased from the original. Refer to Diagram 4 in the Appendix.

If such a blanking cover is fitted, the original air temperature sensor must be fitted on this cover in a position equivalent to the original position, and may not be horizontally closer to the secondary injectors than the original position. Refer to Diagram 5 in the Appendix.

## 2.4 Transmission

2.4.1 A maximum of six gear ratios is permitted.

2.4.2 Twin clutch transmission systems (DSG) are not permitted.

2.4.3 Continuously Variable Transmission systems (CVT) are not permitted.

2.4.4 Automatic transmission systems are not permitted. Manual transmissions with gearshifts assisted by quick-shifter systems are permitted.

## 2.4.5 Moto2 class Clutch

1) A racing slipper clutch (back-torque-limiter) and clutch cover will be supplied to each rider. Only this clutch and cover may be used, without modification, and its use is mandatory at all official Moto2 events.

2) It is the team's responsibility to fit, adjust and maintain all parts of the clutch. Engines returned for maintenance, repair or replacement will have the racing clutch removed, and the team retains their own clutch for use with subsequent engines.

## 2.5 Weights

2.5.1 The following are the minimum weights permitted:

|              |                     |                    |               |
|--------------|---------------------|--------------------|---------------|
| 125cc        |                     | motorcycle + rider | 136 kg        |
| <b>Moto2</b> |                     | <b>motorcycle</b>  | <b>135 kg</b> |
| MotoGP       | 2 cylinders or less | motorcycle         | 135 kg        |
|              | 3 cylinders         | motorcycle         | 142,5 kg      |
|              | 4 cylinders         | motorcycle         | 150 kg        |
|              | 5 cylinders         | motorcycle         | 157,5 kg      |

6 cylinders or more                      motorcycle                      **165 kg**

2.5.2 Ballast may be added to achieve the minimum weights.

2.5.3 Weight may be checked at the initial technical control, but the main control of weight will be made at the end of practice sessions or at the end of the race. The weight of the motorcycle will be that measured in the form that the motorcycle participated, with fuel tank on and including normal levels of oil and water, and all additional equipment attached to the motorcycle, for example timekeeping transponders, camera equipment, electronic datalogging equipment etc.

For the 125cc class the weight checked will be the total of the rider with full protective clothing plus the weight of the motorcycle. Random weight controls may be carried out during practice in a designated weighing area.

## **2.6 Fuel Tanks**

2.6.1 Fuel caps must be leak proof and have a positive closing device.

2.6.2 Fuel tank breather pipes must include a non-return valve. Fuel tank breather pipes must discharge into a suitable container, one per motorcycle with a minimum capacity of 200cc and, for MotoGP only, a maximum capacity of 250cc.

2.6.3 Fuel tanks of all construction types must be filled with fire retardant material or be lined with a fuel cell bladder.

In all classes, fuel tanks made of non-metallic composite materials (carbon fibre, aramid fibre, glass fibre, etc.) must be fitted with a fuel cell bladder, or have passed the appropriate FIM test standards for composite material fuel tanks as described in the FIM Fuel Tank Test Procedure for fuel tank homologation.

Such composite fuel tanks without a fuel cell bladder must bear a label certifying conformity with FIM Fuel Tank Test Standards. Such labels must include the fuel tank manufacturer's name, date of tank manufacture, and name of testing laboratory.

Each manufacturer is requested to inform the FIM/CCR Secretariat of its fuel tank model(s) which have passed the FIM test standards, together with a copy of the fuel tank label.

Full details of the FIM Fuel Tank Test Standards and Procedures are available from the FIM.

Fuel cell bladders must conform to or exceed the specification FIM/FCB-2005. Full details of this standard are available from the FIM.

- 2.6.4 Except for the case that a fuel tank is fixed on the chassis with bolts, all fuel lines from the fuel tank to the engine/carburettor system should have a self sealing breakaway valve. This valve must separate at less than 50% of the load required to break any part of the fuel line or fitting or to pull it out of the fuel tank.  
This rule is mandatory for the MotoGP class.

- 2.6.5 The maximum fuel tank capacity for MotoGP prototype motorcycles is 21 litres.

In defining fuel tank capacity all containers of the motorcycle capable of supplying fuel to the carburettors/injectors may be taken into account.

- 2.6.6 Refuelling may only be carried out from an unpressurised container, and the motorcycle fuel tank may not be artificially pressurised above atmospheric pressure at any time. It is allowed to vent the fuel tank to the atmosphere via the airbox in order to equalise pressure in the airbox and fuel tank.

## 2.7 **Safety and Construction Criteria**

Note: Please also refer to diagrams 1, 2 and 3.

### **Chassis Design and Construction**

**In the Moto2 class, the chassis must be a prototype, the design and construction of which is free within the constraints of the FIM Grand Prix Technical Regulations. The main frame, swingarm, fuel tank, seat and fairing/bodywork from a non-prototype (ie. series production road-homologated) motorcycle may not be used.**

#### 2.7.1 **Throttle Twist grips**

Throttle twistgrips must close automatically when released.

#### 2.7.2 **Steering**

- 2.7.2.1. Handlebars must have a width of not less than 450mm and their ends must be solid or rubber covered. The width of the handlebar is defined as the width measured between the outside of the handlebar grips or throttle twist grips.

2.7.2.2. There must be at least 15 degrees of movement of the steering each side of the centre line.

2.7.2.3. Stops must be fitted to ensure a clearance of at least 30mm between the handlebar and the fuel tank frame and/or bodywork when at the extremes of steering lock.

### **2.7.3 Brakes**

2.7.3.1 Motorcycles must have a minimum of one brake on each wheel that is independently operated.

2.7.3.2 In the 125cc and **Moto2** classes, only brake discs of ferrous materials are allowed.

2.7.3.3 **In the MotoGP class, carbon brake discs may be a maximum diameter of 320mm. From 1.1.2011 onwards carbon brake discs will be allowed with only 320mm diameter, and only 2 standard choices of disc mass. Carbon brakes will be permitted in MotoGP at least until the end of the 2012 season.**

2.7.3.4 **In all classes, ceramic composite materials are not permitted for brake discs or brake pads. Ceramic materials are defined as inorganic, non metallic solids (e.g.  $Al_2O_3$ ,  $SiC$ ,  $B_4C$ ,  $Ti_5Si_3$ ,  $SiO_2$ ,  $Si_3N_4$ ).**

### **2.7.4 Exhausts**

2.7.4.1 The outlet of the exhaust must not extend behind a line drawn vertically through the edge of the rear tyre.

2.7.4.2 For safety reasons the exposed edge of the exhaust pipe outlet must be rounded to avoid any sharp edges.

**2.7.4.3 Variable length exhaust systems are not permitted.**

**2.7.4.4 Exhaust Gas Recirculation (EGR) systems are not permitted.**

**2.7.4.5 Moto2 class exhaust:**

**1) The design and construction of the exhaust system is free provided it conforms to the FIM Grand Prix regulations, and respects the engine Supplier's specified layout (ie. 4 into 2 into 1). There are recommended dimensions from the engine Supplier. Refer to Diagram 6 in the Appendix.**

**2) The Linear Air-Fuel sensor (LAF, or Lambda) will be located 120mm after the final 2 into 1 junction of the exhaust, with a**

**tolerance of 20mm (minimum 100mm, maximum 140mm after the 2 into 1 junction). Refer to Diagram 6 in the Appendix.**

### **2.7.5 Footrests**

2.7.5.1 Footrests must have rounded ends with a minimum solid spherical radius of 8mm.

### **2.7.6 Handlebar Levers**

2.7.6.1 Levers must not be longer than 200mm measured from the pivot point.

### **2.7.7 Bodywork**

2.7.7.1 The windscreen edge and the edges of all other exposed parts of the streamlining must be rounded.

2.7.7.2 The maximum width of bodywork must not exceed 600mm. The width of the seat or anything to its rear shall not be more than 450mm (exhaust pipes excepted).

2.7.7.3 Bodywork must not extend beyond a line drawn vertically at the leading edge of the front tyre and a line drawn vertically at the rearward edge of the rear tyre. The suspension should be fully extended when the measurement is taken.

2.7.7.4 When viewed from the side, it must be possible to see:

- a. At least 180 degrees of the rear wheel rim.
- b. The whole of the front rim, other than the part obscured by the mudguard, forks or removable air-intake.
- c. The rider, seated in a normal position with the exception of the forearms.

Note : No transparent material may be used to circumvent the above rules.

2.7.7.5 No part of the motorcycle may be behind a line drawn vertically at the edge of the rear tyre.

2.7.7.6 The seat unit shall have a maximum height of the (approximately) vertical section behind the rider's seating position of 150mm. The measurement will be taken at a 90° angle to the upper surface of the flat base at the rider's seating position, excluding any seat pad or

covering. Any on-board camera/antenna mounted on the seat unit is not included in this measurement.

2.7.7.7 Mudguards are not compulsory. When fitted, front mudguards must not extend:

- a. In front of a line drawn upwards and forwards at 45 degrees from a horizontal line through the front wheel spindle.
- b. Below a line drawn horizontally and to the rear of the front wheel spindle.

The mudguard mounts/brackets and fork-leg covers, close to the suspension leg and wheel spindle, and brake disc covers are not considered part of the mudguard.

2.7.7.8. Wings may be fitted provided they are an integral part of the fairing or seat and do not exceed the width of the fairing or seat or the height of the handlebars. Any sharp edges must be rounded. Moving aerodynamic devices are prohibited.

2.7.7.9 On motorcycles with four stroke engines, the lower fairing has to be constructed to hold, in case of an engine breakdown, at least half of the total oil and engine coolant capacity used in the engine (min. 5 litres).

The lower fairing should incorporate a maximum of two holes of 25mm. These holes must remain closed in dry conditions and must be only opened in wet race conditions, as declared by the Race Director.

## **2.7.8 Clearances**

2.7.8.1. The motorcycle, unloaded, must be capable of being leaned at an angle of 50 degrees from the vertical without touching the ground, other than with the tyre.

2.7.8.2. There must be a clearance of at least 15mm around the circumference of the tyre at all positions of the motorcycle suspension and all positions of the rear wheel adjustment.

## **2.7.9 Breather Pipes**

Any breather pipe from the engine or gearbox must discharge into **the airbox and/or** a suitable container.

## **2.7.10 Materials**

The use of titanium in the construction of the frame, the front forks, the handle-bars, the swinging arm spindles, and the wheel spindles is forbidden. For wheel spindles, the use of light alloys is also forbidden. The basic structure of the crankshaft and camshafts must be made from steel or cast iron. Pistons, cylinder heads and cylinder blocks may not be composite structures which use carbon or aramid fibre reinforcing materials.

Brake **calipers** must be made from aluminium materials with a modulus of elasticity no greater than 80 Gpa.

No parts of the motorcycle or engine may be made from metallic materials which have a specific modulus of elasticity greater than 50 Gpa / (g/cm<sup>3</sup>).

**The use of MMC (Metal Matrix Composite) and FRM (Fibre Reinforced Metal) materials is forbidden.**

**In the MotoGP class, hollow structure connecting rods are not permitted. Oil galleries of less than 2mm diameter in the connecting rod are permitted.**

#### **2.7.11 Chain Guards**

A guard must be fitted in such a way as to prevent trapping between the lower drive chain run and the final drive sprocket at the rear wheel.

#### **2.7.12 Suspension and Dampers**

**Electric/electronic controlled suspension, ride height and steering damper systems are not allowed. Adjustments to the suspension and steering damper systems may only be made by manual human inputs and mechanical/hydraulic adjusters.**

#### **2.7.13 Tyre temperature sensors are not permitted.**

**Tyre pressure sensors are not permitted in MotoGP only.**

#### **2.7.14 In the Moto2 class, lateral engine covers containing oil and which could be in contact with the ground during a crash, must be protected by a second cover made from composite materials, e.g. type carbon or Kevlar®. Plates and/or bars from aluminium or steel are also permitted. All these devices must be designed to be resistant against sudden shocks and abrasion and must be fixed properly and securely.**

#### **2.8 Wheel Rims**

**2.8.1 Permitted wheel rim sizes** are as follows:

|              | <u>Front</u>                                     | <u>Rear</u>                                       |
|--------------|--|---|
| 125cc        | 2.5" maximum width                               | 3.5" maximum width                                |
| <b>Moto2</b> | <b>3.75" x 17" only</b>                          | <b>6.00" x 17" only</b>                           |
| MotoGP       | 4.0" maximum width<br><b>16.5" diameter only</b> | 6.25" maximum width<br><b>16.5" diameter only</b> |

In the **MotoGP** class for the seasons 2010, 2011, 2012, each manufacturer is restricted to two different widths of front wheel rim, and one width of rear wheel rim, within the maximum widths noted above. All **MotoGP** wheel rims must be 16.5" diameter. Each **MotoGP** manufacturer must notify the Technical Director of their selected wheel sizes no later than the close of technical control at the first race of the 2010 season.

**2.8.2** In the **Moto2** class, composite construction wheels (including carbon fibre reinforced, glass fibre reinforced, and similar) are not permitted.

**2.9 Tyre restrictions**

**2.9.1** In the **MotoGP** and **Moto2** classes, only tyres from the official appointed tyre supplier **for each class** may be used in a Grand Prix event, including official tests.

The official tyre supplier will provide sufficient tyres for all riders entered in the event.

The tyre specifications available at each event will be determined by the tyre supplier. Identical tyres of each specification must be available to every rider, and the **total** quantity of tyres will be the same for every rider.

**2.9.2** On the day prior to the start of official practice, the tyre supplier must provide to the Technical Director details including specifications, quantities and the identification markings of the tyres available for that event.

The Technical Director and staff will allocate the tyres available for the exclusive use of each entered rider (as described in Article 2.9.3). The allocation of individual tyres will be made on a random basis with no involvement of any representative from the tyre supplier, teams or riders.

This allocation should be completed by **14.00** hrs of the same day and no further allocation of tyres is allowed after 17.00 hrs. on the day prior to the start of official practice (except under Arts. **2.9.3 front tyre specification choice**, 2.9.7 or 2.9.8).

In the case of a rider change after the **final** tyre allocation has been made, the replacement rider must use only the tyres allocated to the original rider.

2.9.3 For Grand Prix race events, each rider will be restricted in the quantity and specification of tyres that they may use at a single race event as follows:

**MotoGP Class:**

During all practice sessions, warm up and the race a maximum of **18** slick tyres, specifically:

Front slick tyres:

8 in total, **comprised of either:**

**3 of specification "A" + 5 of specification "B", or:**

**4 of specification "A" + 4 of specification "B", or:**

**5 of specification "A" + 3 of specification "B".**

**Front tyre specification choice will be made as follows:**

**6 tyres comprised of: 3 of specification "A" and 3 of specification "B" will be allocated on the day before the start of official practice, as per Art. 2.9.2.**

**2 tyres will be allocated after the first practice, comprised of:**

**2 of specification "A" or**

**2 of specification "B" or**

**1 each of specification "A" and "B".**

**The rider's selection of front tyre specification must be informed to the tyre supplier no later than 2 hours after the end of the first practice session. If no specification selection is received by this time the allocation of the 2 tyres will automatically be 1 of specification "A" and 1 of specification "B".**

**This allocation will be final and no changes are permitted after this time. In the case of a rider being replaced after this tyre selection deadline, the replacement rider must use only the tyres allocated to the original rider.**

**Rear slick tyres: 5 of Specification "A" + 5 of Specification "B" = 10 in total, all allocated on the day before official practice starts as per Art. 2.9.2**

During all practice sessions, warm up and the race a maximum of 8 wet tyres, specifically

Front wet tyres: 4 of the standard specification

Rear wet tyres: 4 of the standard specification

**Moto2 Class:**

**During all practice sessions, warm up and the race a maximum of 16 slick tyres, specifically:**

**Front slick tyres: 7 in total, comprised of either:  
3 of specification "A" + 4 of specification "B" or  
4 of specification "A" + 3 of specification "B"**

**Front tyre specification choice will be made as follows:  
6 tyres comprised of 3 of specification "A" + 3 of specification "B" will be allocated on the day before the start of official practice as per Art. 2.9.2**

**1 tyre will be allocated after the first practice, comprised of:  
1 of specification "A" or  
1 of specification "B"**

**The rider's selection of front tyre specification must be informed to the tyre supplier no later than 2 hours after the end of the first practice session. If no specification selection is received by this time the allocation of the 1 tyre will automatically be 1 of specification "A".**

**Rear slick tyres: 5 of specification "A" + 4 of specification "B" = 9 in total.**

**During all practice sessions, warm up and the race a maximum of 6 wet tyres, specifically:**

**Front wet tyres: 3 of the standard specification.**

**Rear wet tyres: 3 of the standard specification.**

**Wet tyres, MotoGP and Moto2 classes:**

The tyre supplier may allocate 1 extra set (1 front + 1 rear) of wet tyres to every rider, should this be deemed necessary by Race Direction due to weather conditions at the event. Specifically in the case of every practice session being **declared** wet, **and** requiring the use of wet tyres, 1 extra set of wet tyres will be allocated to every rider for the race.

A wet tyre is defined as a tyre which has a land to sea ratio of at least 20% overall, and a minimum ratio of 7% in each third of the section profile.

The tyre may be moulded or hand cut, but each groove must have a minimum depth of three millimetres over 90% of its length. Any tyre with a land to sea ratio of less than 20% will be deemed a slick tyre and therefore must be part of the rider's slick tyre allocation. In case of dispute the decision of the Technical Director will be final.

- 2.9.4
- 1) Riders may use only the tyres allocated for his/her exclusive use (as described in Article 2.9.3).
  - 2) Tyres will be individually identified and may not be exchanged between riders, including between team-mates, and may not be exchanged by the tyre supplier after allocation, except with the permission of the Technical Director (for example, under Article 2.9.8).
  - 3) Tyres may not be materially altered in any way after allocation, such as hand-cutting and any other action or treatment that will alter the tyre's performance (with the exception of the use of tyre warmers), unless deemed necessary by the tyre supplier. Such alterations may be performed only by the tyre supplier, and shall be made equally for all riders.
- 2.9.5
- Each allocated tyre must be marked with its specification and carry an official identification label with a unique serial number. In the event of damage to or loss of the official label, the tyre company must be able to satisfy the Technical Director as to the tyre's specification. Tyres may be checked for compliance at any time, before or after use.
- 2.9.6
- In the case of an interrupted race, a rider must use tyres from his allocation of marked tyres for the restarted race.
- 2.9.7
- In the unlikely event of a tyre being accidentally damaged before it is used (for example during the fitting process) and deemed to be unusable by the Technical Director, it may be replaced with a tyre of the same specification with the permission of the Technical Director. Such replacement tyres will be marked and included in the allocation of the rider concerned. The damaged tyre will be removed from the allocation and may not be allocated again.

**Once it is used (ie. has exited pit lane) a tyre may not be replaced because of damage or defect, except in the following circumstances:**

- a) The tyre supplier must confirm to the Technical Director that the damage is solely due to a manufacturing defect or problem,**

and not due to any other reason such as impact, cut, abrasion or accident.

b) The tyre supplier must confirm to the Technical Director that the damage is significant enough to deem the tyre unsafe to use.

c) For each rider at any one event, any single tyre deemed to be defective after use will not be eligible for a replacement tyre. Only the second and any subsequent used tyre(s) deemed to be defective by the tyre company (whether due to the same defect or a different defect) during the same event, will be eligible for replacement.

d) In determining whether a replacement will be allowed the decision of the Technical Director will be final.

e) If a replacement tyre is granted, it must be of the same specification as the damaged tyre and selected at random by the Technical Director and/or his staff.

2.9.8 Should an exceptional and unpredictable safety problem arise for the tyre supplier during an event, so as to prevent riders from safely competing in the race, then the tyre supplier must inform the Technical Director and Race Direction of the problem as soon as possible.

A re-allocation of suitable tyres may be made under the supervision of the Technical Director. Such allocated tyres will be the same specification(s) and quantities for all riders, the quantity being determined by the tyre supplier in consultation with the Technical Director.

2.9.9 **Tests, MotoGP Class:**

1) For official Post-Race tests of 1 day duration, each rider will be restricted in the quantity and specification of tyres that they may use at a single test event as follows:

During all practice sessions, a maximum of 8 slick tyres, specifically:

Front slick tyres: 2 of Specification "A" + 2 of Specification "B" = 4 in total.

Rear slick tyres: 2 of Specification "A" + 2 of Specification "B" = 4 in total.

During all practice sessions, a maximum of 4 wet tyres, specifically:

Front wet tyres: 2 of the standard specification

Rear wet tyres: 2 of the standard specification

**In addition each rider may use 1 set of tyres (1 front + 1 rear) retained from their allocation for the preceding event. These tyres may be new or used (NB. used tyres must still be mounted on wheels from the preceding event), and the team must inform the tyre supplier which set of tyres (1 front + 1 rear), if any, they**

**wish to retain for the test within 2 hours of the preceding race finish.**

2) For official Winter tests of 2 days (or more) duration, each rider will be restricted in the quantity and specification of tyres that they may use at a single test event as follows:

During all practice sessions on Day 1, a maximum of 8 slick tyres, specifically:

Front slick tyres: 2 of Specification "A" + 2 of Specification "B" = 4 in total

Rear slick tyres: 2 of Specification "A" + 2 of Specification "B" = 4 in total

During all practice sessions on each additional day, a maximum of 6 slick tyres, specifically:

Front slick tyres: 3 tyres out of the 2 specifications "A" and "B" = 3 in total

Rear slick tyres: 3 tyres out of the 2 specifications "A" and "B" = 3 in total

During all practice sessions over the 2 (or more) days of the test, a maximum of 4 wet tyres per day, up to a maximum total of 8 wet tyres, specifically:

Front wet tyres: 4 of the standard specification, (maximum of 2 per day)

Rear wet tyres: 4 of the standard specification, (maximum of 2 per day)

3) At any official Post-race or Winter test, the tyre supplier may choose to allocate extra tyre sets with a different specification. Such extra allocation will be determined solely by the tyre supplier.

The same quantity of identical specification tyres will be allocated to at least all permanent MotoGP class riders contracted to factory teams at the test.

When a new specification tyre is to be introduced, the tyre supplier should inform all teams at least two months in advance of the proposed test date for the new specification.

#### **Tests, Moto2 Class:**

**For all winter and post-race tests, each rider will be restricted in the quantity and specification of tyres they may use at a single test. The tyre supplier will determine the number of specifications and quantities it will bring to each test. Every rider present will receive the same allocation of standard tyre specifications and quantities.**

**The tyre supplier may choose to provide additional tyres of a different specification, for tyre development purposes. The**

**allocation of any development tyres will be solely at the discretion of the tyre supplier.**

## **2.10 Numbers and Backgrounds**

**2.10.1** Racing number must be affixed to the front and the two sides of the motorcycle. For the **MotoGP and Moto2** classes, only the front number is compulsory.

2.10.2 Numbers **should** be a minimum height of 140 mm.

2.10.3 Numbers must be **easily legible**, distinctive and contrast strongly with the background colour.

2.10.4 Backgrounds must be of one single colour over an area large enough to provide a minimum clear area of 25mm around the numbers.

2.10.5 In case of a dispute concerning the legibility of numbers, the decision of the Technical Director will be final.

## **2.11 Fuel and Oil**

All motorcycles must be fuelled with unleaded petrol.

### **Moto2 class fuel and oil:**

**1) Only fuel from the appointed fuel supplier is permitted. This fuel will be available at all official Moto2 events, and will conform to the FIM Grand Prix specification. Use of this fuel without any addition or alteration is mandatory.**

**2) Only engine oil from the appointed oil supplier is permitted. This oil will be available at all official Moto2 events and will conform to the FIM Grand Prix 'Moto2' specification. The use of this oil without any addition or alteration is mandatory. The Technical Director may require that an oil sample be taken from any team or machine at any time.**

2.11.1 Unleaded petrol must comply with the FIM Grand Prix specification **for each racing class.**

2.11.2 Unleaded petrol will comply with the FIM Grand Prix specification if:

(a) It has the following characteristics:

| Property            | Units             | Min.             | Max.  | Test Method                         |
|---------------------|-------------------|------------------|-------|-------------------------------------|
| RON                 |                   | 95.0             | 102.0 | ISO 5164                            |
| MON                 |                   | 85.0             | 90.0  | ISO 5163                            |
| Oxygen              | % m/m             |                  | 2.7   | ASTM 4815                           |
| Benzene             | % v/v             |                  | 1.0   | EN 238                              |
| RVP                 | kPa               |                  | 90    | EN 13016-1                          |
| Lead                | g/l               |                  | 0.005 | EN 237                              |
| Density at 15 °C    | kg/m <sup>3</sup> | 720.0            | 775.0 | ASTM D 4052                         |
| Oxidation Stability | minutes           | 360              |       | ASTM D 525                          |
| Existent gum        | mg/100 ml         |                  | 5.0   | EN ISO 6246                         |
| Sulphur             | mg/kg             |                  | 10    | ASTM D 5453                         |
| Nitrogen            | % m/m             |                  | 0.2   | ASTM D 4629                         |
| Copper Corrosion    | rating            |                  | C1    | ISO 2160                            |
| Distillation:       |                   |                  |       |                                     |
| At 70 °C            | % v/v             | 22.0             | 50.0  | ISO 3405                            |
| At 100 °C           | % v/v             | 46.0             | 71.0  | ISO 3405                            |
| At 150 °C           | % v/v             | 75.0             |       | ISO 3405                            |
| Final Boiling Point | °C                |                  | 210.0 | ISO 3405                            |
| Residue             | % v/v             |                  | 2.0   | ISO 3405                            |
| Olefins(*)          | % v/v             |                  | 18.0  | ASTM D 1319:1998 Gas Chromatography |
| Aromatics(*)        | % v/v             |                  | 35.0  | ASTM D 1319:1998 Gas Chromatography |
| Total di-olefins    | % m/m             |                  | 1.0   | GCMS / HPLC                         |
| Appearance          |                   | clear and bright |       | visual inspection                   |

The measurement error in each test method is included in the min./ max. values given in the table and will not be added following the analysis. In case of a dispute, the test method will be Gas Chromatography (\*).

(b) The total of individual hydrocarbon components, containing only hydrogen and carbon, present at concentrations of less than 5% m/m must be at least 30% m/m of the fuel.

Compliance with the compositional regulation is calculated on the following basis:

$$A = 100 - B - C$$

where:

A is the total concentration (in % m/m) of individual hydrocarbon components present at concentrations less than 5 % m/m,

B is the total concentration (in % m/m) of oxygenates present in the fuel, and

C is the total concentration (in % m/m) of individual hydrocarbon components present at concentrations greater than 5% m/m.

The test method will be gas chromatography.

(c) The total concentration of naphthenes, olefins and aromatics in each carbon number group will not exceed the limits given in the following table.

| % m/m      | C4 | C5 | C6  | C7 | C8 | C9+ |
|------------|----|----|-----|----|----|-----|
| Naphthenes | 0  | 5  | 10  | 10 | 10 | 10  |
| Olefins    | 5  | 20 | 20  | 15 | 10 | 10  |
| Aromatics  |    |    | 1.2 | 35 | 35 | 30  |

Bicyclic and polycyclic olefins are not permitted. The fuel must contain no substances which are capable of exothermic reaction in the absence of external oxygen.

(d) Only the following oxygenates will be permitted:

Methanol, Ethanol, Iso-propyl alcohol, Iso-butyl alcohol, Methyl tertiary butyl ether, Ethyl tertiary butyl ether, Tertiary amyl methyl ether, Di-isopropyl ether, n-Propyl alcohol, Tertiary butyl alcohol, n-Butyl alcohol, Secondary butyl alcohol.

(e) Manganese (<1 mg/L), lead (<5 mg/L), iron (<5 mg/L) and nickel (<5 mg/L) additives are not permitted above these limits.

(f) Oil for two stoke mixtures will comply with the FIM Grand Prix specifications if:

| Test              | Limits |      | Test Method       |
|-------------------|--------|------|-------------------|
|                   | low    | high |                   |
| Metals            |        |      | ICP-OES<br>GC-AED |
| Lead (mg/kg)      |        | 10   |                   |
| Manganese (mg/kg) |        | 10   |                   |
| Iron (mg/kg)      |        | 10   |                   |

|   |  |    |                        |
|---|--|----|------------------------|
| Nickel (mg/kg)                          |  | 10 |                        |
| Percentage boiling under 250°C (g/100g) |  | 10 | Simulated Distillation |

4 volumes of oil will be added to 100 volumes super unleaded and the following tests will be carried out on the mixture.

|   | Limits |      | Test Method |
|---|--------|------|-------------|
|   | low    | high |             |
| Research Octane Number (RON):<br>difference in research octane number between petrol with and without oil | -2     | +1   | ISO 5164    |
| Motor Octane Number (MON):<br>Difference in motor octane number between petrol with and without oil       | -2     | +1   | ISO 5163    |
| Density at 15°C (kg/m <sup>3</sup> )<br>difference in density between petrol with and without oil         |        | +30  | ASTM D 4052 |

The distillation behaviour of the oil will be used to identify it after the race.

The oil may not alter the fingerprint of the petrol.

(g) For 2-stroke mixtures the following tolerances on the petrol specifications will be allowed:

|                        |                           |
|------------------------|---------------------------|
| • Density at 15 °C     | plus 30 kg/m <sup>3</sup> |
| • Distillation residue | not controlled            |

**(h) In the Moto2 class, oil for engine lubrication will comply with the FIM Grand Prix Moto2 specification if it matches the reference GC fingerprint established by the appointed oil supplier.**

**(i) In the Moto2 class, the fuel and oil specification will be determined by the appointed fuel supplier and oil supplier in consultation with the Organisers and the official engine supplier and may be changed at any time by mutual agreement.**

### 2.11.3 Implementation of the fuel regulation

**In the MotoGP and 125cc classes** when a rider taking part in a meeting is under contract or agreement for the exclusive use of a certain brand of petrol or oil, the Organisers must give free access to the circuit for that fuel or oil.

Any final dispute will be settled in accordance with the FIM Grand Prix Disciplinary and Arbitration Code.

## **2.11.4 Fuel Analysis Procedure**

### **2.11.4.1 Fuel and Oil Approval**

1. All fuel in use in the Championship must be approved prior to the race in which the fuel is to be used. Fuel companies supplying petrol to participating teams must submit ten litres (2 x 5 L) to the laboratory appointed by the FIM/Dorna for analysis in accordance with the specification. Providing the petrol is within the specification, a certificate containing a test report number will be issued. The test report number must be given to the appropriate teams before they take part in a race.

2. All companies supplying oil, for mixing with petrol to create a two stroke mixture **or for engine lubrication in the Moto2 class**, to participating teams must submit two litres (2 x 1 L) of the oil to the laboratory appointed by the FIM/Dorna for approval. If the oil conforms to the specifications, a certificate will be issued. The test report number given on the certificate must be supplied to teams which intend to use the oil.

3. During Thursday's technical control, each team will declare the certificate test report numbers corresponding to the petrol and oil to be used. This information will be entered in the Technical Control Book of each motorcycle at every Grand Prix.

Therefore, the fuel which is to be used must be approved by the Thursday afternoon before the race in which the fuel is to be used.

4. When a fuel sample is requested at any Grand Prix Circuit, either during practice, warm up or following the race, the certificate test report numbers corresponding to the petrol and oil used must be declared to the Grand Prix Technical Director by the team. Failure to provide the correct number will result in a fine.

5. Each fuel and/or oil Company will be responsible for payment to the laboratory for these batch analyses costs and establishment of the basic fingerprints.

#### **2.11.4.2 Fuel and Oil Sampling and Testing**

1. The Grand Prix Technical Director will appoint a senior Technical Scrutineer to take responsibility for the administration and supervision of the fuel sampling procedure.

2. Motorcycles selected for fuel controls will usually be amongst the first three finishers, and will be directed to the "parc fermé" for technical controls.

3. Other finishers may be chosen at random for fuel controls. A Technical Scrutineer will be posted at the entrance to the pit box of the selected rider(s) whose machine must immediately accompany the Technical Scrutineer to the technical control area or "parc fermé".

4. The fuel to be tested will be transferred into two bottles, "A" and "B" identified by reference to the rider, team and machine from which the sample was taken. The bottles will be closed, sealed and labelled by the Technical Director and/or Technical Scrutineer.

5. Only new bottles will be used for the fuel samples and only new materials will be used to transfer the fuel.

6. The Fuel Sample Declaration form will be filled out immediately, containing all information as shown in the example sheet, including the riders and machines identity, date and place of fuel sampling. A responsible team member will sign this declaration, after verifying that all the information is correct.

7. Sample "A" will be sent to the official appointed laboratory, accompanied by a copy of the Fuel Sample Declaration form. The fuel sample will be compared with the approved petrol and oil using gas chromatography. If necessary the concentration of other elements, including lead, manganese, iron, nickel, nitrogen and oxygen may be measured at the request of the Technical Director to ensure that octane and power boosters have not been added.

If any observed deviations of the GC curve indicate that they are due to mixing with one other fuel, which has been approved by the FIM/Dorna for use by the team, the fuel sample will be deemed to comply, provided the fuel sample still falls within FIM Grand Prix specification as described in Article 2.11.2.

Costs for the analyses of sample "A" will be paid by FIM/Dorna.

8. Sample "B" will be handed over to the FIM designated storage facility for safeguarding in case of protests and/or requirement of a counter analysis by the appointed laboratory. Costs for the analyses of sample "B" will be paid by the team concerned.

9. Both samples will be transported by an authorised courier.

10. The laboratory must deliver the results of the fuel sample analyses to the Grand Prix Technical Director, with a copy to the FIM, as soon as possible after receipt of the samples, and before the Friday evening of the following Grand Prix event.

11. In the case of non-conformity, the Technical Director must notify, as soon as practical after receipt of the results, the FIM, the Grand Prix Race Direction and the rider/team representative concerned.

Within 48 hours of the receipt of the notification of the results of the laboratory test of sample "A", the team must notify the FIM and the Technical Director if counter-expertise is required (or not required) for sample "B".

The Race Direction will take a decision at the Grand Prix event immediately following the notification of the results of the final expertise. Any appeal against the decision of the Race Direction will be heard by the FIM Stewards appointed for the Grand Prix event at which the Race Direction decision is taken.

If there is no more Grand Prix following the notification of the results of the final expertise, the Race Direction will take a decision as soon as practical. Any appeal against the decision of the Race Direction will be heard by the FIM Stewards appointed by the FIM for this specific task.

12. The director of fuel analysis at the official laboratory must confirm to the Technical Director that the identification and the seal status of the "B" sample is correct before any B sample analysis is carried out.

13. Failure of the sample to comply to approved petrol and oil, and/or the addition of octane and power boosters, as described in article 2.11.4.2.7, will automatically result in the disqualification of the competitor from the entire meeting.

The result of the competitor's fuel sample analysis ("A" or "B" sample) more favourable to the competitor will be taken into account.

**14. In the Moto2 class, the above fuel sampling and testing procedure will apply to engine oil also. In the case that the oil sample does not comply with the Moto2 specification as described in Art. 2.11.2.(h), the Technical Director will inform Race Direction who may impose a penalty.**

2.11.5 For the MotoGP race, no fuel on the motorcycle may be more than fifteen degrees C (15°C) below ambient temperature. The use of any device on the motorcycle to artificially decrease the temperature of the fuel below ambient temperature is forbidden.

For the purposes of this regulation an Official Ambient Temperature will be declared and displayed on the timekeeping monitors one hour before the start of the MotoGP race. The team must comply with requests of the Technical Director and Technical Scrutineers checking pre-race fuel temperature, including opening the fuel tank cap if necessary. Fuel on the motorcycle must comply with the temperature regulation no later than 5 minutes before pit lane opens.

## **2.12 Protective Clothing and Helmets**

2.12.1 Riders must wear a complete leather suit with additional leather padding or other protection on the principal contact points, knees, elbows, shoulders, hips etc.

2.12.2 Linings or undergarments must not be made of a synthetic material which might melt and cause damage to the riders' skin.

2.12.3 Riders must also wear leather gloves and boots, which with the suit provides complete coverage from the neck down.

2.12.4 Leather substitute materials may be used, providing they have been checked by the Chief Technical Scrutineer.

2.12.5 Use of a back protector is highly recommended.

2.12.6 Riders must wear a helmet which is in good condition, provides a good fit and is properly fastened.

2.12.7 Helmets must be of the full face type and conform to one of the recognised international standards:

- Europe ECE 22-05 'P'
- Japan JIS T 8133 : 2000, **JIS T 8133: 2007**
- USA SNELL M 2005, **SNELL M 2010**

- 2.12.8 Visors must be made of a shatterproof material.
- 2.12.9 Disposable "tear-offs" are permitted.
- 2.12.10 Any question concerning the suitability or condition of the riders clothing and/or helmet shall be decided by the Technical Director, who may, if he so wishes, consult with the manufacturers of the product before making a final decision.

## **2.13 Procedures for Technical Control**

- 2.13.1 At each circuit an area must be designated as the Technical Checking Area. In this area, under the control of the Chief Technical Scrutineer and the supervision of the Technical Director, suitable equipment will be installed to conduct the various tests viz:
- i ) Equipment for measuring the noise of the motorcycle.
  - ii ) Weighing scales with check weights for calibration purposes.
  - iii ) Instruments for measuring engine capacity.
  - iv) Instruments and gauges as necessary for measuring other dimensions and criteria specified in the Technical Regulations.
- 2.13.2 The technical control procedure will be carried out in accordance with the schedule set out in the Regulations. The technical scrutineers must be available throughout the event to check motorcycles and equipment as required by the Technical Director.
- 2.13.3 Presentation of a machine will be deemed as an implicit statement of conformity with the technical regulations. Responsibility for the preparation of the machine to comply with all technical and safety regulations rests with the team.
- 2.13.4 A rider's presence at the initial technical control is not mandatory, except in the case of the 125cc class when the rider must be present for a weight check together with his helmet and all protective clothing.
- 2.13.5 Motorcycles will be inspected under the name of the team and at the initial technical control each motorcycle will be registered by the technical scrutineers who will prepare a technical control card to record technical specifications, check results and the riders in that team entitled to use the motorcycle.

- 2.13.6 At the initial technical control the technical scrutineers should inspect the motorcycle to record technical details including weight (plus rider weight in the 125cc class), noise level and may also check the motorcycle for technical compliance with other aspects of the Regulations, as requested by the Technical Director.
- 2.13.7 All machines must have a correctly-positioned timekeeping transponder. The transponder must be supplied or approved by the official Timekeeper and fixed to the motorcycle in the position and orientation as shown in the timekeeping information given to teams pre-season and available at each Grand Prix. Correct attachment of the transponder bracket consists of a minimum of tie-wraps, but preferably by screw or rivet. Velcro or adhesive alone will not be accepted, and any transponder retaining clip must also be secured by a tie-wrap.
- 2.13.8 At each event, at the conclusion of technical control procedures prior to the first practice, the technical scrutineers will place a small sticker on the motorcycle indicating that it has been registered for use by the team's rider(s) for that race and passed the technical control procedures.
- 2.13.9 The Chief Technical Scrutineer will prepare a report on the results of technical control which, will be submitted to the Event Management Committee via the Technical Director.
- 2.13.10 The technical scrutineers should re-inspect any machine that has been involved in an accident, and if necessary to issue a new technical control sticker for a rebuilt machine. This would normally be carried out at the pit of the rider concerned. The team has sole responsibility for any repairs carried out, and to determine when the machine is fit for further use.
- 2.13.11 The technical scrutineers must be available, based on instructions from the Technical Director, to re-inspect any motorcycle for technical compliance during the meeting or after the race and to supervise inspection of a motorcycle following a protest on a technical matter.
- 2.13.12 At the end of the race, the Chief Technical Scrutineer will ensure that the motorcycles placed in the first three positions, plus any other motorcycles designated by the Technical Director, are placed in the Check Area for a period of 60 minutes pending any protest.

The motorcycles should be checked for compliance with the noise and weight regulations, and any other technical requirement, under the control of and as requested by the Technical Director

2.13.13 The Technical Director may require a team to provide such parts or samples as he may deem necessary.

## 2.14 Noise Tests

2.14.1 Noise tests must be conducted in an open area with a space of at least 10 metres between the motorcycle being tested and walls or other obstacles. There should be a minimum amount of ambient noise in the area.

2.14.2 The measuring equipment must be calibrated prior to the test and recalibrated at regular intervals.

2.14.3 The measuring equipment should be placed 50 cm from the end of the exhaust pipe and at 45 degree angle to the pipe either to the side or above.

2.14.4 The maximum noise levels at all times are:

2 stroke: 113 dB/A  
**Moto2: 115 dB/A**  
**MotoGP 4 stroke: 130 dB/A**

For convenience, made possible by the similarity of piston stroke per engine configuration within capacity classes, the test may be conducted at a fixed RPM.

|                      | 1 cylinder | 2 cylinders | 3 cylinders | 4 cylinders and more |
|----------------------|------------|-------------|-------------|----------------------|
| 125 cc               | 7'000 RPM  |             |             |                      |
| MotoGP, <b>Moto2</b> |            | 5'000 rpm   | 5'500 rpm   | 5'500 rpm            |

**DIAGRAM 1**

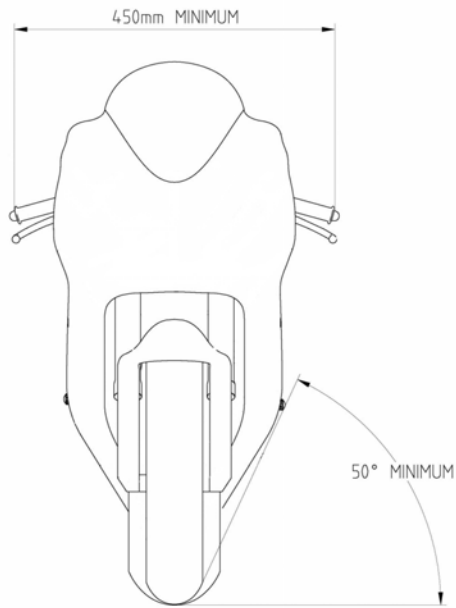

**DIAGRAM 2**

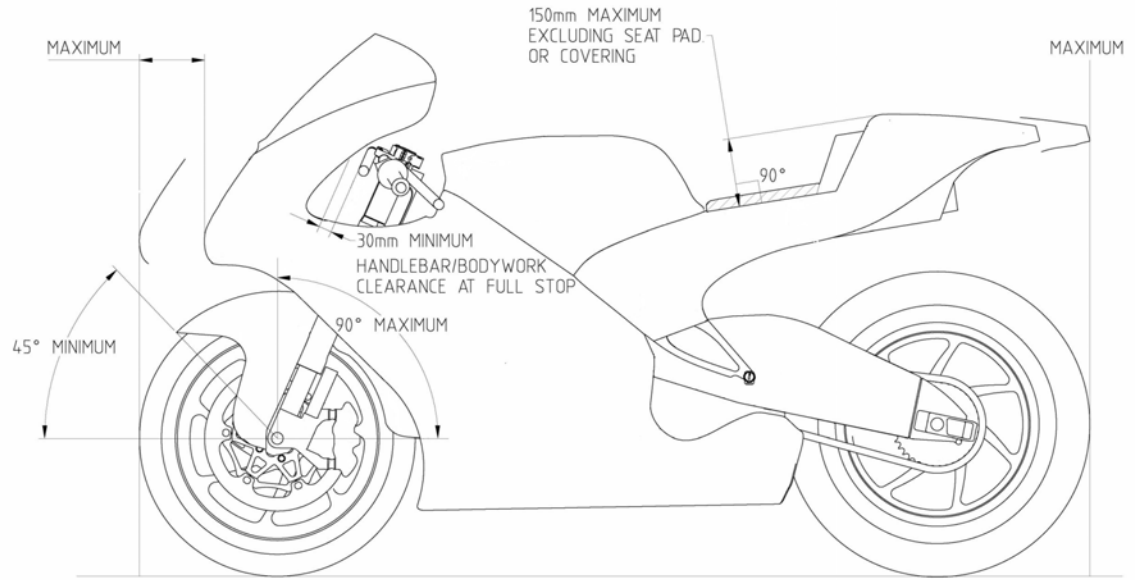

**DIAGRAM 3**

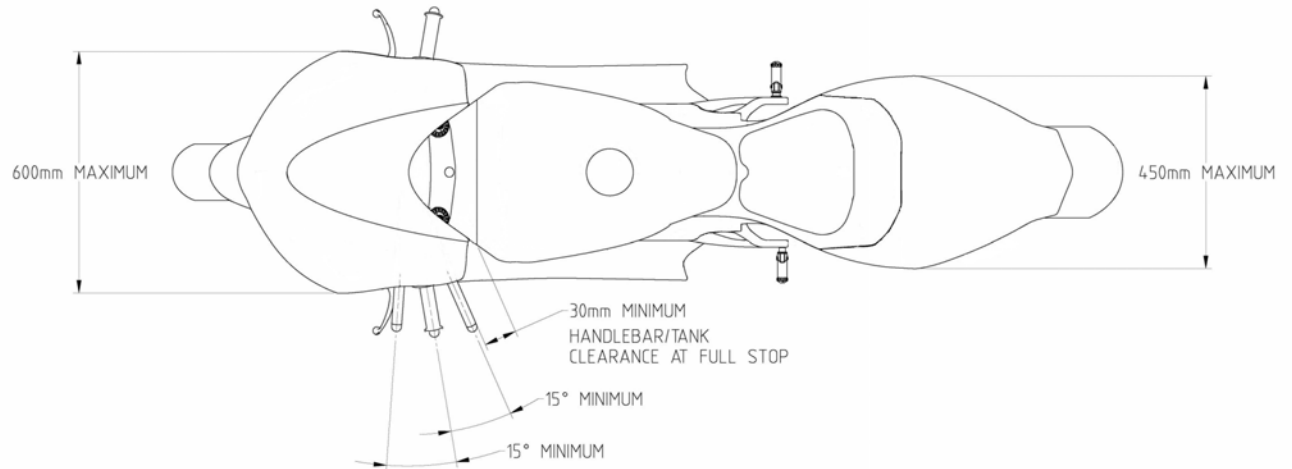

#### Diagram 4: Airbox

The main airbox body, shown inside the line, must be original and is mandatory.

The intake duct (“intake connection to frame”) may be replaced.

The resonance chambers on the airbox lid, including the top cover if required, may be removed and replaced with an approximately flat blanking cover.

Airbox volume, from the filter back, must not be more than the original.

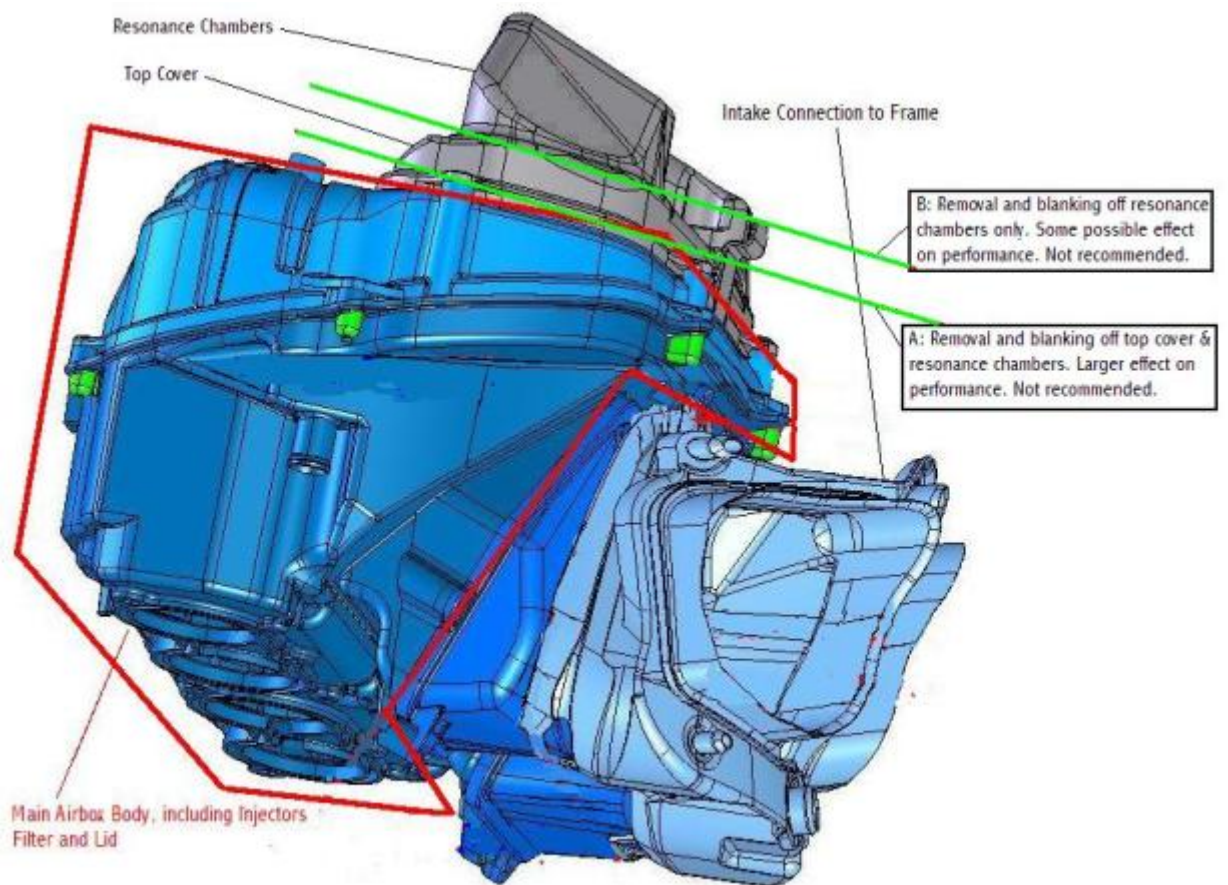

**Diagram 5: Air temperature sensor position**

If a blanking cover is fitted on the airbox lid, the air temperature sensor should be fitted in the position as shown below. It must not come into contact with any other parts in the airbox, and must not be positioned closer (measured horizontally) to the secondary injectors than the standard position on the original cover (that is, it must not be behind the “32mm” line shown below).

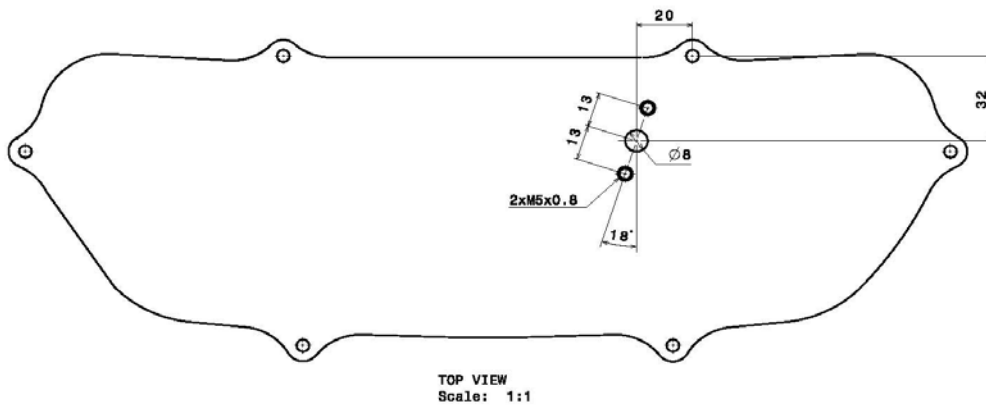

**Diagram 6: Recommended exhaust specification**

**MOTO2 EXH PIPE SPEC**

**EXH PIPE DIMENTION ( WITH OUT MUFFLER )**

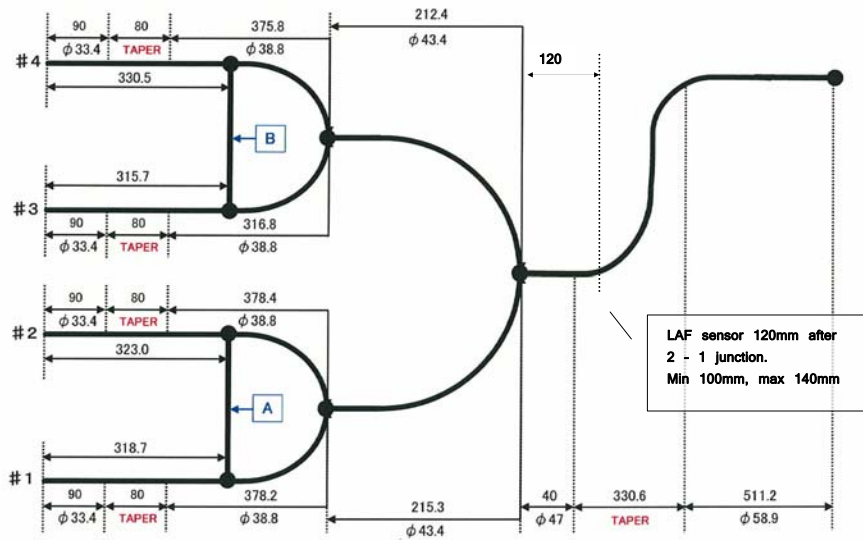

※ A,B Joint pipe -  $\phi 19$  / Hole diameter of connecting part -  $\phi 16$  ( Reference  $t=0.8$  SUS )  
 ※ Pipe diameter - Everything is written by the inside diameter.

**Table 1: Datalogging Sensors permitted at official Moto2 events:**

| <b><u>STANDARD CHANNELS (SUPPLIED AS MOTO2 KIT)</u></b>  | <b><u>SENSOR</u></b>         |
|--|------------------------------|
| Front Wheel Speed  | supplied in kit              |
| Rear Wheel Speed   | calculated from g/box        |
| Front Suspension   | supplied in kit, 150mm       |
| Rear Suspension  | supplied in kit, 75 or 100mm |
| Front Brake Pressure                                     | supplied in kit              |
| Linear A/F (Lambda) Amplifier & ECU Input Module         | supplied in kit              |
| RPM  | from engine                  |
| Throttle Position  | signal from ECU              |
| Water Temperature  | signal from ECU              |
| Manifold Pressure  | signal from ECU              |
| Air Temperature  | signal from ECU              |
| Oil Pressure Switch                                      | signal from ECU              |
| Pitlane Speed Limiter                                    | from ECU, Dashboard          |
| Laptime  | from Transponder             |
| V_GPS  | from 2D Moto2GPS             |
| Bank Angle   | from 2D Moto2GPS             |
| Latitude   | from 2D Moto2GPS             |
| Longitude  | from 2D Moto2GPS             |
| Time   | from 2D Moto2GPS             |
| Vbattery   | internal                     |
| <b><u>OPTIONAL CHANNELS (AVAILABLE FOR PURCHASE)</u></b> |                              |
| Pressure Sensor (Oil/Fuel Pressure)                      | purchase sensor              |
| Rear Brake Pressure                                      | purchase sensor              |
| Front Axle Accelerometer                                 | purchase sensor              |
| Rear Axle Accelerometer                                  | purchase sensor              |
| Gyro   | purchase sensor              |
| Tyre Pressure Sensor                                     | purchase sensors, receiver   |
| Pitch Calculation  | supplied software, no charge |
| Suspension Speed   | supplied software, no charge |
| V_Rear   | supplied software, no charge |

**Table 2: Engine operating parameters:**

|                             |   |
|-----------------------------|---|
| Crankshaft speed            | 16,000 rpm maximum  |
| Operating water temperature | 60 - 80°C   |
| Air/Fuel Ratio target range | 13.5 - 12.8   |
| Oil level                   | Start of practice/race: at maximum level mark<br>At all times between minimum and maximum level marks |
| Oil pressure                | Low oil pressure warning must be respected  |

**TECHNICAL CONTROL  
GRAND PRIX ROAD RACING WORLD CHAMPIONSHIP, MotoGP**

POST-RACE FUEL SAMPLES TAKEN FOR LABORATORY ANALYSIS

Date

FINISHING POSITION :

RACE N°:

RIDER :

MOTORCYCLE MAKE:

TEAM:

LABORATORY TEST REPORT CERTIFICATE N° :

FUEL:

OIL:

SAMPLE BOTTLE LABEL N°:

SAMPLE BOTTLE "A", LABEL N°:

SAMPLE BOTTLE "B", LABEL N°:

AMBIENT TEMPERATURE:            C°

MOTORCYCLE N°:            **1** / **2**  
(circle as applicable)

The above listed details refer to fuel samples taken from the fuel tank of the motorcycle specified after the race whilst in the Check Area for a period of 60 minutes pending any protest.

Sample "A" will go to the appointed laboratory for analysis and comparison with the approved gas chromatogram safeguarded by the approved laboratory.

Sample "B" will be safeguarded by the FIM for counter-analysis (if required).

As a responsible member of the Team named on this sheet, I, \_\_\_\_\_  
have controlled the serial numbers of the Sample Bottle Labels and hereby certify the accuracy of the listed information.

Time: \_\_\_\_\_

Signature: \_\_\_\_\_

Position in Team: OWNER / MANAGER / MECHANIC  
(circle as applicable)

### 3. DISCIPLINARY AND ARBITRATION CODE

#### 3.1 Principles

The obligations incumbent upon the participants, officials and organisers are set out in the Regulations published by the FIM.

Proven violation or non-observance of these obligations will be subject to the penalties laid down in this chapter.

#### 3.2 Penalties

The penalties are:

- warnings
- fines
- ride through
- change of position
- time penalties
- disqualification
- withdrawal of Championship points
- suspension
- exclusion

##### 3.2.1 Definition and application of penalties

- |                                      |   |
|--------------------------------------|---|
| - warnings :                         | can be made privately or publicly.  |
| - fines:                             | cash penalty from <b>500€ up to 50'000€</b>   |
| - ride through                       | see Art. 1.19   |
| - change of position                 | see Art. 1.22.2   |
| - time penalties:                    | the imposition of time affecting the rider's actual result up to 2 minutes and the cancellation of time.  |
| - disqualification:                  | disqualification from an event, practice sessions (black flag, black flag with orange disc), race (black flag, black flag with orange disc) or from its results |
| - withdrawal of Championship points: | the loss of points from the Championship races already run  |
| - suspension:                        | the loss of rights to participate in the Championship may be applied to one or more races.  |

- exclusion: the final and complete loss of all rights of participation in any activity under FIM control.

### **3.2.2 Plurality of penalties**

Any offender may have several penalties pronounced against him according to the circumstances.

### **3.3 The Disciplinary and Arbitration Bodies**

The disciplinary and arbitration bodies of the FIM, qualified to deal with disciplinary and arbitration matters, are:

- The Race Direction
- The FIM Stewards
- The International Disciplinary Court (CDI)

#### **3.3.1 The Race Direction**

##### **3.3.1.1 Constitution**

The Constitution of the Race Direction is in accordance with the requirements laid down in Article 1.6.

##### **3.3.1.2 Authority and Competence**

The Race Direction has the authority to penalise automatically riders, teams' personnel, officials, promoters/organisers and all the persons involved in any capacity whatsoever in an event or in the Championship for :

- Infringements of the Regulations.
- any voluntary or involuntary action or deed accomplished by a person or a group of persons during a meeting, contrary to the current Regulations or instructions given by an official of the meeting.
- any corrupt or fraudulent act, or any action prejudicial to the interests of the meetings or of the sport, carried out by a person or a group of persons occurring during an event.

The Race Direction is competent to adjudicate upon a protest relating to infringements of the Regulations.

### **3.3.1.3 Penalties that may be pronounced by the Race Direction**

The following penalties may be pronounced by the Race Direction:

- a warning
- a fine
- a ride through
- a change of position
- a time penalty
- a disqualification
- a withdrawal of Championship points
- a suspension

Furthermore, the Race Direction can refer the case to the International Disciplinary Court (CDI) in order to impose a higher penalty than the Race Direction is empowered to do.

## **3.3.2 The FIM Stewards Panel**

### **3.3.2.1 Constitution**

The Constitution of the FIM Stewards Panel is in accordance with the requirements laid down in Article 1.7.

### **3.3.2.2 Competence**

The FIM Stewards Panel will hear any appeals against decisions taken by the Race Direction.

### **3.3.2.3 Penalties that may be pronounced by the FIM Stewards Panel only following an appeal :**

- a warning
- a fine
- a time penalty
- a disqualification
- a withdrawal of Championship points
- a suspension

Furthermore, the FIM Steward Panel can refer the case to the International Disciplinary Court (CDI) in order to impose a higher penalty than the FIM Stewards Panel is empowered to do.

### **3.3.3 The International Judicial Panel**

The International Judicial Panel (CJI) is composed of qualified persons from which the members of the CDI are nominated.

#### **3.3.3.1 Constitution**

The International Judicial Panel shall consist of members nominated by FMNs. Each FMN may nominate one or several members having the nationality of that FMN. The appointments shall be confirmed by the General Assembly for 4-year periods.

#### **3.3.3.2 Qualifications**

In order to qualify for appointment to the International Judicial Panel, a candidate must be in possession of a diploma in Law studies of University level. He must be able to express himself in at least one of the official languages of the FIM. He cannot however be an officer or a licence holder of the FIM.

### **3.3.4 The International Disciplinary Court (CDI)**

#### **3.3.4.1 Appointment of the Members**

The President of the International Judicial Panel of the FIM will appoint, each time, the President and the members who will constitute the CDI.

#### **3.3.4.2 Procedures**

The names of the members appointed must be communicated to all interested parties in the case, who have the right to make a duly documented objection to the composition of the Court, either in total or in part, within three days after having received the information. If the Executive Board of the FIM considers that a reasonable objection is made, he must appoint the necessary replacements. Otherwise he rejects the objection and fixes the date for the hearing.

The court may request the opinion of an expert or summon a witness who it considers useful.

### **3.3.4.3 Authority and Competences**

The CDI will hear any appeals against decisions taken by the FIM Stewards.

The CDI adjudicates upon request of the Race Direction or the FIM Steward Panel.

### **3.3.5 The FIM as a Party in the Legal Proceedings**

#### **3.3.5.1 Function**

For all the appeals to the CDI, the FIM is entitled to assert its interests or to explain its position by means of a prosecution address.

#### **3.3.5.2 Appointment**

The Executive Board shall appoint in each case, the person who will represent the FIM.

#### **3.3.5.3 Procedure**

The intervention of the FIM is optional and is left to the appreciation of the Executive Board.

As a party, the FIM enjoys the same rights and obligations as the other parties.

The FIM may be present in person at a hearing or may present its claims in writing.

### **3.4 Protests and Appeals**

#### **3.4.1 Right of protest**

Any legal entity or any individual, rider, team, manufacturer, official etc. affected by a decision taken under the authority of the FIM, has the right to protest against that decision.

No protest may be lodged against a decision of the Race Direction entailing or not:

- a change of position.
- a ride through.

- a disqualification from the practice sessions or races by means of a black flag or black flag with orange disc.
- a fine for speeding in the pit lane.

No protest may be lodged against a decision of the Race Direction based on a photo finish.

### **3.4.2 Right of appeal**

The rules concerning appeals against FIM disciplinary decisions are:

#### **1. To the FIM Stewards against a decision of the Race Direction**

No appeal may be lodged against a decision entailing or not:

- a change of position
- a ride through
- a disqualification from the practice sessions or races by means of a black flag or black flag with orange disc.
- a fine for speeding in the pit lane

No appeal may be lodged against a decision based on a photo finish.

**When no** appeal may be lodged **the** decision of the Race Direction decision is final.

#### **2. To the CDI against a decision of the FIM Stewards. The decision of the CDI is final.**

**No appeal may be lodged if the FIM Stewards confirm the previous decision of the Race Direction. In this case, the decision of the FIM Stewards is final.**

#### **3. To the CAS**

**No appeal may be lodged against a decision entailing or not:**

- **a change of position**
- **a ride through**
- **a disqualification from the practice sessions or races by means of a black flag or black flag with orange disc**
- **a fine for speeding in the pit lane**

**No appeal may be lodged against a decision based on a photo finish.**

### **3.4.3 Procedure and time limit for protests**

All protests must be submitted and signed only by the person directly concerned. Each protest must refer to a single subject only and must be presented within 1 hour at the latest after the publication of the results. Protests must be handed to a responsible official (Clerk of the Course, Race Director or Secretary of the Meeting) together with the security deposit **of 600 €** or equivalent.

Teams and riders contracted to compete in the Championship may submit a letter of guarantee from IRTA in lieu of payment.

A protest against the eligibility of a rider, team or a motorcycle entered, must be made before the start of the official practice.

### **3.4.4 Hearing of a protest**

After a hearing, the Race Direction must make a decision on any protest presented. The protest has to be judged according to the provisions of the Regulations.

### **3.4.5 Effect of the decision upon a protest**

The decision of the Race Direction of determination of penalty is immediate.

### **3.4.6 Time limits for the lodging of an appeal**

The time limit for lodging a statement of appeal is:

|  |              |
|--|--------------|
| against a decision of the Race Direction                             | - 30 Minutes |
| against a decision of the FIM Stewards                               | - 5 days     |
| statement of appeal before the Court of Arbitration for Sports (CAS) | - 5 days     |

The time limits shall be taken from the date and time of receipt of the decision by the appellant.

### **3.4.7 Lodging of an appeal**

To be admissible, the statement of appeal must be submitted by letter (appeal before the FIM Stewards) or sent by registered letter or

special courier to the FIM Executive Secretariat and postmarked (appeal before the CDI).

The correct security deposit for appeal must be handed to the FIM Chief Steward (appeal before the FIM Stewards) or paid in to the FIM Executive Secretariat (appeal before the CDI), as the case may be.

Within 10 days following the statement of appeal before the CDI, the appellant assigns to the FIM Executive Secretariat a brief of appeal stating the facts.

If the appeal was not lodged and/or the security deposit for appeal not paid within the dead line specified in article 3.4.6, the appeal will be declared inadmissible without hearing.

#### **3.4.7.1 Security deposit for appeals**

The amount of the security deposit is **1'200 €**

Teams and riders contracted to compete in the Championships may submit a letter of guarantee from IRTA in lieu of payment.

#### **3.4.7.2 Security deposit payable upon an adjournment**

If an adjournment to call further witnesses is ordered upon the request of one of the parties involved, this party must provide an additional financial guarantee within a time limit to be fixed by the disciplinary body. The hearing will not be continued until this guarantee has been paid. In case of no provision of the guarantee within the time limit, the disciplinary body will make a determination on the appeal based on the evidence of the original witness.

#### **3.4.7.3 Time limits to be observed for appeal hearings**

The FIM Stewards must be convened to examine an appeal immediately after the brief of appeal is received.

The CDI must be convened to examine an appeal not later than 6 weeks after the brief of appeal is received.

The FIM Stewards and the CDI must in all cases pronounce a decision.

#### **3.4.8 Effect of an appeal**

On request of the appellant, the FIM Stewards Panel may decide a stay of the provisional execution adjudicated by the Race Direction by injunction or in its decision.

On request of the appellant, the International Disciplinary Court (CDI) may decide a stay of the provisional execution adjudicated by the FIM Stewards Panel by injunction or in its decision.

### **3.5 Procedure before all the Disciplinary and Arbitration Bodies**

#### **3.5.1 Right to a hearing**

It shall be the unquestionable right of any person or body charged with any offence under the Regulations to defend themselves, either in person or by proxy.

Any party convened before a disciplinary or arbitration body has the right to be represented by one defense counsel of its own choice and at its own expense. Adequate notice of this intention must be given in order that this may also be notified to all other parties in the case. Failure to do so may result in the disciplinary or arbitration body upholding an objection to such representation.

If any of the parties duly convened do not appear, judgment can be rendered by default.

The disciplinary or arbitration bodies may decide that the hearing take place by means of a telephone conference call or through any other means of communication using a telephone or electronic device. Such a method of conducting a hearing shall only take place with the consent of all parties involved.

#### **3.5.2 The hearing**

The hearing shall be public unless the disciplinary or arbitration body itself decides otherwise in exceptional circumstances.

The hearing shall be conducted in one of the official languages of the FIM. Should one of the parties wish to use another language, it shall provide the necessary interpreters at its own costs.

The appellant must be present or duly represented, failing which, the protest will not be admissible and the costs shall be borne by the appellant.

Once the President has opened the proceedings, he will invite the parties involved to state their respective cases without the witnesses being present.

After statements of the parties concerned, the disciplinary or arbitration body shall hear the various witnesses and experts in order to complete the evidence. The parties involved in the case shall have the right to question all witnesses and experts on their evidence.

Any member of the disciplinary or arbitration body may, at any time during the hearing and with the President's approval, question any of the parties involved, the witnesses and experts.

### **3.5.3 Witnesses and Experts**

Each party is responsible for the convening and appearance of its own witnesses, as well as their expenses unless decided otherwise by the Court.

The disciplinary or arbitration body has no authority to oblige the witnesses to swear on oath; therefore, testimony shall be given freely. The witnesses may only testify to the facts they know and shall not be allowed to express an opinion, unless the disciplinary or arbitration body should regard them as experts on a particular subject and should ask them to do so.

After having made their statements, the witnesses may not leave the Courtroom and shall not be allowed to speak to any other witness who has still to give evidence.

The Court may summon experts.

### **3.5.4 Judgement**

Decisions of all disciplinary or arbitration bodies will be reached in camera by a simple majority of votes (exception : See Art. 1.6.4 "Race Direction"). All members will have equal voting rights which must be exercised when a decision is required. Abstention is not permitted.

Each member of the disciplinary or arbitration body binds himself to keep all deliberations secret.

### **3.5.5 Notification of judgements**

The decisions of the Race Direction or of the FIM Stewards must be notified directly at the event venue, or failing that, addressed by registered letter with acknowledgement of receipt.

All judgements of the International Disciplinary Court (CDI) must be notified, in writing, by registered letter with acknowledgement of receipt in order to inform all the parties concerned.

### **3.5.6 Publication of judgements**

The disciplinary or arbitration body imposing a penalty or adjudicating a protest or an appeal must have its findings published and quote the names of all parties concerned. The persons or bodies quoted in these statements have no right of action against the FIM nor against any person having published the statement.

Furthermore, final decisions will be published in the Media Centre and in the FIM Magazine unless the Court itself decides otherwise.

### **3.6 Costs of procedure**

The costs of a disciplinary or arbitration decision will be assessed by the FIM Executive Secretariat and will be awarded against the losing party, unless the Court decides otherwise.

#### **3.6.1 Payment of fines and costs**

If the penalty is definitive, all fines must be paid into the Benevolent Fund before the beginning of the first practice of the second Grand Prix following the final decision. The costs must be paid to the FIM Executive Secretariat within 30 days of notification of the judgement decision according to Article 3.5.5.

The person or body affected by the decision shall be automatically suspended from participation in all FIM activities, until such time as full payment has been received.

### **3.7 Reciprocity of penalties**

As a consequence of the agreement of reciprocity concluded on April 30th, 1949 between the 4 organisations controlling motorised sports internationally, i.e. in addition to the FIM, namely:

- the Fédération Internationale de l'Automobile (FIA)
- the Fédération Aéronautique Internationale (FAI)

- the Union Internationale Motonautique (UIM)

penalties of suspension or exclusion may also be applied to one or another of the sports represented by the above organisations, upon request of the FIM.

### **3.8 Law of Mercy**

The Management Council, after consultation with the CJI President or upon his proposal, may mitigate or completely forgive the penalty of a person or group of persons after having exhausted all the appeal procedures

### **3.9. Arbitration Clause**

Final decisions made by the disciplinary bodies (**exception art. 3.4.2.3**) or the General Assembly of the FIM may be submitted exclusively to the Court of Arbitration for Sport by way of appeal within the time limit as laid down in article 3.4.6, which shall have exclusive authority to impose a definitive settlement in accordance with the Code of Arbitration applicable to sport.

#### **4. CIRCUIT STANDARDS**

Circuit standards will be defined by the "FIM Standards for Road Racing Circuits" (SRRC).

## **5. MEDICAL CODE**

### **5.1 INTRODUCTION**

The new FIM Anti-Doping Code (included in these rule book) came into force on 1 July 2004.

### **5.2 SPECIAL MEDICAL EXAMINATION**

At any time during an event a special medical examination may be carried out by an official doctor or by another doctor nominated by the Chief Medical Officer (CMO) at the request of the Race Director or Medical Director.

#### **5.2.1 Refusal to undergo Special Medical Examination**

Any rider who refuses to submit himself to such special medical examination must be excluded from the event, and his case notified to the FIM.

#### **5.2.2 List of medically Unfit Riders**

The CMO shall examine all riders listed as medically unfit who wish to compete in order to assess their medical fitness to do so the day before they use a motorcycle on the track. The list shall be supplied by the Medical Director who may attend this examination.

#### **5.2.3 Riders with Special Medical Requirements**

Riders with certain medical conditions and who may require special treatment in the event of injury, or who have been in hospital during the previous 12 months or who are being treated for any medical conditions are responsible for informing the Medical Director/CMO before the event that they may require such special treatment.

### **5.3 MEDICAL SERVICES AT EVENTS**

Any treatment at the circuit during an event is free of charge to the riders. The costs for transferring an injured rider to a hospital designated by the CMO are the responsibility of the organiser or promoter of the event.

Medical services must guarantee assistance to all riders as well as any other authorised persons injured or taken ill at the circuit during event.

A medical service for the public, separate from the above services must be provided by the event organisers. This service is not described in this code but must conform to any regulation enforced by the relevant country and reflect the size of crowd expected.

Both medical services must be controlled by a single CMO.

Adequate medical services should be available continuously, from at least 08.00 hrs. on the day the paddock opens for the teams, until at least 20.00 hrs. on the race day.

### **5.3.1 Terms of reference of the CMO:**

The CMO:

- Is holder of the corresponding FIM official's licence.
- Is appointed by the FMNR/Organiser.
- Should be the same throughout the event.
- Must be able to communicate in at least one of the FIM official languages, either English or French.
- Should be familiar with the FIM Medical Code and FIM Anti- Doping Code.
- Must be named in the event information.
- Must be a fully registered medical practitioner authorised to practice in the relevant country or state.
- Must have malpractice insurance appropriate to the relevant country or state, where the event is being held.
- Is responsible for the positioning of medical and paramedical personnel and vehicles under his control.
- Is responsible for the positioning of medical and paramedical personnel and vehicles under his control.
- Must brief the medical personnel prior to the start of the first practice session of the event, as well as debrief the staff after the event.
- Must provide the Medical Director with a circuit map showing the position of the medical personnel and vehicles.
- Must with the Medical Director and FIM Medical Observer (if present) inspect all medical services not less than 30 minutes before the start of practice and racing each day of the event to ensure that all services and staff are in their correct place and ready to function, including the Medical Centre.
- Must inform and update the Medical Director and the Race Director regarding the condition of injured riders who are in the hospital.
- Will prepare a list of injured riders (MEDICALLY UNFIT LIST) to be given to the Medical Director and FIM Medical Observer (if present).

- Shall ascertain that fallen riders during practice are medically fit to continue in competition. All riders injured during an event who avoid a Medical examination must be placed on the medically unfit list.
- Can recommend to the Race Director/Clerk of the Course that a race be stopped if:
  - There is danger to life or of further injury to a rider or officials attending that rider if other riders continue to circulate.
  - There is a risk of physiological damage to riders or of inability by riders to control their machines, due to extreme weather conditions.
  - The Medical personnel is unable to reach or treat a rider for any reason.
- Must be stationed in race control, whenever bikes are on the track.
- Must complete the FIM CIRCUIT CMO QUESTIONNAIRE (Appendix F) and return it to the FIM at least 60 days prior to the event.
- Must contact, in writing, at least 60 days before the event, hospitals in the vicinity of the event that are able to provide the following specialist services:
  - Trauma resuscitation
  - Neurosurgery
  - General surgery
  - Vascular surgery
  - Trauma and Orthopaedic surgery
  - Cardio-Thoracic surgery
  - Intensive Care
  - Burns and plastic surgery
- Must send copies to the Medical Director and to the FIM at least 30 days before the event by FAX or E-MAIL of the letters they have written to the hospitals and copies of the letters of confirmation that every hospital to be used for treatment of injured persons is aware that the event is taking place and, is prepared to accept and treat injured riders with minimum delay. The letter of confirmation of every hospital must mention its equipment (x-ray, scanner etc..) the name (and telephone numbers) of the doctor in charge for each day and a map showing the shortest way from the circuit to the hospital. Any change to the above mentioned information must be immediately forwarded to the Medical Director and to the FIM.  
An interpreter in English must be available in the hospital permanently when an injured rider is there.
- Must make every effort to ensure that a rider may be released from the hospital when he wishes by signing an official self discharge form.
- May attend the meetings of the Event Management Committee.

### **5.3.2 Medical Director**

The Medical Director will be appointed by the Contractual Partner.  
His duties shall be:

- To receive from the CMO a signed copy of the FIM Circuit Medical Report Form and to ensure that the facilities comply with it.

- To inspect the circuit with the CMO the day before the first practice session. A further check will be made no later than 30 minutes before each days practice session or race to ensure that medical facilities are in accordance with this code, and to report any shortcomings to the Race Director and FIM Safety Officer.
- To obtain from the CMO at the end of each practice session or race a list of fallen riders and to ensure that the list of medically unfit riders held by the Medical Director is up to date to ensure medically unfit riders are not allowed on the circuit.
- To attend serious incidents with the CMO or his nominated deputy and render such assistance as may be necessary. A car should be available in the pit lane near the Race Control to allow this.
- To examine with CMO all riders listed as injured (Unfit Riders List) who wish to compete to assess their medical fitness to do so.
- To attend Event Management Committee Meetings.

### **5.3.3 FIM Medical Observer**

The FIM Medical Observer at an event will be a member of the FIM Medical Panel.

The duties of the FIM Medical Observer at an event will be:

- To observe and advise the application of the Medical Code
- To inform the Medical Director and if necessary the Race Direction of any medical arrangement that contravenes the Medical Code.

### **5.3.4 Other Doctors**

Any injured rider must first be seen and assessed by the official event medical personnel for emergency treatment and be declared medically fit or unfit to compete as appropriate. He may then attend any other doctor of his choice. If the CMO advises against this, the rider must sign a declaration that he is seeking other advice and treatment.

Any rider, who, after treatment by a doctor not part of the event team, wishes to compete, must first obtain authorisation for this from the CMO of the event or his deputy, who should consider any recommendation by the doctor treating him.

### **5.3.5 CLINICA MOBILE**

For many years the CLINICA MOBILE, or its personnel, under the direction of Dr. Claudio Costa, has attended Grand Prix events and has gained a considerable reputation among riders and support staff.

The CLINICA MOBILE has X-ray and treatment facilities and its staff have considerable experience in treating riders' injuries and illness. Many riders prefer

treatment by the CLINICA MOBILE staff to treatment by others. The parties involved in the Championship fully support the CLINICA MOBILE staff and the CLINICA MOBILE will be in attendance at events with the full co-operation of event organisers and CMOs.

The CLINICA MOBILE staff will treat those riders who wish to be treated by them only after they have been seen by the CMO. The CMO should declare riders medically fit or unfit as normal, after which they may go to the CLINICA MOBILE if they wish. The CLINICA MOBILE staff will give a medical report to the CMO after assessment and treatment. A rider who has been declared medically unfit to race, who after treatment by the CLINICA MOBILE staff then wishes to race, must present himself back to the CMO for re-examination.

A rider who prefers treatment by the CLINICA MOBILE staff when advised by the CMO otherwise is entitled to take his own course of action, but should sign a form indicating it was against local medical advice. If the rider decides he wishes to be treated in a hospital of his own choice, the CMO, using the means at his disposal at the circuit (ambulance, helicopter, etc.) must allow the rider to reach such hospital: i.e. the rider must be allowed to be transported by ambulance or helicopter from the circuit to the nearest airport.

In case of transfer to the hospital a doctor of the CLINICA MOBILE will accompany the rider.

### **5.3.6 Qualification of medical personnel**

#### **5.3.6.1 Qualification of doctors**

Any doctor participating at an event:

- must be a fully registered medical practitioner.
- authorised to practice in the relevant country or state.
- qualified in and able to carry out emergency treatment and resuscitation.

#### **5.3.6.2 Qualification of paramedics or equivalent**

Any paramedic **or equivalent** participating at an event:

- must be fully qualified and registered as required by the relevant country or state.
- must be **experienced in emergency care**.

#### **5.3.6.3 Identification of medical personnel**

All medical personnel must be clearly identified.

All doctors and paramedics must wear a garment clearly marked with "DOCTOR" or "DOCTEUR" and "MEDICAL" respectively, preferably in red on a white background on the back and on the front.

### **5.3.7 Medical Equipment**

#### **5.3.7.1 Minimum medical requirements for events**

**The medical service comprising of equipment, vehicles and personnel must be organised in such a way and in sufficient number to ensure that an injured rider can be provided with appropriate and all necessary emergency treatment with the minimum of delay and to facilitate their rapid transfer to further medical treatment in an appropriately equipped medical centre or definitive medical care in a hospital with the necessary facilities to deal with their injuries or illness should this be required.**

**The CMO will therefore determine the number, location and type of vehicles, helicopter, equipment and personnel that are required to achieve this for a specific event taking into consideration the circuit, event location.**

**The minimum medical requirements will be subject to confirmation and agreement following inspection and review by the FIM Medical Observer and Medical Director.**

**A doctor or doctors must be available to provide initial medical intervention directly or following initial assessment and treatment by the paramedic teams.**

In all cases, the transfer of an injured rider to a medical centre or hospital either by ambulance or by helicopter must not interfere with the event and the CMO must plan to have sufficient replacement equipment available to allow the event to continue.

- Vehicles type A are to be placed in such a way and in such numbers that a fallen rider can be reached within 2 minutes after coming to rest.
- Vehicle(s) type B (number as per the FIM Medical Homologation) are to be placed in such a way that a fallen rider can be reached with minimum delay after coming to rest.
- Vehicle(s) type C (number as per the FIM Medical Homologation) are to be placed in such a way that a fallen rider can be reached with minimum delay after coming to rest.
- Track Ground posts
- Pit lane ground post

- A Medical Centre
- A helicopter

N.B. the only replacement allowed to these requirements is a vehicle Type B may replace a vehicle Type C

### **5.3.7.2 Vehicles**

#### **5.3.7.2.1 Definition of Vehicles**

Vehicles are defined as follow:

**Type A:** A vehicle for rapid intervention at accident areas to give the injured immediate assistance for respiratory and cardio-circulatory resuscitation.

This vehicle should have “**MEDICAL**” clearly marked on it in large letters.

**Type B:** A highly specialised vehicle that can serve as a mobile resuscitation centre.

**Type C:** A vehicle capable of carrying a stretcher with an injured person in reasonable conditions.

#### **5.3.7.2.2 Equipment for Vehicle Type A (Medical Rapid Intervention Vehicle)**

##### **Personnel:**

##### **Type A1:**

- a driver, experienced in driving **the Type A vehicle** and familiar with the course
- a doctor experienced in **emergency care**
- a second doctor or paramedic, experienced in **emergency care**

##### **Type A2:**

- a driver, experienced in driving **the Type A vehicle** and familiar with the course
- **paramedics (or equivalent) experienced in emergency care**

##### **Medical Equipment:**

- Portable oxygen supply
- Manual ventilator
- Intubation equipment
- Suction equipment

- Intravenous infusion equipment
- Equipment to immobilise limbs and spine (including cervical spine)
- Sterile dressings
- ECG monitor and Defibrillator
- Drugs for resuscitation and analgesia /IV fluids
- Sphygmomanometer and stethoscope

Equipment should be easily identified and stored in such a way that it can be used at ground level at the trackside.

**Technical:**

- Radio communication with Race Control and the CMO
- Visible and audible signals
- Equipment to remove suits and helmets

The minimum number of **medical rapid intervention vehicle** is 2.

**5.3.7.2.3 Equipment for Vehicle Type B**

**Personnel:**

**Type B1:**

- **A doctor experienced in emergency care**

**Type B2:**

- **Two paramedics or equivalent experienced in emergency care**

**Medical Equipment:**

- Portable oxygen supply
- Manual and an automatic ventilator
- Intubation equipment
- Suction equipment
- Intravenous infusion equipment
- Equipment to immobilise limbs and spine (including cervical spine)
- Sterile dressings
- Thoracic drainage equipment
- Tracheotomy equipment
- Sphygmomanometer and stethoscope
- Stretcher
- Scoop stretcher
- ECG monitor and defibrillator
- Pulse oximeter
- Drugs for resuscitation and analgesia/ IV fluids

### **Technical**

- Radio communication with Race Control and the CMO
- Visible and audible signals
- Equipment to remove suits and helmets
- Air conditioning and refrigerator are recommended

1 such ambulance must be on stand by at the Medical Centre.

### **5.3.7.2.4 Equipment for Vehicle Type C**

#### **Personnel:**

- Two ambulance personnel or paramedics of whom one would be the driver and the other would be a person capable of giving first aid

#### **Medical:**

- Stretcher
- Oxygen supply
- Equipment to immobilise limbs and spine (including cervical spine)
- First aid medicaments and materials

#### **Technical:**

- Radio communication with Race Control and the CMO
- Visible and audible signals

### **5.3.7.3 Helicopter**

A helicopter must be **fully equipped with adequate personnel and equipment and be** appropriately licensed for the relevant country and flown by an experienced pilot familiar with medical air evacuation and the potential landing sites. The medical personnel - doctor and paramedic(s) - should be qualified in and able to carry out emergency treatment and resuscitation. The helicopter should be of a design and size that will allow continuing resuscitation of an injured rider during the journey. It should be positioned close to the medical centre such that an ambulance journey between medical centre and helicopter is not necessary.

### **5.3.7.4 Track Ground Posts**

These are placed at suitable locations **and in sufficient numbers** around the circuit to provide rapid intervention and evacuation of the rider from danger **with the minimum of delay**. The personnel must have sufficient training and experience to take action autonomously and immediately in case of an accident.

**Personnel:**

- Doctor or paramedic (**or equivalent**) experienced in **emergency care**
- Sufficient number of stretcher bearers

**Medical Equipment:**

- Equipment for initiating resuscitation and emergency treatment
- Cervical collar
- Scoop stretcher
- Technical Equipment:
- Radio communication with race control and the CMO

Adequate shelter for staff and equipment should be available.

**5.3.7.4.1 Pit Lane Ground Post****Personnel:**

A doctor and paramedic (**or equivalent**) experienced in **emergency care** must be positioned in the pit lane.

**One or more Pit Lane Ground posts, depending on the length of the pit lane are required.**

**Medical Equipment:**

- Airway management and intubation equipment
- Drugs for resuscitation and analgesia/ IV fluids
- Cervical collars
- Manual respiration system
- Intravenous Infusion Equipment
- First Aid Equipment
- Stretcher

**Technical Equipment:**

- Radio communication with race control and the CMO

**5.3.7.5 Medical Centres**

Refer to Art. 029.9.1 of the FIM Standards for Road Racing Circuits (SRRC).

**5.3.7.5.1 Equipment for Resuscitation Areas:**

- Equipment for endotracheal intubation, tracheostomy and ventilatory support, including suction, oxygen and anaesthetic agents

- Equipment for intravenous access including cut-down and central venous cannulation and fluids including colloid plasma expanders and crystalloid solutions
- Intercostal drainage equipment and sufficient surgical instruments to perform an emergency thoracotomy to control haemorrhage
- Equipment for cardiac monitoring and resuscitation, including blood pressure and ECG monitors and a defibrillator
- Equipment for immobilising the spine at all levels
- Equipment for the splinting of limb fractures
- Drugs/IV fluids including analgesic, sedating agents, anticonvulsants, paralysing and anaesthetic agents, cardiac resuscitation drugs/IV fluids
- Tetanus toxoid and broad spectrum antibiotics are recommended
- Equipment for diagnostic ultrasound is recommended
- A permanent or portable X-ray machine, appropriate to detect usual bone fractures in motorcycle sport, must be available.

#### **5.3.7.5.2 Equipment for minor injuries area:**

The area must have beds, dressings, suture equipment and fluids sufficient to treat up to three riders with minor injuries simultaneously. Sufficient stocks to replenish the area during the meeting must be available and sufficient Doctors and Paramedics experienced in treating trauma must be available.

#### **5.3.7.5.3 Staff of Medical Centre**

The following specialists should be immediately available in the medical centre:

- Trauma resuscitation specialist (e.g. Anaesthetist, Accident and emergency specialist, Intensive care specialist)
- Surgeon experienced in trauma

Nurses and paramedics in a sufficient number, should be experienced in resuscitation, diagnosis and treatment of seriously injured patients..

#### **5.3.7.6 Medical homologation of circuits / Medical inspection of events**

All circuits require medical homologation.

All circuits which have undergone significant changes in the layout or at the Medical Centre within the homologated period are required to renew homologation. The objective is to maintain the highest standard of services for the safety of the riders. This code will be used as the reference for the homologation inspections. Any request for renewal of homologation should be made by the FMN concerned.

The specific requirement for each circuit will be decided by the FIM Medical Inspector in collaboration with the Circuit CMO who has to be present according to the requirements of the Championships promoters and with reference to the Medical Code.

Following homologation, a certificate of homologation will be issued for a period of 3 years and will include details of medical services.

Sample drawings of Medical Centre models are available from the FIM Executive Secretariat for reference.

The FMN and the Organiser will be informed by the FIM if the circuit requires renewal of homologation.

The FIM also reserves the right to review such a homologation at any time.

### **5.3.8 Procedure in the event of an injured rider**

The management of an injured rider is under the control of the CMO and should be the following:

A fallen rider must be reached by a Doctor or Paramedic who can begin treatment within 30 seconds of the rider coming to rest. If the rider is injured, the CMO must be informed by radio so that further procedures can be initiated. It is recommended that the CMO be stationed in Race Control with access to Closed Circuit Television to monitor the situation. Upon request by the CMO any Medical Vehicle can be dispatched to the scene of the incident, only the Race Director can authorize entry onto, or response via track. Similarly, interruption or cessation of racing or practice session can only be authorized by the Race Director. It is the responsibility of the CMO and Medical Director to advise the Race Director of incidences where access to a fallen rider(s) necessitates this.

Response Codes are:

- |        |  |
|--------|--|
| Code 0 | No medical intervention required<br>Rider gets up unassisted   |
| Code 1 | Short Rescue<br>Rider able to walk with assistance<br>Rider will be cleared from track in less than 1 minute |
| Code 2 | Long Rescue<br>Rider requires stretcher<br>Rider will be cleared from track in less than 2 minutes           |

Code 3        Prolonged Rescue  
                 Rider(s) seriously injured  
                 Rider (s) requires stretcher  
                 Rescue will take longer than 3 minutes  
                 Medical intervention required on track

### **Transfer to the Medical Centre**

The injured rider will be transferred to the Medical Centre when his condition permits. The CMO shall decide the time and method of transfer. Rarely, at the discretion of the CMO only, a rider may be transferred to hospital directly from the trackside.

The vehicle used to transfer the rider must be on scene of the accident with minimum delay following the order to intervene.

### **Medical Centre**

At the Medical Centre, medical personnel will be available to treat the rider. The CMO remains responsible for the treatment of the rider.

If the rider is unconscious, he will be treated by the Medical Centre staff under the responsibility of the CMO. The rider's personal doctor may observe this treatment and may accompany the rider to hospital.

A rider who is conscious may choose the medical personnel by whom he wishes to be treated. A rider who does not wish to be treated by the Medical Centre staff against their advice must sign a "Competitor Self Discharge" Form.

### **Transfer to hospital**

The CMO shall decide the time of transfer, the mode of transfer and the destination of an injured rider. Having made the decision, it is his/her responsibility to ensure that the receiving hospital and appropriate specialists are informed of the estimated time of arrival and the nature of injuries. It is also the responsibility of the CMO to ensure appropriately skilled and equipped staff accompany the rider.

A doctor of the Clinica Mobile will accompany the rider.

## **5.4        MEDICAL MALPRACTICE INSURANCE**

All doctors and other medical personnel at an event must have adequate medical malpractice insurance cover.



**RIDER SELF DISCHARGE FORM**

**PART 1 : To be completed by the rider**

I, \_\_\_\_\_ rider no \_\_\_\_\_  
in the \_\_\_\_\_ class, discharge myself against local medical advise  
and understand the possible consequences.

Signed : \_\_\_\_\_ Date : \_\_\_\_\_ Time : \_\_\_\_\_

---

---

**PART 2 : To be completed by the Chief Medical Officer (CMO)**

I, Dr \_\_\_\_\_, CMO at the  
\_\_\_\_\_ circuit, confirm that I have  
explained the possible consequences of the rider discharging himself/herself.

In view of the language difficulties, this explanation was given through an  
interpreter (Delete if inappropriate).

Signed : \_\_\_\_\_ Date : \_\_\_\_\_ Time : \_\_\_\_\_

5 Copies : CMO, Rider, Clerk of the Course, Medical Director, Clinica Mobile

## **ANTI-DOPING CODE**

The regulations will be defined by the "FIM ANTI-DOPING CODE".

## **ENVIRONMENTAL CODE**

**The regulations will be defined by the “FIM ENVIRONMENTAL CODE”.**