



FÉDÉRATION INTERNATIONALE  
DE MOTOCYCLISME

**FIM SIDECAR  
WORLD CHAMPIONSHIP REGULATIONS**

**2017**

*RÈGLEMENTS DU  
CHAMPIONNAT DU MONDE FIM DE SIDECAR*



# FIM Sidecar World Championship Regulations



**EDITION 2017**

update 5 January 2017

**FÉDÉRATION INTERNATIONALE DE MOTOCYCLISME (FIM)**

11, route Suisse

CH - 1295 MIES

Tel: +41-22-950 950 0

Fax: +41-22-950 950 1

[www.fim-live.com](http://www.fim-live.com)

[victoria.corredoira@fim.ch](mailto:victoria.corredoira@fim.ch)

[paul.duparc@fim.ch](mailto:paul.duparc@fim.ch)

## CONTENTS

1.	Sporting Regulations for FIM Sidecar World Championship .....	1-48
	Supplementary Regulations .....	49-59
2.	Technical Regulations for FIM Sidecar World Championship .....	60-94
3.	Disciplinary and Arbitration Code.....	95
4.	Circuit Standards .....	96
5.	Medical Code .....	97
6.	Anti-Doping Code .....	98
7.	Environmental Code .....	99
8.	<b>Code of Ethics</b> .....	<b>100</b>
	Diagrams and appendices .....	101-108

Articles amended as from 1.1.2017 are in bold type



## FIM SIDECAR WORLD CHAMPIONSHIP REGULATIONS

<b>1.</b>	<b>SPORTING REGULATIONS.....</b>	<b>6</b>
	1.1 INTRODUCTION .....	6
	1.2 EVENTS .....	6
	1.3 THE PADDOCK .....	8
	1.4 OFFICIALS .....	8
	1.5 INTERNATIONAL JURY .....	11
	1.6 THE CALENDAR .....	12
	1.7 SIDECARS .....	12
	1.8 ELIGIBLE COMPETITORS .....	13
	1.9 SCHEDULE .....	16
	1.10 TECHNICAL CONTROL, MEDICAL CONTROL, DOPING CONTROL.....	17
	1.11 PRACTICE .....	18
	1.12 CHANGE OF PASSENGER .....	20
	1.13 GRID POSITIONS .....	20
	1.14 RACES.....	21
	1.15 START PROCEDURE.....	21
	1.16 RIDE THROUGH PROCEDURE .....	29
	1.17 “WET” AND “DRY” RACES.....	30
	1.18 BEHAVIOUR DURING PRACTICE AND RACE .....	30
	1.19 FLAGS AND LIGHTS.....	34
	1.20 MEDICAL CARS .....	39
	1.21 FINISH OF A RACE AND RACE RESULTS .....	39
	1.22 INTERRUPTION OF A RACE .....	41
	1.23 RE-STARTING A RACE THAT HAS BEEN INTERRUPTED.	42
	1.24 CHECK AREA/PARC FERMÉ .....	44
	1.25 PODIUM .....	44
	1.26 FINAL TECHNICAL CONTROL .....	45
	1.27 EXTRA DEPOSITS IN CASE OF SIDECAR CONTROL FOLLOWING A PROTEST .....	45
	1.28 DEPOSIT FOR FUEL CONTROLS FOLLOWING A PROTEST .....	45



1.29	SANCTION FOR NON-COMPLIANCE WITH THE FUEL RULES .....	46
1.30	CHAMPIONSHIP POINTS AND CLASSIFICATION .....	46
1.31	PRIZE-GIVING CEREMONY.....	47
1.32	INSTRUCTIONS AND COMMUNICATIONS TO COMPETITORS .....	48
<b>2.</b>	<b>TECHNICAL REGULATIONS .....</b>	<b>60</b>
2.1	INTRODUCTION .....	60
2.2	TECHNICAL SPECIFICATIONS OF CHASSIS, ELIGIBILITY REQUIREMENTS.....	60
2.3	TECHNICAL SPECIFICATIONS OF ENGINE, ENGINE INSTALLATION, ELIGIBILITY REQUIREMENTS .....	69
2.10	FUEL, OIL AND COOLANTS .....	75
2.11	PROTECTIVE CLOTHING AND HELMETS .....	81
2.12	PROCEDURE FOR TECHNICAL CONTROL .....	83
2.13	VERIFICATION GUIDELINES FOR TECHNICAL STEWARDS	86
2.14	SOUND CONTROL .....	91
2.15	GUIDELINES FOR USE OF SOUND LEVEL METERS .....	93
<b>3.</b>	<b>DISCIPLINARY AND ARBITRATION CODE .....</b>	<b>95</b>
<b>4.</b>	<b>CIRCUIT STANDARDS .....</b>	<b>96</b>
<b>5.</b>	<b>MEDICAL CODE .....</b>	<b>97</b>
<b>6.</b>	<b>ANTI-DOPING CODE .....</b>	<b>98</b>
<b>7.</b>	<b>ENVIRONMENTAL CODE.....</b>	<b>99</b>
<b>8.</b>	<b>CODE OF ETHICS.....</b>	<b>100</b>
	<b>DIAGRAMS AND APPENDICES .....</b>	<b>101</b>

## GENERAL UNDERTAKINGS AND CONDITIONS

Any references to the male gender in this document are made solely for the purpose of simplicity, and refer also to the female gender except when the context requires otherwise.

In the current Regulations, the word “rider” also means “passenger” unless articles are otherwise specified.

All riders, teams’ personnel, officials, organisers and all the persons involved in any capacity whatsoever participating in the FIM Sidecar World Championship (hereinafter referred to “Championship”) undertake, on behalf of themselves, their employees, and agents, to observe all the provisions of:

1. SPORTING REGULATIONS
2. TECHNICAL REGULATIONS
3. DISCIPLINARY AND ARBITRATION CODE
4. CIRCUIT STANDARDS
5. MEDICAL CODE
6. ANTIDOPING CODE
7. ENVIRONMENTAL CODE
8. CODE OF ETHICS

as supplemented and amended from time to time.

All the persons mentioned above may be penalised in accordance with the provisions of the FIM Sidecar World Championship Regulations (hereinafter referred to “Regulations”).

Whilst the Regulations may be translated into other languages, in case of any dispute regarding interpretation the official English text will prevail.

It is the responsibility of the team to ensure that all persons concerned with its entry observe all the requirements of the Regulations. The responsibility of the rider, or any other person having charge of an entered Sidecar during any part of the event with respect to observance of the Regulations, is joint and several with that of the team.

All persons concerned in any way with an entered Sidecar or present in any capacity whatsoever in the paddock, pits, pit lane or track, shall wear an appropriate pass at all times during the event.



---

## ANTIDOPING CODE

All the persons concerned shall at all times observe the FIM Anti-Doping Code and may be penalised accordingly.



---

## SUPPLEMENTARY REGULATIONS

In special circumstances, the FIM may allow the Organiser of individual event to mention in the Supplementary Regulations particular provisions not included in or different from the current Regulations.

## **1. SPORTING REGULATIONS**

### **1.1 INTRODUCTION**

#### **1.1.1**

A series of races counting toward the FIM Sidecar World Championship for riders will be organised.

#### **1.1.2**

Official documents relating to a meeting shall conform to article 100.5 of the FIM Sporting Code.

### **1.2 EVENTS**

#### **1.2.1**

The event shall be deemed to commence at the scheduled time for Technical and Sporting Checks and finish after all the races at the expiry of the deadline for the lodging of a protest and the time, at which technical or sporting verifications have been concluded, whichever is the latest.

The Race Control shall remain operative with all equipment in place until the end of the period provided for the lodging of a protest, and all Officials and marshals shall remain at the circuit available to the International Jury during that period.

#### **1.2.2**

Events shall be staged on race circuits that have been homologated by the FIM for the Championship.

#### **1.2.3**

Events shall not include any other races except for support races approved by the FIM which may not alter the event schedule (1.11).

#### 1.2.4

Any activity involving 4 wheels racing vehicular use of the track during the event, including “demonstrations”, displays or the suchlike shall receive prior approval from FIM.

#### 1.2.5

Organisers will be nominated by the FIM.

#### 1.2.6

The Organiser is responsible for providing the facilities and personnel to ensure the smooth and efficient running of the event.

#### 1.2.7

The Organiser shall obtain insurance for third party liability according to article 110.1.1 of the FIM Sporting Code.

#### 1.2.8

At least 90 days prior to the event, the Organiser of the event shall submit the following information to the FIM:

- a) Confirmation of the name and address of the Organiser, including telephone and facsimile numbers for correspondence.
- b) The date and place of the event.
- c) A detailed plan of the circuit, its direction, clockwise or anticlockwise, and length.
- d) The location at the circuit of the teams and riders information centre and the official notice board.
- e) The name and address of the company providing the third party liability insurance cover and the number of the policy.
- f) Name and address of FMNR.
- g) The name of the Clerk of the Course and the name of the 3<sup>rd</sup> (FMNR) Jury member (with appropriate FIM licence).
- h) The name, address and telephone number of the Chief Medical Officer.

- i) The name, address and telephone number of the hospitals designated for the event.
- j) The Supplementary Regulations for the event in English and French (see appendix).

## **1.3 THE PADDOCK**

### **1.3.1**

The paddock, pit boxes and all other facilities shall be available to teams at least on the day prior to the first practice day and remain available to competitors for at least one day after the event.

### **1.3.2**

Access shall be available for teams arriving to set up between the hours of 08:00 and 20:30.

### **1.3.3**

At all times that the paddock is occupied there shall be a basic medical service and firefighting service in the circuit.

A fire truck shall be provided with the following minimum characteristics: Tank capacity 4 cubic meters; pressure: 40 kg/cm<sup>2</sup> (high), 12 kg/cm<sup>2</sup> (low); water rate 300 - 400 litres/minute.

## **1.4 OFFICIALS**

### **1.4.1**

All the following Officials shall be present and available at the time necessary to ensure smooth and efficient running of the event.

### **1.4.2**

Refer to article 40 of the FIM Sporting Code.

### 1.4.3

The following Officials will be appointed for individual events to perform supervisory and executive roles.

A) Officials appointed by the FIM:

1. The President and two members of the International Jury (with appropriate FIM Sporting Steward licence). They are responsible for ensuring that the event is conducted according to the Regulations.

The International Jury President is responsible for the supervision of all aspects of safety.

2. The FIM Technical **Director**

Responsible for:

**Ensuring** that Technical Regulations are correctly enforced and supervising scrutineering and protests of a technical nature.

B) Officials appointed by the FMNR/Organiser:

3. Clerk of the Course (**with appropriate FIM licence**)

Responsible for:

- a) Ensuring that the circuit is suitably prepared for and maintained during the event and that all legal requirements applicable for the running of the event have been complied with.
- b) Ensuring that all Officials and services are in place.

The stationing of all track personnel and equipment (i.e. marshals, fire-fighting services, Moto-taxi, recovery/intervention vehicles, flags, etc.) alongside the circuit no later than 30 minutes prior to the beginning of all practice sessions and warm-ups.

Once the morning Medical Inspection is finished, medical personnel should stand 5 meters behind the track marshals or leave. Only sportive personnel should stay at the edge of the track for the “sporting” inspection.



The Jury President, the Clerk of the Course and the Chief Medical Officer will make the final inspection of the circuit to ensure this regulation is complied with, 30 minutes prior to the beginning of the day's first practice sessions and/or warm up.

During the final inspection lap, the Yellow Flag shall be waved at each flag marshal post together with the display of other flags and equipment requested by the Jury President.

- c) Taking decisions to ensure the smooth and efficient running of the event.
- d) Ensuring that the event is run within the Regulations.
- e) Notification of protests to the International Jury.
- f) The control of practice and the race, adherence to the timetable and, if he deems it necessary, the making of any proposal to the International Jury to modify the timetable in accordance with the Sporting Regulations.
- g) The stopping of practice or the race in accordance with the Sporting Regulations if he deems it unsafe to continue and ensuring that the correct restart procedure is carried out.
- h) The starting procedure.
- i) The use of safety cars/fast interventions vehicles.
- j) Immediate approval and signature with time of provisional results (practices, warm-ups, starting grids and races) and presentation of reports to the International Jury.

## 5. Secretaries

Responsible for:

- a) During the event effecting communications between the various Officials.
- b) Providing secretarial support for the International Jury.

## 6. Other Officials

The Chief Technical Steward shall be holder of the FIM Technical Steward licence.

#### 1.4.4

All communications between Officials appointed by the FMNR/Organiser shall be made via the relevant FIM Officials.

### 1.5 INTERNATIONAL JURY

#### 1.5.1

Refer to article 50.1 of the FIM Sporting Code.

#### 1.5.2

The International Jury will meet at any time required during the event, but at least:

- a) Prior to the first practice session.
- b) At the end of each practice day.
- c) At the end of the event.

#### 1.5.3

The duties of the International Jury are:

- a) To amend the Supplementary Regulations if necessary.
- b) To take decision as provided in the Regulations.
- c) To ensure the smooth and efficient running of the event.
- d) A change in the conduct and/or format of a practice session and/or a race based on safety considerations and provided that such decision is absolutely necessary to resolve a situation not foreseen in the Regulations. In such exceptional cases, such decision may prevail over specific provisions of the Regulations.
- e) Provided that it is absolutely necessary to resolve a situation not foreseen in the Regulations, the International Jury may issue pre-race instructions or clarifications and in specific cases even create pre-race regulations (e.g. to take into account the local conditions at a particular circuit). However, such actions may only be taken within the limits set out by the Regulations, respectively the FIM Statutes.

- f) To receive reports from the various Officials concerning scrutinizing, practice and races.
- g) To confirm the practices and races results.
- h) To make recommendations to the Organiser to improve the smooth and efficient running of the event.
- i) To impose penalties for any infringements of the Regulations occurring during the event.
- j) To impose penalties on Organisers for having been unable to ensure the smooth and efficient running of the event or for serious breaches of the Regulations.
- k) To adjudicate on any protest relating to infringements of the Regulations occurring during the event.

No protest and no appeal to the CAS may be lodged against a decision of the International Jury entailing or not:

- a drop of position
- a Ride Through
- a disqualification from the practice sessions or races by means of a Black Flag or Black Flag with Orange Disc
- a fine for speeding in the pit lane

No protest and no appeal to the CAS may be lodged against a decision of the International Jury based on a photo finish.

## **1.6 THE CALENDAR**

### **1.6.1**

The calendar of races counting for the Championship will be, in principle, published by no later than 31<sup>st</sup> October of the preceding year.

## **1.7 SIDECARS**

### **1.7.1 Classes**

The class admitted for the FIM Sidecar World Championship will be Superside with a 600cc, 4 stroke, 4 cylinder engine, with a valid FIM Supersport/ Superstock 600cc homologation.

## 1.7.2 Means of propulsion

A Sidecar shall only be propelled by its own motive power, the muscular effort of its rider and by the natural forces of gravity.

## 1.8 ELIGIBLE COMPETITORS

### 1.8.1 Licences and Start Permissions

The riders shall be in possession of the adequate FIM Sidecar World Championship Licence issued by a FMN. Licences are issued to riders designated and can, in certain circumstances, be for a single event. To receive a licence, the rider shall be in possession of a national licence of a FMN at no additional cost to the rider.

Licenses are issued only when the minimum age has been attained as below:

- Driver: 18 years
- Passenger: 16 years

The limit for the minimum age starts on the date of the rider's birthday.

**Furthermore, all teams must be holder of the FIM Sporting Team Licence as described in the Art. 70.2.4 of the FIM Sporting Code.**

### 1.8.2 Entries

All entries must be made in writing on an entry form on which all information regarding the rider, teams, sponsor, chassis make and engine of the Sidecar shall be indicated.

The entry form shall be printed in **one of two** official languages of the FIM and shall mention Art. 60.5 of the Sporting Code.

Riders must have a permission to take part in the event delivered by their FMN.

**Entries for “permanent” teams shall be received by the FIM Administration the latest two (2) month before the first event of the season.**

**Entries for “one event” teams shall be received by the Organisers one (1) month before the event concerned, but, in the case of “force majeure”, may be modified up until the scrutineering.**

**The organisers can request a template for registration form at the FIM Administration.**

A compulsory briefing for all riders will be organised before the beginning of the 1<sup>st</sup> official practice session.

Failure to attend the briefing in full may result a penalty.

A waiver may be granted by the Jury President.

The licenses of the riders will be checked.

### **1.8.3 Contracted riders**

#### **1.8.3.1**

30 days before the first event of the season, the FIM will publish a list of contracted riders. This list may be updated until the day preceding the 1<sup>st</sup> session of the official practice.

#### **1.8.3.2**

Each contracted rider commits himself to compete in all the remaining events and must have an annual licence. Exception may only be made as follows:

The passenger can have a one event licence.

A rider or passenger may withdraw from additional events for medical reasons only or other reasons of “Force Majeure”.

Withdrawal must be announced to FIM Administration as soon as possible and must be approved by the FIM.

### **1.8.4 Acceptance**

The entries shall be made according to the following priority:

- Before the 1<sup>st</sup> event of the Championship:
  - The riders under contract
  - The riders having obtained points in the Championship of the previous year
  - Other riders
- After the 1<sup>st</sup> event of the Championship:
  - The riders under contract

- The riders having obtained points in the Championship of the current year at the closing date of entries
- Other riders

### 1.8.5 Entry fee

An entry fee may be made **mandatory** for each team.

Should this be the case;

For permanent riders and passengers:

- The amount is fixed at 2000 €uro for both (for the whole Championship).  
**This amount** must be paid to the FIM Administration 30 days at the latest before the first race of the season.

For “one event” riders and passengers:

- The maximum amount is fixed at 500 €uro for both (per event).  
**This amount** must be paid directly to the organisers 30 days at the latest before the race.

### 1.8.6 Starting Numbers

The contracted riders will have a permanent number.

The organisers will allocate the numbers to the other riders.

Riders who have scored points during the season will have priority on other teams for keeping their numbers during the full season.

The final decision of the Starting Number is subject to the FIM approval.

### 1.8.7 Non-participation in an event

Any rider who enters an event shall inform the organiser if, subsequently, he decides not to participate in the event. A rider who has submitted an entry form and fails to participate will be reported by the International Jury to the FIM, who will impose the following penalties:

- First offence: fine of 150 €
- Subsequent offences in the same season: Suspension from the next event counting towards the Championship

Upon receipt of the International Jury's report, the FIM Administration will send a letter to the rider's FMN asking the reasons for the non-participation; a reply should be sent within 15 days at the latest and a decision will be taken regarding the penalty.

An exclusion could also be pronounced against a rider who takes part in another event on the same day.

### **1.8.8 Withdrawal from an event**

A rider may withdraw from an event which has already started, due to injury, irreparable damage to the Sidecar(s) or in case of "Force Majeure".

Withdrawal shall be approved by the International Jury.

### **1.8.9 Participation in an event**

A rider shall be deemed to have taken part in the event when he participates in, at least, one practice session.

### **1.8.10 Participation in the race**

A rider shall be deemed to have started a race when he participates in, at least, the first lap of the race.

## **1.9 SCHEDULE**

Unless the Supplementary Regulations provide otherwise, it is recommended that the practices take place as follows:

### **1ST DAY:**

**ARRIVAL/SETTING UP OF TEAMS AND SCRUTINEERING/  
ADMINISTRATIVE CONTROLS**

### **2<sup>ND</sup> DAY: SCRUTINEERING AND ADMINISTRATIVE CONTROLS**

FREE PRACTICE	20 to 40 minutes
Interval	60 minutes
QUALIFYING PRACTICE	20 minutes
Interval	30 minutes
QUALIFYING PRACTICE	20 minutes

**3<sup>RD</sup> DAY:**

GOLD RACE	minimum 70 km maximum 85 km
COURSE SPRINT (option)	minimum 35 km maximum 45 km

All the riders and teams shall be immediately and in writing informed of any schedule change.

The above schedules may only be varied as follows:

- i) Prior to the event by the FIM
- ii) During the event by the International Jury

The schedule may include an allotted time for riders and teams to make familiarisation laps by bicycle or by foot. All traffic at this time must be in the circuit direction.

## **1.10 TECHNICAL CONTROL, MEDICAL CONTROL, DOPING CONTROL**

### **1.10.1**

All Sidecars should be checked by the Technical Stewards prior to first participation in practice on safety aspects, according to the published schedule.

Teams may present more than one Sidecar for Technical Control which will be specially identified by the technical controllers.

Unless a waiver is granted by the International Jury, teams who do not comply with the schedule for Technical or Medical Controls will not be allowed to take part in the event.

### **1.10.2**

The procedure for Technical Control is described in the Technical Regulations, articles 2.12 and 2.13.

The procedure for Medical Control is described in the FIM Medical Code.

### 1.10.3

Any rider to be tested for doping control shall report to the doping control room in the Medical Centre with sufficient identification within one hour of notification.

One associate may accompany the rider.

## 1.11 PRACTICE

### 1.11.1 Practice Sessions (warm-up included)

- i) Riders will commence practice from the pit lane when the Green Light is on and the Green Flags are waved at the exit of the pit lane.
- ii) The duration of practice will commence from the illumination of the Green Light. A visible board or count-down will be shown in the pit lane to indicate the minutes of practice remaining.
- iii) The end of practice will be indicated by the waving of a Chequered Flag at which time the pit exit will be closed. A rider's time will continue to be recorded until he passes the finish line after the allotted time has elapsed. After the Chequered Flag riders may complete one additional lap prior to entering the pits.
- iv) If practice is interrupted due to an incident or any other reason, then a Red Flag will be waved at the start line and at all marshals posts. All riders shall return slowly to the pit lane. When practice is restarted, the time remaining will be that shown on the count-down device in the pit lane and on the monitors of the official timekeepers at the moment the Red Flags were displayed.
- v) Riders or mechanics may only start their Sidecars in the pit lane by pushing in the direction of the circuit.

- vi) During all then event, once the practice has started, nobody can alter the condition of the racing surface of the circuit in response to a localised change in conditions. Even track marshals cannot clean the track without prior instructions and/or authorisation of the International Jury President and the Clerk of the Course.

#### **1.11.2 Lap time**

All laps of the riders will be timed.

A new lap record for a circuit may only be established by a rider during a race.

Both for practice and for race, the lap time is the subtraction of the time between two consecutive crossings of the finish line painted on the track.

#### **1.11.3 Qualifying practices results**

The results will be based on the fastest time recorded by the riders in all qualifying practices.

In the case where all qualifying practices have been cancelled, the results will be based on the fastest time recorded by the riders in all free practice sessions.

In the event of a tie, riders' second and subsequent best times will be taken into account.

#### **1.11.4 Qualification for the race**

To qualify for the race, a rider shall achieve a time at least equal to 115 % of the time recorded by the fastest rider in at least one qualifying session.

Any rider who fails to achieve a qualifying time will be permitted to take part in the race provided that in any of the free practice sessions he/she has achieved a time at least equal to 115 % of the fastest rider in same session.

Such riders will start the race from the back of the grid, in order of their free practice times.

Exemptions may be granted by the International Jury.

## 1.12 CHANGE OF PASSENGER

During practice, it is possible to change the passenger only once.

This change shall be immediately notified to the International Jury President who in turn will inform the timekeeping service.

A change of passenger with another driver is only possible if the driver agrees.

The time made with the 2<sup>nd</sup> passenger will be valid for the qualification.

The sidecar driver may run the race, if he is qualified, only with the 2<sup>nd</sup> passenger.

## 1.13 GRID POSITIONS

### 1.13.1

Grid positions will be based on the qualifying practice results or according to article 1.9.1.

### 1.13.2

At the International Jury meeting on the day proceeding the race day, a provisional starting grid will be established.

### 1.13.3

The grid will be arranged in 3-2-3-2-3 configuration “in echelon” if not specified differently in the Homologation Report.

Each line will be offset. There will be a distance of 9 metres between each row.

### 1.13.4

The pole position, allocated to the faster rider, will be determined during the Homologation of the Circuit.

### 1.13.5

The final grid will be published at the latest one hour before the start of the race.

## 1.14 RACES

### 1.14.1 Distance

The length of races shall be according to Art. 1.9 and will be determined by the FIM after publication of the calendar.

### 1.14.2

The length of a race may only be varied by the International Jury.

### 1.14.3

A visible countdown board will be shown at the finish line to indicate the number of remaining laps in the race.

### 1.14.4

If the Timekeeping rooms are fed by normal power (electricity) supply, they shall also be permanently connected to an U.P.S. (Uninterruptible Power System) and to a generator. **The Clerk of the Course is responsible of the proper operation.**

## 1.15 START PROCEDURE

1. Approximately 15 Minutes (10 minutes in the case of a restarted race) before the start of the race - pit lane exit opens for sighting lap.

Green Lights on at the pit lane exit.

Count-Down Boards of 5, 4, 3, 2 and 1 minute are shown at the pit exit.

Riders may complete more than one sighting lap by passing through the pit lane where they may make adjustments or refuel.

2. Approximately 10 Minutes (5 minutes in the case of a restarted race) before the start of the race - pit lane exit closes.

Red Lights on at the pit lane exit.

3. The sighting lap is not compulsory. Riders who do not take part in the sighting lap may, under the supervision of an Official, push their Sidecar on to the grid up until, at the latest 5 minutes before the start of the warm up lap.

4. Riders who do not go on to the grid may start the warm up lap from the pit lane under the instructions of the marshal positioned at the pit lane exit. Such riders may not change wheels after the display of the 3 minute board.

**Riders starting the warm up lap from the pit lane must start the race from the back of the grid.**

**The Clerk of the Course will ask the officials to check the sidecar before the rider rejoins the track.**

5. When the riders reach the grid after the sighting lap they shall take up their positions and may be attended by up to six persons, two of whom may hold an umbrella. All attendants on the grid shall wear a “Grid Pass”. Having taken up their grid position, the riders shall take off their helmets, except in the case of a restarted or wet race.

Officials will display panels, at the side of the track, indicating the row of the grid, to assist riders in locating their grid position.

6. The Clerk of the Course may, at this stage, choose to declare the race as “wet” or “dry” and will indicate this to the riders on the grid and those who may still be in the pit lane by the display of a board. If no board is displayed the race will automatically be “dry”.

7. Riders who encounter a technical problem on the sighting lap may return to the pit lane to make adjustments or to change Sidecar.

In this instance the rider shall start the warm up lap from the pit lane under the instructions of the marshal positioned at the pit lane exit.

8. Riders on the grid may, at this stage, make adjustments to the Sidecar or change tyres to suit the track conditions.
9. Refuelling or changing fuel tank on the grid is forbidden.



10. 5 Minutes Before the Start of the Warm Up Lap - Display of 5 Minute Board on the grid.
11. 3 Minutes Before the Start of the Warm Up Lap - Display of 3 Minute Board on the grid.

At this point, all persons except the one holding the umbrella, the television crew of the host broadcaster and essential officials shall leave the grid.

All adjustments must be completed by the display of the 3 Minute Board. After this board is displayed, riders who still wish to make adjustments shall push their Sidecar to the pit lane. Such riders and their Sidecars shall be clear of the grid and in the pit lane before the display of the 1 Minute Board, where they may continue to make adjustments or change Sidecar. Such riders will start the warm up lap from the pit lane. Working on the machine on the grid after the 3 Minutes Board is presented will be sanctioned by a Ride Through.

Riders shall put their helmets on.

No person (except essential officials) is allowed to go on the grid at this point.

12. 1 Minute Before the Start of the Warm Up Lap - Display of 1 Minute Board on the grid.

At this point, all persons will leave the grid.

**Any team, responsible for causing a delay in the start procedure, may be penalised.**

13. 30 Seconds Before the Start of the Warm Up Lap - Display of 30 Second Board on the grid.

All riders shall be in position on the grid with engines running. No further assistance from mechanics is permitted. Any rider who is unable to start his Sidecar shall remove it to the pit lane, under the control of the grid marshals, where he may make further attempts to start it or change Sidecar. Such riders may start the warm up lap from the pit lane.

14. 2 Minutes Before the Start of the Race - Green Flag waved to start the warm up lap.

In the interest of safety, should a rider stall his Sidecar, he may be assisted to restart. If, after a reasonable period, the engine does not start, then the rider will be pushed into the pit lane where his mechanics may provide assistance or where the rider may change Sidecar.

The riders will make one lap, at unrestricted speed, followed by a Safety Car. The Safety Car will overtake slow riders.

**Any rider who arrives at pit lane entry after safety car must enter the pit lane and start the race from there.**

As soon as the riders have passed the pit lane exit, the pit lane exit light will be turned green, and any rider waiting in the pit lane will be permitted to join the warm up lap. Thirty seconds later, the light will turn red closing the pit lane exit.

On returning to the grid the riders shall take up their positions with the front wheel of their Sidecar up to and behind the front line and between the side lines defining the grid position and keep their engines running. **The front tyre must not be touching the track surface outside of the painted lines.**

An Official will stand at the front of the grid holding a Red Flag presented motionless.

Any rider who stalls his engine on the grid or who has other difficulties shall remain on the Sidecar and raise an arm. It is not permitted to attempt to delay the start by any other means.

As each row of the grid is completed, the Officials will lower the panels indicating that their row is complete. Panels will not be lowered when a rider in that row has indicated that he has stalled his Sidecar or has other difficulties. When all panels have been lowered and the Safety Car has taken up its position, an Official at the rear of the grid will wave a Green Flag.

The Starter will then instruct the Official at the front of the grid, displaying the Red Flag, to walk to the side of the track.

15. A Red Light will be displayed for between 2 and 5 seconds. The Red Light will go out to start the race.

A Safety Car will follow behind the Sidecars for the whole of the first lap. The Safety Car will overtake slow riders.

If the Red Lights' device is fed by normal power (electricity) supply, it shall also be connected to a set of car batteries or to an U.P.S. (Uninterruptible Power System) to provide power to the starting lights' device if the electric line breaks down just at the moment of the start.

Any rider who anticipates the start will be required to carry out the Ride through procedure described under article 1.16.

The Sidecar must be stationary at the time the Red Lights are turned off. Anticipation of the start is defined by the Sidecar moving forward at the time the Red Lights are turned off. In the case of a minor movement and subsequent stop whilst the Red Lights are on, **the Clerk of the Course** will be the sole judge of whether an advantage has been gained.

The International Jury will decide if a penalty will be imposed for taking advantage by anticipating the start and must communicate the penalty to the rider **as soon as possible**.

16. If, after the start of the race, a rider stalls his Sidecar, then he may be assisted by being pushed along the track until the engine starts.

If, after a reasonable period, the engine does not start, then the rider will be pushed into the pit lane where his mechanics may provide assistance or where the rider may change Sidecar.

17. After the riders have passed the exit of the pit lane, the Official situated at this exit will display a Green **Light/Flag** to start any riders still in the pit lane. The Clerk of the Course may apply a delay before the display of the Green **Light/Flag** according to the layout and distance of the pit exit. In that case an **Official information** will be circulated.
18. Unless the race is interrupted, after the leading rider has passed the finish line at the end of his first lap, no further changes of Sidecars are permitted.

19. Should there be a problem that might prejudice safety at the start, then the Starter will invoke the Start Delayed procedure as follows:

- A Red Flag is waved from the Starter's rostrum and the Red Light stays on.
- The "Start Delayed" board is displayed from the Starter's rostrum and a marshal will wave a Yellow Flag at each row of the starting grid from the signalling platform.
- Riders must stay in their grid position with helmets on, engines may be switched off.
- The machine(s) which caused the Start Delayed procedure will be removed to the pit lane, regardless of what work is needed to restart the machine. If they can be restarted or a spare machine is taken the rider may start the warm up lap from pit lane, and will start the race from the back of the grid.
- After display of the Start Delayed Board, a maximum of 2 mechanics per rider are allowed on the grid. Only hand-carried tools are allowed.
- Only essential Officials are allowed on the grid, no media, guests, umbrella-holders or other team personnel will be permitted, with the exception of camera crew(s) authorised by the Organisers.
- The start procedure will be re-commenced at the 3 Minute Board, which the Starter will order to be displayed as soon as possible (normally as soon as all riders on the grid are attended by their team).
- Following the 1 Minute and 30 Second Boards the riders will complete an additional warm up lap. The race distance will be reduced by one lap.

Any person who, due to his behaviour on the grid is responsible for a "Start Delayed" may be further penalised.

### 1.15.1 Quick Restart procedure

When a race is stopped, riders must return to the pit lane, unless otherwise instructed by Officials. If there is to be a second part to the race, minor repairs may be carried out. The following procedure will take place:

- 1) Upon arrival in the pit lane, riders may make adjustments to their Sidecar. Refuelling is permitted in the pit lane even for teams with no garages (Prior to the start of the race, teams should ensure that all necessary equipment is located in the pit lane service area in a safe position).
- 2) When all riders have entered the pit lane the Clerk of the Course will announce the time remaining to the re-opening of the pit lane.
  - a) The duration between the Red Flag and the actual opening of the pit exit will be 10 minutes or more.
  - b) The time remaining to the opening of the pit exit will be displayed on timing screens and in the starting grid countdown clock.
- 3) When the time period has elapsed, the pit lane exit will be opened for SIXTY SECONDS only. Riders will make one lap at unrestricted speed to the starting grid, followed by a Safety Car. Any rider delaying the progress of the sighting lap will be overtaken by the Safety Car. Any rider arriving behind the Safety Car must go into the pit lane. Such riders will have to start the warm up lap from the pit lane and will start the race from the back of the grid.
- 4) Any riders remaining in the pit lane after it has been closed will have to start the warm up lap from the pit exit and start the race from the back of the grid.
- 5) ONE mechanic only, per rider, may go onto the grid (without tools) to primarily indicate to his rider his position on the grid. In the case of a race impacting new grid positions, the mechanic should avail himself of his riders' new grid position from the classification displayed on the timing screen or from Officials who will be positioned at the entry point to the grid with the revised starting grid information.



- 6) All riders will arrive back on the starting grid, and stop, with engines running, no adjustments may be made. Any rider encountering difficulties on the “out lap” from the pit exit must enter the pit lane.
- 7) As soon as the Safety Car arrives on the back of the grid, a 30 Seconds Board will be shown. At this point the mechanics must immediately leave the grid by the quickest route. The 30 seconds may be reduced at the discretion of the Clerk of the Course when the grid is cleared and it is considered safe.
- 8) After 30 seconds have elapsed a Green Flag will be shown to start the warm up lap.
- 9) The warm up lap will be completed at unrestricted speed, followed by a Safety Car. When the last rider has passed the pit exit it will be opened for a period of 30 seconds to release any rider waiting. The pit lane exit will remain closed until after the start of the race. Any rider delaying the progress of the warm up lap will be overtaken by the Safety Car.
- 10) Any rider not able to leave the pit exit has a final option of starting the race from the pit exit.
- 11) Upon arrival back at the starting grid the normal start procedure will be followed, with the start signal given in the normal manner.
- 12) Riders who started the warm up lap from the pit lane must start the race from the back of the grid as directed by Officials. If two or more riders must start from the back of the grid, they will take up position in the order in which they qualified for the race or, in case of a restarted race, according to the position they qualified in the previous Red Flagged race.  
**Any rider who arrives at pit lane entry after safety car must enter the pit lane and start the race from there.**
- 13) After the start signal has been given and the last rider has passed the pit exit, the pit exit will be opened. Any riders still in the pit lane may then start the race at any time.
- 14) **The race distance will be according to Art. 1.22.**

## 1.16 RIDE THROUGH PROCEDURE

During the race, the rider will be requested to ride through the pit lane. Stopping is not permitted.

He may then rejoin the race.

The rider **must** respect the speed limit (Art. 1.18.14) in the pit lane. In case of infraction of this speed limit, the Ride Through procedure will be repeated; in case of a second infraction of this speed limit, the Black Flag will be shown to the rider.

In the event of a restarted race, the above regulation will also apply.

In the case of a race interrupted prior to the penalty being complied with, and if there is a second part, the rider will be required to ride through after the start of the second part of the race.

In the case of a rider carrying forward a penalty for anticipation of the start, into the second part of an interrupted race and subsequently found to have anticipated the second start, the rider will be shown the Black Flag.

A yellow board (100 cm horizontal x 80 cm vertical) displaying the rider's number (black colour, height 50 cm, stroke width 10 cm) will be shown at the finish line and the information will also be displayed on the time keeping monitors.

Failure by the relevant rider to ride through, having been shown the board 5 times, will result in that rider being shown the Black Flag.

If more than one rider is penalised, the riders will be signalled to ride through on subsequent laps. The order of the riders will be based on the qualifying times with the faster rider first.

In the case of a rider failing to respond to the instruction to ride through, and there being more than one rider penalised, no subsequent riders will be signalled to ride through until the previous rider has completed the ride through procedure or has been shown the Black Flag.

In the case where the organisation has been unable to carry out the ride through penalty before the end of the race, the relevant rider will be inflicted with an **automatic** time penalty.

**This automatic time penalty cannot be subject of any protest or appeal.**

## **1.17 “WET” AND “DRY” RACES**

### **1.17.1**

All races will be categorised as either wet or dry. A board may be displayed on the grid to indicate the status of the race. If no board is displayed, the race is automatically dry. The purpose of this classification is to indicate to riders the consequence of varying climatic conditions during a race.

### **1.17.2**

Dry Races - a race classified as dry will be interrupted by the Clerk of the Course, if he considers that climatic conditions affecting the surface of the track makes it likely that riders will wish to change tyres.

### **1.17.3**

Wet Races - a race classified as wet, usually commenced in varying or wet conditions, will not be stopped for climatic reasons and riders who wish to change tyres or make adjustments shall enter the pits and do so during the actual race.

### **1.17.4**

In all cases where the first race is stopped for climatic reasons, then the restart will, automatically, be a “wet” race.

## **1.18 BEHAVIOUR DURING PRACTICE AND RACE**

1. Riders shall obey the flag signals, the light signals, the **Officials’ instructions** and the boards which convey instructions.

Any infringement to this rule will be penalised according to the provisions of article 1.19.

2. Riders must ride in a responsible manner which does not cause danger to other competitors or participants, either on the track or in the pit-lane. Any infringement of this rule may be penalised.
3. Riders should use only the track and the pit-lane. However, if a rider accidentally leaves the track then he may re-join it at the place indicated by the officials or at a place which does not provide an advantage to him.

Any infringement of this rule during the practices or warm up will be penalised by the cancellation of the lap time concerned and during the race, by a penalty decided by the Clerk of the Course.

If a drop of position penalty is imposed, the penalty will be first communicated on the timekeeping screens and then a board will be displayed for the rider on the finish line during a maximum of 5 laps. If the rider did not go back after the board has been presented 5 times, he will be penalised by a Ride Through.

Further penalties may also be imposed.

4. Any repairs or adjustments along the race track shall be made by the rider working alone with absolutely no outside assistance. The marshals may assist the rider to the extent of helping him to lift the Sidecar and holding it whilst any repairs or adjustments are made. The marshal may then assist him to re-start the Sidecar.
5. If the rider intends to retire, then he shall park his Sidecar in a safe area as indicated by the marshals.
6. If the rider encounters a problem with the Sidecar which will result in his retirement from the practice or the race, then he should not attempt to tour at reduced speed to the pits but should pull off the track and park his Sidecar in a safe place as indicated by the marshals.
7. Riders who are returning slowly to the pits for remedial work should ensure that they travel as far as possible off the racing line.



8. Riders may enter the pits during the race. Refuelling and changing Sidecar are strictly prohibited.
9. Riders who stop their engines in the pits may be assisted to re-start their Sidecar by the mechanics.
10. Riders are not allowed to transport another person on their Sidecar or to be transported by another rider on his Sidecar (exception: Another rider or by another rider after the Chequered Flag or the Red Flag).
11. Riders shall not ride or push their Sidecars in the opposite direction of the circuit, either on the track or in the pit lane, unless doing so under the direction of an Official.
12. No signal of any kind may pass between a moving Sidecar and the rider's team, or anyone connected with the Sidecar's team entrant or rider, except for the signals of the timekeeping transponder, lap trigger, GPS, legible messages on a pit board, or body movements by the rider or team.

On board TV camera signals are allowed, but only when such signals are for the purposes of and managed by the FIM or the Championship local Organiser.

13. Riders in the top ten positions may be required to carry up to two “on-bike” cameras on their Sidecar.

The cameras and associated equipment shall be carried during all practice sessions and the race.

Cameras and other equipment will be supplied to the designated teams by, at the latest, two hours before the first practice at an event.

Teams shall give reasonable access and assistance to the company designated for the supply of the camera equipment to facilitate the mounting of the equipment.

On-board-cameras (other than the FIM Championship promoters' cameras or those allowed by the FIM Administration) are not permitted.

If a team wishes to install its own on-board-camera, it has to make an official request to the TV Department of the FIM Administration.

The installation of the on-board-cameras on Sidecars has to be carried out in conformity with the Art. 2.4.

14. A speed limit of 60 km/h will be enforced in the pit lane at all times during the event. Riders shall respect the speed limit from where the sign 60 km/h is placed up to where the sign 60 km/h crossed out is placed.

Any rider found to have exceeded the pit lane speed limit during the practice will be subject to a fine of 150 €.

Any rider who exceeds the pit lane speed limit during a race will be penalised with a Ride Through.

The International Jury shall communicate the offence to the pit of the rider after having received the information from the Official in charge.

15. Stopping on the track during practices and races is forbidden.
16. During the practice sessions and warm ups, practice starts are permitted, when it is safe to do so, at the pit lane exit before joining the track and after passing the Chequered Flag at the end of practice sessions and warm ups, when it is safe to do so, off the racing line.
17. If the winning rider wishes to parade a flag, he shall ride to the side of the racing surface to collect the flag and then rejoin the circuit when it is safe to do so.
18. After the Chequered Flag, riders riding on the track must wear a safety helmet until they stop on the pit lane/Parc Fermé.
19. It is not permitted to ride racing Sidecars within the circuit other than in the pit lane or on the track.

20. Any rider or team whose Sidecar spill oil on the track causing interruption of practice, warm up or race twice in the same event may be penalised.
21. Any rider who enters **twice** the pit lane during the race, to make adjustments (for other reasons than changing tyre), **will** be forbidden by the Clerk of the Course to re-join the race.
22. The pit lane exit road will be defined by the Clerk of the Course and marked with painted lines. A dotted white line (interrupted line) will signify the end of the pit lane road, which is the point where the track starts and racing may commence. Riders must stay inside the painted lines defining the pit exit road until passing the dotted white line, during all track sessions (practice and race).

Infractions may be penalised with an instant penalty.

23. Riders must wear the FIM logo.

## **1.19 FLAGS AND LIGHTS**

Marshals and other Officials display flags or lights to provide information and/or convey instructions to the riders.

All flags are presented waved.

### **1.19.1 Flags and lights used to provide information:**

- **Green Flag**

The track is clear.

This flag shall be shown waved at each flag marshal post for the first lap of each practice session and of the warm up, for the sighting lap and for the warm up lap.

This flag shall be shown waved at the flag marshal post immediately after the incident that necessitated the use of one or more Yellow Flags.

This flag shall be waved by the starter to signal the start of the warm up lap.

This flag may be waved at pit exit, in conjunction with the official signal of the green light, as an extra signal that pit lane exit is open.

- **Yellow and Red Striped Flag**

The adhesion on this section of the track could be affected by any reason other than rain.

This flag shall be shown waved at the flag marshal post.

- **White Flag with Diagonal Red Cross**

Drops of rain on this section of the track.

This flag shall be shown waved at the flag marshal post.

- **White Flag with Diagonal Red Cross + Yellow and Red Striped Flag**

Rain on this section of the track.

These flags shall be shown together waved at the flag marshal post.

- **Blue Flag**

Shown waved at the flag marshal post, this flag indicates to a rider that he is about to be overtaken.

During the practice sessions, the rider concerned shall keep his line and slow down gradually to allow the faster rider to pass him.

During the race, the rider concerned is about to be lapped. He must allow the rider(s) who are lapping him to pass him at the earliest opportunity and passing within a group of lapped riders is forbidden under the Blue Flag.

**Waved at a Marshall post after the pit lane exit, this flag indicates to a rider exiting the pit lane that riders are approaching on track. The rider exiting pit lane must do so safely and without disturbing riders on track.**

Any infringement of this rule may be penalised.

- **Chequered Black/White Flag**

This (these) flag(s) will be waved at the finish line to indicate the finish of race or practice session.

After having received the Chequered Flag, riders must return slowly to the pits. They cannot stop on the track right after the finish line.

- **Chequered Black / White Flag and Blue Flag**

The Chequered Black/White Flag(s) will be waved together with the Blue Flag waved at the finish line when a rider(s) precedes closely the leader during the final lap before the finish line (see Art. 1.21.1).

- **Green Light**

This light must be switched on at the pit lane exit to signal the start of each practice session and of the warm up, the start of the sighting lap and the start of the warm up lap.

- **Flashing Blue Lights**

Will be switched-on at the pit lane exit at all time during practices and races.

### 1.19.2 **Flags which convey information and instructions:**

- **Yellow Flag**

Waved at each row of the starting grid, this flag indicates that the start of the race is delayed.

A single Yellow Flag waved at the flag marshal post, this flag indicates that there is a danger ahead beside the track.

Two Yellow Flags waved together at the flag marshal post indicate that there is a hazard wholly or partly blocking the track.

**The waving of a single or of a double yellow flag does not signify a degree of danger but only the location of the incident.**

The riders must slow down and be prepared to stop. Overtaking is forbidden up until the point where the Green Flag is waved.

Any infringement of this rule during a practice session will result in the cancellation of the time of the lap during which the infraction occurred.

In case of infringement of this rule during the race, the rider must go back the number of positions decided by the Race Director. A board will be displayed for the rider on the finish line during a maximum of 5 laps. If the rider did not go back after the board has been presented 5 times, he will be penalized by a Ride Through.

In both cases, further penalties may also be imposed.

If, immediately after having overtaken, the rider realises that he committed an infraction, he must raise his hand and let pass the rider(s) that he has overtaken. In this case, no penalty will be imposed.

During the final inspection lap, this flag shall be waved at the exact place where the flag marshal will be positioned during the practices, the warm ups and races.

- **Red Flag and Red Lights**

When the race or practice is being interrupted, the Red Flag will be waved at each flag marshal post and the Red Lights around the track will be switched on. Riders shall return slowly to the pits.

When the pit-lane exit is closed, the light will be switched on **and the red flag may be used in conjunction with the official red light signal.** Riders are not allowed to exit the pit lane.

Any infringement of this rule may be penalised.

The Red Flag will be shown motionless on the starting grid at the end of the warm up lap.

The Red Flag may also be used to close the track.

The Red Lights will be switched on at the start line for between 2 and 5 seconds to start each race.

- **Black Flag**

This flag is used to convey instructions to one rider only and is waved at each flag marshal post together with the rider's number.

The rider shall stop at the pits at the end of the current lap and cannot restart when this flag results from a penalty.

This flag can also be presented to a rider for a reason other than a penalty (i.e. for checking or changing a transponder).

Any infringement of this rule may be penalised.

- **Black Flag with Orange Disk (Ø 40 cm)**

This flag is used to convey instructions to one rider only and is waved at each flag marshal post together with the rider's number.

This flag informs the rider that his Sidecar has mechanical problems likely to endanger himself or others, and that he shall immediately leave the track.

Any infringement of this rule may be penalised.

### 1.19.3 Flag Dimension

The flag dimension should be 80 cm in the vertical and 100 cm in the horizontal.

The flag dimension will be checked the day before the day of the first practice session.

### 1.19.4 Flag Colour

The Pantones for the colours are as follows:

Orange:	Pantone 151 C
Black:	Pantone Black C
Blue:	Pantone 298 C
Red:	Pantone 186 C
Yellow:	Pantone Yellow C
Green:	Pantone 348 C

The flags' colours will be checked the day before the day of the first practice session.

### **1.19.5 Rider's Number Board**

Black board (70 cm horizontal x 50 cm vertical) which enables the race number of a rider to be attached with a set of numbers in white, whose stroke width is minimum 4 cm and height minimum 30 cm.

This board must be available at each flag marshal post.

### **1.19.6 Flags Marshals posts**

The location will be fixed during the Circuit Homologation.

### **1.19.7 Marshals Uniforms**

It is strongly recommended the marshals' uniforms to be in white or orange (Ref. Pantone: 151 C) and the rain coat to be transparent.

## **1.20 MEDICAL CARS**

The Medical Cars, if they are to go on to the track, shall be equipped with yellow flashing lights. The words "MEDICAL CAR" should be clearly indicated on the back and the sides of the car.

## **1.21 FINISH OF A RACE AND RACE RESULTS**

### **1.21.1**

When the leading rider has completed the designated number of laps for the race, he will be shown a Chequered Flag waved by an Official located at the finish line behind 1st protection line. The Chequered Flag will continue to be waved to the subsequent riders.

When the Chequered Flag is waved to the leading rider, no other rider will be permitted to enter the track from the pit lane.

As soon as the Chequered Flag is waved to the leading rider, the Red Light will be switched on at the pit lane exit and a marshal showing a Red Flag will stand in the pit lane exit.

If a rider(s) closely precedes the leader during the final lap before the finish line, the official will show to the rider(s) and to the leader simultaneously the Chequered Flag and the Blue Flag. That means that the race is finished for the leader while the rider(s) closely preceding the leader has (have) to complete the final lap and take the Chequered Flag.

### 1.21.2

In case of a photo-finish between two, or more, riders, the decision shall be taken in favour of the competitor whose Sidecar leading edge crosses the plane of the finish line first. In case of ties, the riders concerned will be ranked in the order of the best lap time made during the race.

### 1.21.3

The results will be based on the order in which the riders cross the line and the number of laps completed.

### 1.21.4

To be counted as a finisher in the race and be included in the results a rider shall:

- a) Complete 75% of the race distance.
- b) Cross the finish line on the race track (not in the pit lane) within five minutes of the race winner. The rider shall be in contact with his Sidecar.

### 1.21.5

The classification including the FIM and FMNR logos, will mention, at least, the following information:

- The names of the riders and passengers;
- The performance carried out (laps, time);

It is compulsory for the Jury President to send a list of fines and results by fax or email immediately after the approval of results to the FIM Administration.

## 1.22 INTERRUPTION OF A RACE

### 1.22.1

If the Clerk of the Course decides to interrupt a race due to climatic conditions or some other reason, then Red Flags will be waved at the finish line and at all flag marshals' posts and he will switch on the Red Lights around the circuit. Riders must immediately slow down and return to the pit lane.

At the time the Red Flag is waved, riders who are not actively competing in the race will not be classified.

Within 5 minutes after the Red Flag has been waved, riders who have not entered the pit lane, pushing or riding on their Sidecar, will not be classified.

The results will be the results taken at the last point where the leader and all other riders on the same lap as the leader had completed a full lap without the Red Flag being displayed calculated as in the principle set out in the following example:

Example of a race consisting of 30 laps:

If a Red Flag is waved when the leader is on his 10<sup>th</sup> lap after completing his 9<sup>th</sup> lap and all other Sidecars have not completed the 9<sup>th</sup> lap, then the race result will be 8 laps completed, and the second part will consist of 22 laps.

If a Red Flag is waved when the leader and all other Sidecars on the same lap as the leader are on the 10<sup>th</sup> lap after completing the 9<sup>th</sup> lap, the race result will be 9 laps completed and the second part will consist of 21 laps.

#### Exception:

If the race is interrupted after the Chequered Flag, the following procedure will apply:

1. For all the riders to whom the Chequered Flag was waved before the interruption, a partial classification will be established at the end of the last lap of the race.
2. For all the riders to whom the Chequered Flag was not waved before the interruption, a partial classification will be established at the end of the penultimate lap of the race.

3. The complete classification will be established by combining both partial classifications as per the principle of the lap/time.

### 1.22.2

If the results calculated show that less than three laps have been completed by the leader of the race and by all other riders on the same lap as the leader, then the race will be null and void and a completely new race will be run. If it is found impossible to re-start the race, then it will be declared cancelled and the race will not count for the Championship.

### 1.22.3

If three laps or more have been completed by the leader of the race and all other riders on the same lap as the leader, but less than two-thirds of the original race distance, rounded down to the nearest whole number of laps, then the race will be re-started according to article 1.23.4. If it is found impossible to re-start the race, then the results will count and only half points will be awarded for the Championship.

### 1.22.4

If the results calculated show that two-thirds of the original race distance rounded down to the nearest whole number of laps have been completed by the leader of the race and by all other riders on the same lap as the leader, then the race may be deemed to have been completed and full points will be awarded for the Championship or the race may be restarted.

## 1.23 RE-STARTING A RACE THAT HAS BEEN INTERRUPTED

### 1.23.1

If a race has to be re-started, then it will be done as quickly as possible, consistent with track conditions allowing. As soon as the riders have returned to the pits, the Clerk of the Course will announce a time for the new start procedure to begin and the start procedure type (Normal Start or Quick Start) for the new start procedure to begin which, conditions permitting should not be later than 20 minutes after the initial display of the Red Flag.

### 1.23.2

The intermediary placings shall be available to the teams before the following part of a race may be started.

### 1.23.3

The start procedure will be identical to a normal start with a sighting lap, warm up lap, etc.

### 1.23.4

Conditions for the re-started race will be as follows:

- i) In the case of a situation as described in 1.22.2 above (less than 3 laps completed):
  - a) All riders may re-start.
  - b) Sidecars may be repaired or changed.  
Refuelling is permitted.
  - c) The number of laps will be the same as the original race distance.
  - d) The grid positions will be as for the original race.
- ii) In the case of a situation as described in 1.22.3 (3 laps or more and less than two-thirds completed) above:
  - a) Only riders who are on the intermediary placings may re-start.
  - b) Sidecars may be repaired or changed.  
Refuelling is permitted.
  - c) The number of laps of the second race will be the number of laps required to complete the original race distance.
  - d) The grid position will be based on the order of the intermediary placing.
  - e) The final result of the race will be based on the results of each rider classified in each race added together.

Riders who have completed an identical number of laps will be placed according to the combined time.

### 1.23.5

Any start position penalties applying to a rider in the first race. e.g. a drop of grid position or starting the race from pit lane, if such penalties were duly applied at the original race start and will not apply to the restarted race.

In the case of Art. 1.23.4 (race interrupted with less than 3 laps completed), the new start will be a completely new race so therefore existing start position penalties will apply.

## 1.24 CHECK AREA/PARC FERMÉ

At the end of the race, or the final part of a race that has been interrupted, all the classified Sidecars will be directed to a compulsory check area (Parc Fermé) pending inspection by the Technical Stewards or potential protests.

It is the responsibility of the teams and riders to ensure that the Sidecar is in the Parc Fermé. Sidecars will normally be released from the Parc Fermé 30 minutes after the finish of the race. They cannot be removed without the approval of the Jury.

With the exception of Jury members, the Clerk of the Course and officials who are in charge of keeping watch over the closed park area, no-one may at any time or for any reason be admitted into this area unless they have a written and signed authorisation from the Clerk of the Course.

## 1.25 PODIUM

The riders placed in the first three positions in the race will be escorted by Officials, as quickly as possible, to the podium for the Awards Ceremony.

Participation in the podium ceremony by the first three riders is compulsory.

## **1.26 FINAL TECHNICAL CONTROL**

At the end of each race, a Technical Control with dismantling may be carried out on the first 3 Sidecars and other Sidecars chosen by random by the President of the International Jury and the FIM Technical Director.

## **1.27 EXTRA DEPOSITS IN CASE OF SIDECAR CONTROL FOLLOWING A PROTEST**

The deposit in case of dismantling and reassembling a Sidecar to measure the cylinder capacity, following a protest, is 150 € (material included).

The deposit in case of partial or complete dismantling of an engine or gearbox is 300 €.

If the party who makes the protest is the losing party, the deposit shall be paid to the winning party. If the party who makes the protest is the winning party, the deposit shall be reimbursed.

## **1.28 DEPOSIT FOR FUEL CONTROLS FOLLOWING A PROTEST**

All requests for fuel control following a protests or an appeal must be accompanied by a deposit of 660 €, paid to the FIM.

After the last control:

- the winning party will have its deposit reimbursed.
- the losing party will have to pay the costs of all the controls carried out after deduction of deposits which it has already paid.

## 1.29 SANCTION FOR NON-COMPLIANCE WITH THE FUEL RULES

A fuel control may be carried out in accordance with Art. 2.10.5 of the Sidecar Technical Regulations. A rider whose fuel does not correspond to the technical requirements will be sanctioned as follows:

1. Exclusion from the whole event in question independent of the moment of the fuel sampling
2. Fine of 500 €
3. Payment of all costs connected to the fuel test(s) for his case

## 1.30 CHAMPIONSHIP POINTS AND CLASSIFICATION

### 1.30.1

Riders will compete for the FIM Sidecar World Championship.

### 1.30.2

For riders, the points will be those gained in each race.

### 1.30.3

For each race, points will be awarded on the following scale:

1 <sup>st</sup>	25 points
2 <sup>nd</sup>	20 points
3 <sup>rd</sup>	16 points
4 <sup>th</sup>	13 points
5 <sup>th</sup>	11 points
6 <sup>th</sup>	10 points
7 <sup>th</sup>	9 points
8 <sup>th</sup>	8 points
9 <sup>th</sup>	7 points
10 <sup>th</sup>	6 points
11 <sup>th</sup>	5 points
12 <sup>th</sup>	4 points
13 <sup>th</sup>	3 points
14 <sup>th</sup>	2 points
15 <sup>th</sup>	1 point

### 1.30.4

All races will count for the **Championship classification**.

### 1.30.5

In the event of a tie in the number of points, the final positions will be decided on the basis of the number of best results in the races (number of first places, number of second places etc.). In the event that there is still a tie then, the date in the Championships at which the highest place was achieved will be taken into account with precedence going to the latest result.

### 1.30.6

In a case where a rider changes his passenger during the season, it is the name of the passenger with whom he has obtained the largest number of points that will appear in the final classification. In case of a tie with another passenger, the name of the one who has raced the most rounds will appear in the final classification.

### 1.30.7

In the case where a rider participates on different Sidecars, it is the make of the Sidecar with which he obtained the most points that will appear next to his name in the final classification, without, however, modifying the calculation for the constructors' classification.

### 1.30.8

The World Champions are obliged to attend an official FIM ceremony.

## 1.31 PRIZE-GIVING CEREMONY

A Prize-Giving ceremony for the first three winners of **each** race is recommended. This ceremony must be held immediately after the race in question, if conditions and time permitting.

The following persons must take part in the Prize-Giving ceremony of the **Championship**:

- a) The rider and passenger winning the event
- b) The second placed rider and passenger in the event
- c) The third placed rider and passenger in the event

Furthermore, during the last round of the **Championship**, the first three riders and passengers in the final results of the **Championship** must take part in the official Prize-Giving ceremony, which must be held immediately after the last race podium ceremony, conditions and time permitting.

Any infraction of this rule may be penalised by the International Jury.

During the official Prize-Giving ceremonies, the national anthem of the winner's rider country (based on the passport of the driver) must be played and the national flags of the first three drivers may be hoisted at the same time.

## **1.32 INSTRUCTIONS AND COMMUNICATIONS TO COMPETITORS**

### **1.32.1**

Instructions may be given by the International Jury and/or Clerk of the Course to teams and/or riders by means of special circulars in accordance with the Regulations. Circulars must be posted on the official notice board. Posting on the official notice board will be deemed as proof of delivery.

### **1.32.2**

All classifications and results of practice and the race, as well as all decisions issued by the Officials, must be posted on the official notice board. Posting on the official notice board will be deemed as proof of delivery and official publication.

### **1.32.3**

Any communication from the International Jury or the Clerk of the Course to a team or rider shall be communicated in writing. Similarly, any communication from a team or rider to the International Jury or the Clerk of the Course shall also be made in writing.



**SUPPLEMENTARY REGULATIONS  
(Suggestion for Organisers)**

**1. ANNOUNCEMENT**

The \_\_\_\_\_ on behalf of \_\_\_\_\_ will organise the \_\_\_\_\_ at the circuit \_\_\_\_\_.

This meeting will be held on \_\_\_\_\_ and will count towards the \_\_\_\_\_ FIM Sidecar World Championship IMN: \_\_\_\_\_

**2. THE SECRETARIAT OF THE ORGANISING COMMITTEE**

Address of the organising committee: \_\_\_\_\_

Before the: \_\_\_\_\_

After the: \_\_\_\_\_

During the meeting: \_\_\_\_\_

**3. CIRCUIT**

The length of the circuit is \_\_\_\_\_ km.

The race will be run clockwise/anti-clockwise.

A drawing of the circuit is enclosed.

**4. JURISDICTION**

The meeting will be held in accordance with the FIM Sporting Code, the CCR rules and these Supplementary Regulations.

The Organiser also commits to respect as much as possible the “Green line” charter of good practice.

**5. OFFICIALS**

- Jury President: \_\_\_\_\_

- Jury members: \_\_\_\_\_

- FMNR Delegate: \_\_\_\_\_

- Head of organisation: \_\_\_\_\_

- Clerk of the Course: \_\_\_\_\_



- Secretary of the meeting: \_\_\_\_\_
- FIM Technical Director: \_\_\_\_\_
- Chief Technical Steward: \_\_\_\_\_
- Chief timekeeper: \_\_\_\_\_
- Chief Medical Officer: \_\_\_\_\_
- Environmental Steward: \_\_\_\_\_

Address of Jury members during the meeting:

## 6. NUMBER OF SIDECARS ALLOWED

Practice:

Qualified for the race:

## 7. ENTRIES, DEPOSIT

Applications for entry shall be made on the official forms included with these regulations.

Applications shall be approved by the rider's FMN and shall reach the organisers not later than \_\_\_\_\_ midnight.

The organiser will select the applications and advise teams within 72 hours after the closing date of entries whether their applications have been accepted or rejected.

**The entry fee is the one mentioned in the Rules.**

The maximum deposit amount for transponders is \_\_\_\_\_ .

## 8. TECHNICAL INSPECTION

No rider or Sidecar is permitted onto the track unless he/it has passed the technical inspections which will be held according to the following schedule:

**Date & Time:**

From \_\_\_\_\_ to \_\_\_\_\_

## 9. PRACTISING

It is strictly forbidden to ride racing Sidecars on the course outside the official practice periods.



Schedule according to Art. 1.9.

The practices sessions will be held as follow:

Date & Time: Free practice(s) from \_\_\_\_\_ to \_\_\_\_\_

Date & Time: Qualifying practices from \_\_\_\_\_ to \_\_\_\_\_

## 10. RACES: SCHEDULE

Schedule according to Art. 1.9.

Date & Time:

from \_\_\_\_\_ to \_\_\_\_\_

Distance: \_\_\_\_\_ laps & \_\_\_\_\_ km

## 11. PRIZE-GIVING

Place - date

## 12. PROTESTS

All protests shall be made in accordance with the requirements of the FIM Disciplinary and Arbitration Code and be accompanied by a fee of \_\_\_\_\_ (local currency - amount equivalent to 660 €).

## 13. FUEL

If fuel is supplied by the organisers at the fuel-station, it will be in conformity with Article 2.10 of the Sidecar World Championship Regulations.

## 14. INSURANCE

By endorsing the application form for entry the FMN of the rider certifies that the rider is insured in accordance with the FIM requirements.

In conformity with Article 110.1 of the Sporting Code, third party insurance in respect of riders covering accidents occurring during the meeting including practices will be the responsibility of the organiser.

This insurance includes a guarantee of \_\_\_\_\_.

The organiser disclaims all responsibility for damage to a Sidecar, its accessories and components arising out of an accident, fire or other cases.

## **15. RENUNCIATION OF ANY RECOURSE AGAINST SPORTING AUTHORITIES**

Apart from the requirements of the FIM Sporting Code, riders and teams by participating renounce all rights of appeal against the organiser, his representatives or agents by arbitration or before a tribunal or any other manner not foreseen by the FIM Sporting Code for any damages for which they could be liable in consequence of all acts or omissions on the part of the organiser, his officials, representatives or agents in the application of these regulations or contributed to or arising out of their actions.

## **16. RIDER'S EQUIPMENT**

An on-board-camera (other than the one from the FIM TV Crew or permitted by the FIM Administration) is not allowed during the entire event, from the practice sessions until the end of the event.

If riders wish to place their own on-board camera, they must contact the TV Department of the FIM Administration, for approval.

## **17. ENVIRONMENTAL MAT**

As per article 4.1 of the FIM Environmental Code regarding the protection of the floor, Superside teams must accomplish the usage of an standardized environmental mat.

The Environmental Mat must be composed of an absorbent upper part and an impermeable lower part. The use of an environmental mat protecting the ground (or other effective system for events taking place at circuits with permanent facilities) to prevent soil and water contamination is compulsory:

- a) Wherever work on motorcycles is allowed by the organisers;
- b) Under all waste oil and fuel containers provided by the organisers;
- c) At all official refuelling points;
- d) Under all thermic powered generators and power washers.



The minimum technical data for the mat are:

- Dimensions: Minimum 160 cm x 100 cm

Any infraction of this rule will be reported to the International Jury who will fine the rider responsible a maximum of EUR 370.- or any other amount mentioned in the regulation or appendix of the discipline. Other sanctions can be pronounced by the International Jury in accordance with the competences mentioned in Article 3.1.3 of the Disciplinary and Arbitration Code (DAC) and Article 50.1.3 of the Sporting Code.

## 18. CODE OF ETHICS

All persons participating or involved in any capacity in an FIM Sports event or FIM activity, or acting on behalf of the FIM commits themselves to respect and apply the FIM Ethical Code.

Enclosures:

- drawing of the circuit
- entry form

Place and date: \_\_\_\_\_

The President of the Organising Committee: \_\_\_\_\_

The Clerk of the Course: \_\_\_\_\_

The Secretary of the Meeting: \_\_\_\_\_

Approved on: (FMNR) \_\_\_\_\_

Approved on: (FIM/CCR) \_\_\_\_\_



Meeting: \_\_\_\_\_ IMN: \_\_\_\_\_

**Jury meeting No. 1**

The first Jury meeting will take place 1 1/2 hours before the beginning of the free practice (in accordance with the SR of the event).

Venue: \_\_\_\_\_ Date: \_\_\_\_\_ Time: \_\_\_\_\_

End: \_\_\_\_\_

**1. Presence:**

**1.1 Members of the Jury with voting rights**

President: \_\_\_\_\_

Member: \_\_\_\_\_

FMNR Delegate: \_\_\_\_\_

**1.2 Members of the Jury without voting rights, designated by the FIM**

FIM Technical Director: \_\_\_\_\_

Medical delegate: \_\_\_\_\_

**1.3 Clerk of the Course**

\_\_\_\_\_

**1.4 FMN delegates**

\_\_\_\_\_

**1.5 Environmental Steward**

\_\_\_\_\_

**1.6 Others**

\_\_\_\_\_



## **2. Supplementary Regulations**

- third party insurance policy
- possible alterations
- additions

## **3. Approval of the entry list**

## **4. Condition of the track**

## **5. Condition of services**

Timekeeping, results, communications, sanitary installations, paddock, pits, etc.

## **6. Fire fighting procedure**

## **7. Next Jury meeting**

The International Jury

The President The Secretary



**Meeting:** \_\_\_\_\_ **IMN:** \_\_\_\_\_

**Jury meeting No.**

Venue: \_\_\_\_\_ Date: \_\_\_\_\_ Time: \_\_\_\_\_

End: \_\_\_\_\_

**1. Presence:**

**1.1 Members of the Jury with voting rights**

President: \_\_\_\_\_

Member: \_\_\_\_\_

FMNR Delegate: \_\_\_\_\_

**1.2 Members of the Jury without voting rights, designated by the FIM**

FIM Technical Director: \_\_\_\_\_

Medical delegate: \_\_\_\_\_

**1.3 Clerk of the Course**

\_\_\_\_\_

**1.4 FMN delegates**

\_\_\_\_\_

**1.5 Environmental Steward**

\_\_\_\_\_

**1.6 Others**

\_\_\_\_\_

**2. Minutes of the meeting No.**

**3. Track Inspection**

**4. Technical inspections**

**4.1 Inspections carried out Total**

number of riders

number of Sidecars

## **4.2 Special checks carried out**

- noise
- weights
- others

## **5. Riders briefing**

## **6. Protests**

## **7. Rule infractions, Sanctions**

## **8. Ratification of practice results**

## **9. Report of the Clerk of the Course**

## **10. Falls/Accidents**

## **11. Starting grid**

## **12. Closed park**

## **13. Miscellaneous**

## **14. Next Jury meeting**

The International Jury

The President The Secretary



Meeting: \_\_\_\_\_ IMN: \_\_\_\_\_

**Final Jury meeting**

Venue: \_\_\_\_\_ Date: \_\_\_\_\_ Time: \_\_\_\_\_

End: \_\_\_\_\_

**1. Presence:**

**1.1 Members of the Jury with voting rights**

President: \_\_\_\_\_

Member: \_\_\_\_\_

FMNR Delegate: \_\_\_\_\_

**1.2 Members of the Jury without voting rights, designated by the FIM**

FIM Technical Director: \_\_\_\_\_

Medical delegate: \_\_\_\_\_

**1.3 Clerk of the Course**

\_\_\_\_\_

**1.4 FMN delegates**

\_\_\_\_\_

**1.5 Environmental Steward**

\_\_\_\_\_

**1.6 Others**

\_\_\_\_\_

**2. Minutes of the meeting No.**

**3. Track Inspection**

**4. Final scrutineering check**

**5. Protests**

**6. Rule infractions, Sanctions**

**7. Ratification of the results**



- 8. Dispatch of the results (by fax or e-mail) to the FIM**
- 9. Report of the Clerk of the Course**
- 10. Falls/Accidents during the races**
- 11. Unexcused absences**
- 12. Podium ceremony**
- 13. Overall impression of the meeting**

The International Jury

The President The Secretary

## 2. TECHNICAL REGULATIONS

Amendments to the Technical Regulations may be made at any time in order to ensure fairer competitions.

During practices: If a Sidecar is found not to be in conformity with the Technical Regulations during or after the practices, its rider will be given a penalty for the event such as a Ride-Through, a drop of any number of grid positions for the next race, suspension and/or withdrawal of **Championship points**.

After a Race: If a Sidecar is found not to be in conformity with the Technical Regulations after a race, its rider will be given a penalty such as a time penalty, or disqualification.

### 2.1 INTRODUCTION

- a) The FIM Sidecar World **Championship** is for vehicles with three wheels that make two or three tracks propelled by an internal combustion engine, controlled exclusively by one driver and one passenger.
- b) Providing that the following regulations are complied with, the constructors are free to be innovative with regard to design, materials and overall construction of the Sidecar vehicle.

### 2.2 TECHNICAL SPECIFICATIONS OF CHASSIS, ELIGIBILITY REQUIREMENTS

If a change to a part or system is not specifically allowed in any of the following articles, then it is forbidden.

#### 2.2.1 Materials

- a) The use of titanium in the construction of the frame, the suspensions, the steering system, the handlebars, the wheel spindles and **swinging arm spindle** is forbidden. For wheel spindles, the use of light alloys is also forbidden. The use of titanium alloy nuts and bolts is allowed.
- b) In case of doubt, **the sample/part in question shall be taken and analysed** at a Materials Testing Laboratory.

### 2.2.3 Designation of Make

When two manufacturers are involved in the construction of a Sidecar the name of both shall appear on the Sidecar as follows:

- a) The name of the chassis manufacturer
- b) The name of the engine manufacturer

### 2.2.4 Minimum weight

- a) Minimum weight fully equipped including oil, water and fuel **and fully equipped rider and passenger:**

**Short chassis with engine below the driver - 350 kg**

**Long chassis with engine behind the driver - 370 kg**

- b) A 3 kg tolerance in the weight of the Sidecar at the post-race control is accepted.
- c) The use of ballast is permitted to stay over the minimum weight limit. The weight must be reliable fixed with steel bolts (minimum 8 mm, 8.8 grade or over).

The form, the size and the weight per unit, the place of fixing and the way of fixing shall be agreed with the manufacturer of the chassis.

The use of ballast must be declared to the FIM Technical Director/ Chief Technical Steward at the preliminary technical checks.

### 2.2.5 Dimension of the Sidecar

Maximum dimensions are (see diagram A):

Maximum width: 1700 mm (including the exhaust system)

Maximum height: 800 mm (without the top air-intake - otherwise max. height: 950 mm)

Maximum length 3300 mm

Maximum wheel base: 2300 mm

### 2.2.6 Distance between tracks

- a) The distance between the tracks left by the centrelines of the rear wheel and the sidecar wheel must be at least 800 mm and not more than 1150 mm.
- b) If three tracks are made, the distance between the tracks of the rear wheel and the front wheel must not be more than 75 mm apart (see diagram A).

### 2.2.7 Riders position, protection

- a) The rider's position shall be such that the rider's feet are positioned behind the knees when looking in the riding direction. He must not be covered from above, nor be attached to the vehicle in anyway.
- b) Vehicles must have a solid and effective protection between the rider and the engine. This protection must prevent direct contact between the rider's body (or his clothes) and escaping flames or leaking fuel and oil.

### 2.2.8 Passengers position, protection

- a) The minimum dimensions of the passenger's space on the platform are (see Diagram A):

800 mm x 300 mm (may be arranged in any order).

Both measured 150 mm above the platform.

- b) Passengers shall be completely visible from above and be able to lean out to either side of the Sidecar. For this purpose, the vehicle shall be equipped with a suitable handle (grip) for the passenger to hold onto when leaning out.

Open handles for the passenger shall be ball-ended (minimum diameter 40 mm). These balls may be flattened, but in these cases any radius shall not be smaller than 8 mm.

Open handles must never reach beyond the fairing more than half the radius of the ball.

- c) Height of the protection in front of the passenger: min. 300 mm.

### **2.2.9 Streamlining**

- a) The forward extremity of the streamlining shall be not more than 400 mm in front of the foremost part of the tyre (see diagram A).
- b) The extreme rear edge of the streamlining shall be not more than 400 mm beyond the extreme edge of the rear wheel (see diagram A).
- c) The passenger shall not be covered from above, nor attached to the vehicle in anyway.

### **2.2.10 Aerodynamic devices**

Spoilers and other aerodynamic devices are authorised on condition that they do not extend beyond the overall dimensions of the bodywork and are an integral part of the fairing and/or body. These shall not exceed neither the width of the fairing nor the height of the handlebar.

Mirrors installed externally on the streamlining are prohibited. If installed within the cockpit opening it must be shatterproof. No glass is permitted.

### **2.2.11 Windscreens**

The windscreen edge and the edges of all other exposed parts of the streamlining must be rounded.

### **2.2.13 Ground clearance**

- a) The ground clearance measured over the entire length and width of the frame and other mechanical parts (engine, oil bay, exhaust and platforms) excluding the fairing, race ready, fully loaded with rider and passenger in a static racing position, shall not be less than 65 mm with the handlebars in straight position.
- b) No devices are permitted to reduce the ground clearance during the course of the race. After the race, a tolerance of -5 mm is authorised. After a “wet” race, this check is not performed.

### **2.2.14 Fixing of the Sidecar**

The chassis of the sidecar must be an integrated part of the main chassis of the vehicle. No articulation or movement between the two is allowed.

### **2.2.15 Steering**

- a) The Sidecar must be steered by the front wheel only and a handlebar.
- b) The handlebar extremities must not be lower than the front wheel spindle nor more than 500 mm behind the front wheel spindle in the straight ahead position.
- c) The steering axis must not be offset more than 75 mm from the front wheel centre line.
- d) The minimum width of handlebars is: 450 mm.
- e) The grips must be attached in such a way that at least the minimum width for handlebars is reached when measured between the outside ends of the grips.
- f) Exposed handlebar ends must be plugged with a solid material or rubber covered.
- g) The minimum angle of rotation of the handlebar and the front wheel on each side of the centre line or mid position must be 20°.
- h) Whatever the position of the handlebars the front wheel must never touch the streamlining.
- i) Solid stops, (other than steering dampers) must be fitted to ensure a minimum clearance of 20 mm between the handlebar with levers and the chassis and the streamlining, when on full lock, to prevent trapping the riders fingers.

### **2.2.16 Control levers**

All handlebar levers (clutch, brake, etc.) shall be in principle ball ended (diameter of this ball to be at least 16 mm). This ball may also be flattened, but in any case the edges must be rounded. These ends must be permanently fixed and form an integral part of the lever.

### **2.2.17 Throttle controls**

- a) Throttle controls must be self-closing when not held by the hand.
- b) Two throttle cables must be fitted (opening and closing).

- c) An ignition cut-out must be fitted to operate when the driver leaves the Sidecar. This ignition cut-out system shall interrupt the primary circuit.
- d) The ignition cut-out must be placed as near to the handlebar as possible and shall be operated by a non-elastic string of adequate length and thickness and strapped to the driver's body. A spiral cable (similar to that of a telephone wire) with a maximum length of 1 m (extended) is permitted.

### **2.2.18 Suspension**

- a) The vertical travel of the front and rear wheel spindles under suspension action shall be at least 20 mm.
- b) The use of active suspensions is forbidden.

### **2.2.19 Drive**

- a) The drive shall be transmitted to the ground only through the rear wheel of the Sidecar.
- b) Protection shields must be fitted for open transmission parts.

### **2.2.20 Wheels**

Maximum width, measured inside the flange walls of the wheel rim:

- a) front wheel: 9" / 228,6 mm
- b) rear and sidecar wheel: 11" / 279,4 mm

### **2.2.21 Tyres**

- a) The surface of the tyre may be smooth (i.e. without tread grooves), or treaded.
- b) The tread pattern is unrestricted.
- c) The surface of a slick tyre shall contain three or more hollows at 120° intervals or less, indicating the limit of wear on the centre and shoulder areas of the tyre. When at least 2 of these indicator hollows become worn on different parts of the periphery, the tyre shall no longer be used.

- d) The maximum width of the tyre tread measured from the point where the wall of the tyre finishes and the tread pattern starts, to the point where the tread pattern stops and the wall of the tyres other side starts (only the section of the tread pattern normally in contact with the ground is measured) shall not exceed:
- e) **215 mm** for front tyre.
- f) **254 mm** for rear tyre.
- g) All tyres will be measured mounted on the rim at a pressure of **1 kg/cm<sup>2</sup>** (14 lb./sq.in.).
- h) Tyre warmers are not allowed.

### **2.2.22 Mudguards and wheel protection**

- a) Mudguards must comply with the following requirements:
- b) The front mudguard shall cover at least **100°** to the rear of the circumference of the wheel, beginning at the highest point of the tyre.
- c) The Sidecar wheel must be enclosed down to the level of the Sidecar platform on the rear and on the inside, down to the height of its axle centreline at the outside.
- d) The rear wheel must be enclosed down to the level of the Sidecar platform on the inside.
- e) When the springs are compressed to their maximum, there shall still remain a minimum wheel clearance of **15 mm** to every fixed part.

### **2.2.23 Brakes**

- a) Only **steel or cast iron** brake discs are allowed. Carbon fibre brake pads are prohibited.
- b) The footbrake shall operate on all 3 wheels together.
- c) This brake-system must have two separate, operational circuits. One of the circuits shall work upon two of the three wheels.

- d) If one system fails, the other system shall work efficiently.
- e) The brake system may be operated by a hand-lever.

#### **2.2.24 Fuel tank**

- a) The fuel tank must be independently protected from the ground.
- b) Fuel must be contained in a tank securely fixed to the Sidecar. Seat tanks and exposed auxiliary tanks are forbidden. The fuel tank shall only have one fuel filler cap.
- c) Fuel tank must be completely filled with fuel cell foam (preferably with “Explosafe®”).
- d) Non-return valves must be fitted to fuel tank breather pipes.

#### **2.2.25 Fuel and oil filler caps**

- a) Fuel and oil filler caps, when closed, shall be leak proof. Additionally, they shall be securely locked to prevent accidental opening at any time.
- b) The fuel **filler** cap shall be fitted in such a way that it does not protrude in relation to the fairing or the tank profile and cannot be torn off in a crash.

#### **2.2.26 Fuel pumps**

Fuel pump(s), fuel pressure-regulator, fuel filters and fuel lines are free.

Electric fuel pumps must be wired through a circuit which will operate together with the ignition cut-out.

#### **2.2.27 Battery**

The battery must be covered in such a way that neither the rider nor the passenger may come directly into contact with the battery or its contents.

## 2.2.28 Fog Lamp

- a) Sidecars shall be equipped with a functional rear facing red anti-fog lamp.
- b) The light shall be installed at least 100 mm off the ground, located in the area between the rear wheel and the sidecar platform.

The light shall be mounted on suspended body part (i.e. platform, rear of the bodywork) and ensure no obstruction from the fairing and/or the passenger, facing to the rear (with a maximum tolerance of 5° from the longitudinal axis) of the Sidecar.

- c) In case of a 'wet' race it will be mandatory to switch on this lamp.

Only fog lamps with the following references are allowed:

- ISA - EMS - 90x90 ref. (6085-2)
- ISA - EMS - 90x92 ref. (6085-0)
- ISA - EMS - 120x65 ref. (6085-4)
- LIFELINE 90x90 Radial rain light
- LIFELINE 90x90 Radial rain light
- SCHLÜTER MOTORSPORT ref. 600500006,
- BELTENICKFIARAINLIGHTRECHTECKIG72LEDLAMPENref.600500007
- [www.isa-racing.de](http://www.isa-racing.de)
- [www.demon-tweeks.co.uk](http://www.demon-tweeks.co.uk)
- [www.rennsportshop.com](http://www.rennsportshop.com)

## 2.2.29 Number plates and backgrounds

- a) The number on the front shall be affixed in the centre of the fairing; the two side numbers shall be located on the left and right side of the fairing.

Numbers must be easily legible, of one single colour and in a clear simple font.

- b) For light coloured bodywork, there shall be a black line of maximum 8 mm all around the perimeter of the white background.

- c) The background colours and figures (numbers) are:  
**White background with black numbers. With the RAL colour table values being 9005 for black and 9010 for white.**  
**FIM number plates (3 plates: 1 in front, 1 on each side) are compulsory for the use on the participants sidecars.**
- d) The sizes for all the numbers are:  
Minimum height: 160 mm  
Minimum width: 80 mm  
Minimum stroke: 25 mm
- e) In case of dispute concerning the legibility of the numbers, the decision of the Jury President/FIM Technical Director will be final.

## **2.3 TECHNICAL SPECIFICATIONS OF ENGINE, ENGINE INSTALLATION, ELIGIBILITY REQUIREMENTS**

### **2.3.1 Engine position**

The engine must be positioned in such a way that the centre-line of the engine (by definition a position midway between centre-lines of outermost cylinders for transversal engines, or the crankshaft for in-line engines) must not exceed 160 mm beyond the centre-line of the rear wheel of the Sidecar. The engine must be positioned in front of the rear wheel (see diagram A).

### **2.3.2 Supercharging**

- a) Any kind of forced induction (turbo, compressor, etc.) is forbidden.  
b) The direct injection of fuel is not considered to be supercharging.

### **2.3.3 Displacement capacities**

**FIM homologated engines (Supersport/Superstock 600): 600cc**

### 2.3.4 Engine and transmission

**General:** If a change to a part or system is not specifically allowed in any of the following articles, then it is forbidden.

Only 4-cylinder 4-stroke engines of mass production with an FIM homologation for Supersport/Superstock 600cc are accepted.

Eligible models are listed on the FIM website ([www.fim-live.com](http://www.fim-live.com)).

Only eligible engines homologated since 01.01.2009 will be accepted.

All components must comply with the homologated engine, subject to any statements to the contrary specified in the below regulations.

The machining of components is only authorised if expressly permitted in the following rules.

The use of ceramics, metal- and polymer-based composites and alloys containing beryllium is not allowed (not applicable for coatings).

1. The crankcases must remain as homologated. Lateral (side) covers may be altered, modified or replaced.
2. Crankshaft and flywheel must remain as homologated. Balancing of the crankshaft is allowed but only **through** the boreholes necessary for this purpose. No modifications to the flywheel are permitted.
3. Connecting rods must remain as homologated.
4. Pistons, piston rings and piston pins must remain as homologated.
5. The original cylinder head must remain as homologated (no machining or polishing if not applied on the standard 'homologated' cylinder head). The cylinder head gasket may be replaced.
6. Valves, valve guides, valve seats and lower valve spring retainers must remain as homologated. Valve springs, valve keys and upper valve spring retainers may be modified or replaced.
7. The carburettor or the complete injection system (throttle body included) must remain as homologated.

Sensors and fuel injectors must be standard parts of the homologated model, with the exception of electronic and mechanical enrichment devices which may be removed.

Intake bell mouths may be removed or altered. Homologated variable length injection inlet track devices must remain as homologated by the FIM. Inlet track devices may be removed.

8. **Camshafts must remain as homologated (no kit camshafts, valve lift/cam lobe lift remains as homologated). The cam timing is free.**
9. Chain, chain-tension and chain-guides may be modified or replaced. Belt tensioning devices for belt drive systems are free.
10. Cam sprockets may be modified or replaced.
11. **The ECU (engine control unit) may be changed.** Wiring harness, spark plugs, plus wires and sockets may be replaced.
12. **Primary Transmission/Gearbox:** No modifications are permitted with the exception of shifting components to invert gear selection.

Pinions, chain sprockets, chain pitch and size may be modified. The use of an ignition breaker and a shift indicator is permitted.

13. The clutch system shall remain as originally produced by the manufacturer of the engine. Clutch springs, friction and drive discs may be altered or replaced.

Mechanical back torque limiting capabilities are permitted. No electronic or electrical support is **allowed**.

14. **The generator must supply the battery whilst the engine is running.**
15. Electric starter shall be in place and work. The engine shall start on the grid with the electric starter for the warm up lap before the start of the race.
16. Oil lubrication system is free. The oil sump and oil pump may be altered or replaced. Installation of baffle plates is allowed.

17. The original water pump may be replaced.

### **2.3.5 Air-box**

- a) An air-box shall be used. The original air-box may be replaced by an individual design.
- b) The air-box shall completely close around the induction. Bell mouths, the carburettors or throttle bodies may be entirely within the air-box.
- c) The air-box shall be constructed in such a way as to prevent any oil discharged in the air-box from spilling on the track. This oil containment shall hold a minimum of 1000cc of oil. The air-box shall be sealed to prevent any spillage of oil or fuel.
- d) The air-box intake size is not restricted.
- e) The air inlet into the air-box shall be above the lowest point of the air intake into the engine at the bell-mouth.

### **2.3.6 Oil breather systems**

All Sidecars shall have a closed breather system. The oil breather line shall be connected and discharge in the air-box, for oil containment (see Art. 2.3.5.c)

### **2.3.7 Oil cooler, Oil tank**

- a) Oil cooler shall not be mounted on or above the body of the sidecar.
- b) The location of the oil tank and oil cooler should be placed in a location where it is least likely to be damaged in an accident.

### **2.3.8 Oil drain plugs and supply pipes**

- a) All oil drain plugs shall be tight and shall be drilled and wired in position. Oil supply lines shall be correctly and securely wired in position. External oil filters and screws or bolts that enter an oil cavity shall be safety wired.



- b) Oil lines containing positive pressure, if replaced, shall be of metal reinforced construction with swaged or treaded connectors. Manufactured solid construction oil lines, where practical, shall be replaced also.
- c) It is recommended that Sidecars be equipped with a red light on the instrument panel. This light must flash in the event of oil pressure drop.

### **2.3.9 Oil and coolant containment**

- a) In the area directly below the engine, the oil containment tray shall be constructed to hold, in case of an engine breakdown the total oil and engine coolant capacity used in the engine (min. 5 litres). It must be securely affixed to the chassis.
- b) The surrounding edges of the tray shall be at least 170 mm above the bottom of the tray. Any passages for chain, chain tension device, gearshift linkage etc. must be sufficiently closed with rubber sealing bellows or sealing lips to avoid any leakage of oil spray. Holes for engine mounts (hangers) shall be sealed.
- c) This tray should incorporate a maximum of two holes of 25 mm in diameter and be closed with rubber plugs. These holes shall remain closed in dry conditions and only opened when “wet” race conditions have been declared by the Clerk of the Course.
- d) The frontal edge of the oil bay reservoir wall shall be extended upwards to arrive just below (within 20 mm) the exhaust ports of the engine.
- e) From a vertical view, the engine block shall be located completely inside the oil bay platform.
- f) The rear wheel shall be protected from any possible oil-spray. To make this protection, the engine and the rear wheel compartment shall be separated.
  - This separation shall be created by installing a solid divider (wall).

- This wall reaches from the top of the inside of the fairing and shall overlap the rear edge of the oil tray to the rear section by at least 100 mm.
  - An additional overlapping of at least 50 mm must be installed to the inside of the catch tank in the area behind the cylinder head.
- g) All sidecars shall attach oil absorbent materials of no less a quality than 3M Product number 05656 or CEP Sorbents/product number CEP-EP100.
- h) This material shall be securely fixed to the following areas of the sidecar:  
The entire tray, both the bottom and inside walls of the same.  
The volume of material used in this area, according to manufacturer's specifications, shall absorb not less than 3 litres of oil.  
The material shall be attached in such a way that it should be easily replaced, yet shall not become dislodged whilst on the track, and its effectiveness is not inhibited, i.e. if an adhesive is used it shall not clog the material, causing it to lose its absorbent properties.  
In the event that oil is absorbed by the material, it shall be replaced before the next track session.
- i) All absorbent material used, shall be non-flammable by design.

### **2.3.10 Exhaust Pipe**

- a) The exhaust pipe shall not extend beyond the width of the Sidecar and the furthest extremity of the exhaust pipe shall not exceed the vertical line drawn at a tangent to the rear edge of the Sidecar body.
- b) Exhaust pipes fitted to the side of the Sidecar shall be covered so that it is impossible for the passenger to be burnt. The ends of the exhaust pipes fitted to the Sidecar shall be so positioned or protected that it is impossible for them to become entangled with another Sidecar.
- c) The exhaust shall discharge horizontally, either to one side or to the rear, at a maximum angle of 60° to the axis of the Sidecar. The end of the silencer shall be of constant diameter over a distance of 30 mm.

### **2.3.11 Timekeeping transponder**

All Sidecars must have a correctly-positioned timekeeping transponder. The transponder must be supplied or approved by the official Timekeeper and fixed in front of the sidecar wheel, as low as possible and avoid being shielded by carbon bodywork.

Correct attachment of the transponder bracket consists of a minimum of tie-wraps, but preferably by screw or rivet. Any transponder retaining clip must also be secured by a tie-wrap.

Velcro or adhesive alone will not be accepted.

### **2.3.13 Additional electronic hardware**

Additional electronic hardware equipment not on the original homologated motorcycle may be added (this permission refers to: data acquisition and sensors, computers, recording equipment).

The addition of a device for infrared (IR) transmission of a signal between the racing rider and his team, used exclusively for lap timing, is allowed.

The addition of a GPS unit for positioning, lap timing and/or lap scoring purposes or legible messages via an on-board screen is allowed.

Telemetry is not allowed.

On-board cameras may only be used upon request and after the team has obtained written permission from the FIM.

On-board cameras, maximum two per Sidecar, will be fixed on the chassis by a TV manager assisted by a member of the team.

All Sidecars equipped with one or two on-board cameras will be checked by a Technical Steward before the qualification rounds.

## **2.10 FUEL, OIL AND COOLANTS**

- a) All sidecar engines shall function on normal unleaded fuel with a maximum lead content of 0.005 g/l (unleaded) and a maximum MON of 90 according to the FIM specifications.
- b) All riders/teams must declare to the FIM Chief Technical Steward the make and type of fuel to be used during practices and race(s), by Thursday before technical control begins.

## 2.10.1 Physical properties for unleaded fuel

### 2.10.1.2

Unleaded petrol (incl. E10) will comply with the FIM specification if:

(a) It has the following characteristics:

Property	Units	Min.	Max.	Test Method
RON		95.0	102.0	EN ISO 5164
MON		85.0	90.0	EN ISO 5163
Oxygen	% (m/m)		4.0	EN ISO 22854* or EN 13132
Nitrogen	% (m/m)		0.2	ASTM D 4629
Benzene	% (V/V)		1.0	EN ISO 22854* or EN 238
Vapour pressure (DVPE)	kPa		95.0	EN 13016-1
Lead	mg/L		5.0	ICP-OES or AAS
Manganese	mg/L		2.0	ICP-OES or AAS
Density at 15 °C	kg/m <sup>3</sup>	720.0	775.0	EN ISO 12185
Oxidation stability	minutes	360		EN ISO 7536
Existent gum	mg/100 ml		5.0	EN ISO 6246
Sulphur	mg/kg		10.0	EN ISO 20846 or 20884
Copper corrosion	rating		class 1	EN ISO 2160
Distillation:				EN ISO 3405
E at 70 °C	% (V/V)	22.0	50.0	
E at 100 °C	% (V/V)	46.0	71.0	
E at 150 °C	% (V/V)	75.0		
Final Boiling Point	°C		210	
Residue	% (V/V)		2.0	
Appearance	Clear and bright			Visual inspection
Ethanol	% (V/V)		10	EN ISO 22854
Olefins	% (V/V)		18.0	EN ISO 22854
Aromatics	% (V/V)		35.0	EN ISO 22854
Total diolefins	% (m/m)		1.0	GCMS or HPLC

## Notes:

- (1) Ethanol must be blended according to EN 15376
- (2) GC/MS methods may also be applied to fully deconvolute the GC trace
- (3) The above maximum values for olefins and aromatics are corrected for fuel oxygenates content according to clause 13.2 of ASTM D 1319:1998.
- (b) The total of individual hydrocarbon components present at concentrations of less than 5% m/m shall constitute at least 30% m/m of the fuel. The test method will be gas chromatography and/or GC/MS.
- (c) The total concentration of naphthenes, olefins and aromatics classified by carbon number shall not exceed the values given in the following table:

% (m/m)	C4	C5	C6	C7	C8	C9+
Naphthenes	0	5	10	10	10	10
Olefins	5	20	20	15	10	10
Aromatics	-	-	1.2	35	35	30

The total concentration of bicyclic naphthenes and bicyclic olefins may not be higher than 1% (m/m). The test method used will be gas chromatography.

- (d) Only the following oxygenates are permitted:  
methanol, ethanol, iso-propyl alcohol, iso-butyl alcohol, methyl tertiary butyl ether, ethyl tertiary butyl ether, tertiary amyl methyl ether, di-isopropyl ether, n-propyl alcohol, tertiary-butyl alcohol, n-butyl alcohol, secondary-butyl alcohol
- (e) Manganese is not permitted in concentrations above 2.0 mg/l. For the present this is solely to cover possible minor contamination by other fuels.
- (f) Lead replacement petrols, although basically free of lead, are not an alternative to the use of unleaded petrol. Such petrols may contain unacceptable additives not consistent with the FIM Fuel Regulations.

### 2.10.1.3

When Ethanol E85 is used, it will comply with the FIM specification and will have the following characteristics:

Property	Units	Min.	Max.	Test Method
RON		95.0	110	EN ISO 5164
MON		85.0	100	EN ISO 5163
Vapour pressure (DVPE)	kPa	35.0	95.0	EN 13016-1
Lead	g/l		0.001	ICP-OES
Manganese	g/l		0.001	ICP-OES
Oxidation stability	Minutes	360		EN ISO 7536
Existent gum	mg/100 ml		5.0	EN ISO 6246
Sulphur	mg/kg		10.0	EN ISO20846 or 20884
Copper corrosion	Rating		Class 1	EN ISO 2160
Distillation:				
Final Boiling Point	°C		210	EN ISO 3405
Residue	% (V/V)		2	EN ISO 3405
Appearance	Clear and bright			Visual inspection
Ethanol				
+ higher alcohols	% (V/V)	75		EN 13132 or 14517
Higher alcohols (C3-C8)	% (V/V)		2.0	EN 13132 or 14517
Methanol	% (V/V)		1.0	EN 13132 or 14517
Ethers				
(5 or more C atoms)	% (V/V)		5.2	EN 13132 or 14517
Unleaded petrol				
as specified in 2.10.1.2	% (V/V)	14	25	
Water	% (V/V)		0.3	EN 12937
Inorganic chloride	mg/l		1	EN 15484
Acidity	% (m/m)		0.005	EN 15491
(as acetic acid)	(mg/l)		(40)	

### 2.10.3 Air

Only ambient air may be mixed with the fuel as an oxidant.

### 2.10.4 Primary Tests

#### 2.10.4.1

The FIM may require tests of fuels to be administered before, or at the time of delivery to, an event at which such fuels are to be used.

#### 2.10.4.1

Fuel companies supplying “race” fuels (fuels other than those obtained at public fuel stations) to participating teams must submit ten litres (2 x 5 ltr) to the laboratory appointed by the FIM/DWO for analysis in accordance with the specification. Providing the fuel is within the specification, a certificate containing a test report number will be issued to the fuel company. Contact for fuel analysis: [fimfuels@intertek.com](mailto:fimfuels@intertek.com).

### 2.10.5 Fuel Sampling and Testing

1. The FIM Technical **Director** has the sole responsibility for the administration and supervision during the taking of fuel samples.
2. Sidecars selected for fuel controls will usually be amongst the first three finishers, and will be directed to the “**Parc Fermé**” and the fuel tanks removed for weight controls.
3. Other finishers will be chosen at random for fuel controls. A Technical Steward will be posted at the entrance to the pit box of the selected team.

Fuel sampling may take place in the pit box or in the “**Parc Fermé**”.

4. The fuel to be tested will be transferred into two bottles (2 samples of maximum 1 ltr each), marked “A” and “B” and identified by reference to the Sidecar from which the sample was taken. The bottles will be closed, sealed and labelled by the FIM Technical **Director/Chief Technical Steward**.
5. Only new samples bottles will be used for the fuel samples.

6. The Fuel Sample Declaration form will be filled out immediately, containing all information as shown in the example sheet, including the riders and Sidecars identity, date and place of fuel sampling. A responsible team member will sign this declaration, after verifying that all the information is correct.
7. Sample “A” will be sent to the FIM appointed laboratory, accompanied by a copy of the Fuel Sample Declaration form. Costs for the analyses of sample “A” will be paid by FIM.
8. Sample “B” will be handed over to the FIM for safeguarding in case of protests and/or requirement of a counter-expertise by the FIM appointed laboratory. Costs for the analyses of sample “B” will be paid by the team concerned.
9. Both samples will be transported by an authorised courier.
10. The laboratory must deliver the results of the fuel sample analyses to the FIM, as soon as possible after receipt of the samples, and before the Friday evening of the following event.
11. In the case of non-conformity, the laboratory shall notify, as soon as practical after receipt of the results, the FIM, the International Jury and the rider/team representative concerned.

Within 48 hours of the receipt of the notification of the results of the laboratory test of sample “A”, the team shall notify the FIM and the International Jury, if counter-expertise is required (or not required) for sample “B”.

Failure of the sample to correspond to the FIM fuel specifications will automatically result in the disqualification of the competitor. The result of the competitor’s fuel sample analysis (“A” or “B” sample) more favourable to the competitor will be taken into account.

#### **2.10.6 Fuel Storage**

Where the fuel is supplied by the Organiser, there shall be a officially designated and controlled fuel storage areas. Outside these areas, fuel may only be stored in metal containers.

A maximum of 60 litres of fuel, stored in a sealable container, is allowed in the competitor's pit.

The officially designated storage and supply area shall be in conformity with the building criteria. Firefighting equipment, protective devices and staff shall conform to the requirements imposed by the local authorities and by-laws.

The organiser shall have fire extinguishers of a size and type approved by the local by-laws, available to each competitor in the pit area.

## **2.10.7 Coolants**

The only liquid engine coolant permitted other than lubricating oil shall be water.

## **2.11 PROTECTIVE CLOTHING AND HELMETS**

### **2.11.1**

Riders must wear a complete leather suit with additional leather padding or other protection on the principal contact points, knees, elbows, shoulders, hips etc.

### **2.11.2**

Linings or undergarments must not be made of a synthetic material which might melt and cause damage to the riders' skin.

### **2.11.3**

Riders must also wear leather gloves and boots, which with the suit provide complete coverage from the neck down.

### **2.11.4**

Leather substitute materials may be used, providing they have been checked by the Chief Technical Steward.

### **2.11.5**

Use of a back protector is highly compulsory.

### 2.11.6

Riders must wear a helmet which is in good condition, provides a good fit and is properly fastened.

### 2.11.7

Helmets must be of the full face type and conform to one of the recognised international standards:

<b>EUROPE</b>	<b>ECE 22-05 (only “P” type)</b>
<b>JAPAN</b>	<b>JIS T 8133:2007 (valid until 31.12.2019) JIS T 8133:2015 (only “Type 2 Full face”)</b>
<b>USA</b>	<b>SNELL M 2010 (valid until 31.12.2019) SNELL M 2015</b>

Examples of labels are reported below (for Europe, the country numbers which have granted the approval are also indicated)

<b>EUROPE</b>	 <p><b>051406/J-1952</b> </p> <p style="text-align: right;">a = 8 mm min.</p> <p>3/ 1 for Germany, 2 for France, 3 for Italy, 4 for the Netherlands, 5 for Sweden, 6 for Belgium, 7 for Hungary, 8 for the Czech Republic, 9 for Spain, 10 for Yugoslavia, 11 for the United Kingdom, 12 for Austria, 13 for Luxembourg, 14 for Switzerland, 15 (vacant), 16 for Norway, 17 for Finland, 18 for Denmark, 19 for Romania, 20 for Poland, 21 for Portugal, 22 for the Russian Federation, 23 for Greece, 24 for Ireland, 25 for Croatia, 26 for Slovenia, 27 for Slovakia, 28 for Belarus, 29 for Estonia, 30 (vacant), 31 for Bosnia and Herzegovina, 32 for Latvia, 33 (vacant), 34 for Bulgaria, 35 (vacant), 36 for Lithuania, 37 for Turkey, 38 (vacant), 39 for Azerbaijan, 40 for The former Yugoslav Republic of Macedonia, 41 (vacant), 42 for the European Community (Approvals are granted by its Member States using their respective ECE symbol), 43 for Japan, 44 (vacant), 45 for Australia, 46 for Ukraine, 47 for South Africa and 48 for New Zealand. Subsequent numbers shall be assigned to other countries in the chronological order in which they ratify or accede to the Agreement Concerning the Adoption of Uniform Technical Prescriptions for Wheeled Vehicles, Equipment and Parts which can be Fitted and/or be Used on Wheeled Vehicles and the Conditions for Reciprocal Recognition of Approvals Granted on the Basis of these Prescriptions, and the numbers thus assigned shall be communicated by the Secretary-General of the United Nations to the Contracting Parties to the Agreement.</p>
---------------	---

JAPAN	 
USA	 

### 2.11.8

Visors must be made of a shatterproof material.

### 2.11.9

Disposable “tear-offs” are permitted.

### 2.11.10

Any question concerning the suitability or condition of the riders clothing and/or helmet shall be decided by the FIM Technical Director/Chief Technical Steward, who may, if he so wishes, consult with the manufacturers of the product before making a final decision.

## 2.12 PROCEDURE FOR TECHNICAL CONTROL

### 2.12.1

The rider is at all times responsible for his Sidecar.

### 2.12.2

The Chief Technical Steward must be in attendance for an event at least 1 hour before the technical verifications are due to beginning. He must inform the Clerk of the Course, the Jury President and the FIM Technical Director of his arrival.

### 2.12.3

He must ensure that all Technical Stewards, appointed for the event, carry out their duties in a proper manner.

### 2.12.4

He shall appoint the Technical Stewards to individual posts for the race, practices and final control.

### 2.12.5

One rider, or his mechanic, must be present with the Sidecar for Technical control within the time limits stated in the Supplementary Regulations. The maximum number of persons present at the technical verification will be the rider, plus two others. In addition, the Team Manager will also be allowed.

### 2.12.6

The FIM Technical **Director**/Chief Technical Steward must inform the International Jury of the results of the Technical control. The FIM Technical **Director**/Chief Technical Steward will then draw up a list of accepted Sidecars and submit this list to the Clerk of the Course.

### 2.12.7

The FIM Technical **Director**/Chief Technical Steward have the right to inspect any part of the Sidecar at any time of the event.

### 2.12.8

Any rider failing to report as required below may be disqualified from the event. The International Jury may forbid any team who does not comply with the rules, or any rider who may be a danger to other participants or to spectators, to take part in the practice sessions or in the races.

### 2.12.9

The Technical Control must be carried out in accordance with the procedure and times fixed in the Supplementary Regulations of the event.

### 2.12.10

The FIM Technical **Director**/Chief Technical Steward will refuse any Sidecar that does not have a correctly-positioned positive transponder attachment. The transponder must be fixed to the Sidecar in the position and orientation as shown in the Timekeeping information given to teams pre-season and available at each event. Positive attachment of the transponder bracket consists of a minimum of tie-wraps, but preferably by screw or rivet. Velcro or adhesive alone will not be accepted. The transponder retaining clip shall also be secured by a tie-wrap.



### 2.12.11

The rider or the mechanic shall present a clean Sidecar and in conformity to the FIM rules. He shall also present a duly filled in and confirmed Technical Card

### 2.12.12

An overall inspection of the Sidecar must be carried out in conformity with the FIM rules. Accepted Sidecars will be marked with paint or a sticker.

### 2.12.13

FIM Technical **Director**/Chief Technical Steward has the final authority in case of a dispute on the conformity of the parts in question and for acceptance thereof.

### 2.12.14

Before each practice the Chief Technical Steward must confirm that the Sidecar has passed the Technical Control by checking the Technical Control sticker before the Sidecars go on the track.

### 2.12.15

Only accepted Sidecars may be used in practices and races.

### 2.12.16

Approximately 30 minutes after the Technical control have been completed, the FIM Technical **Director**/Chief Technical Steward must submit to the International Jury a list of accepted Sidecars and riders.

### 2.12.17

If a Sidecar is involved in an accident, the FIM Technical **Director**/Chief Technical Steward must check the Sidecar, together with the helmet and clothing of the rider involved, to ensure that no defect of a serious nature has occurred.

If a Sidecar was stopped with a Black Flag with Orange Disc, the FIM Technical **Director**/Chief Technical Steward must check the Sidecar.

In both cases, it is the responsibility of the team to present the Sidecar (together with helmet and clothing of the fallen rider) for his re-examination in case they wish to continue.

If the helmet is clearly defective, the Chief Technical Steward must retain this helmet. The organiser must send this helmet, together with the accident and medical report (and pictures and video, if available) to the Federation of the rider. If there are head injuries stated in the medical report, the helmet then must be sent to a neutral institute for examination.

## 2.13 VERIFICATION GUIDELINES FOR TECHNICAL STEWARDS

Make sure all necessary measures and administrative equipment are in place at least 1 hour before the Technical control (see separate list) is due to open (time in Supplementary Regulations).

Decide who is doing what and note decisions. “Efficiency” must be the watchword. Always keep cheerful and remember the reasons for Technical controls: SAFETY AND FAIRNESS.

Be well informed. Make sure your FMN has supplied you with all technical “updates” that may have been issued subsequent to the printing of the Technical Rule Books. Copies of all homologation documents shall be in your possession.

Inspection must take place under cover with a large enough area (min. surface 100 sq. metres) to handle the technical verifications in two lines.

Weighing apparatus must be accurate and practical. Certified master weights and their certificate must be available for the Technical checks.

Rules regarding sound level and measurement must be respect.

### 1) Preparations, procedures

- At each circuit, an area must be designated as the Technical Control Area. In this area, under the control of the FIM Technical Director/ Chief Technical Steward, suitable equipment will be available to conduct proper inspections.



- The Technical Control will be carried out in accordance with the schedule set out in the Supplementary Regulations.
- Technical Stewards must be available throughout the entire event to check Sidecars and equipment as required by the FIM Technical **Director/Chief Technical Steward**.
- Presentation of a Sidecar will be deemed as an implicit statement of conformity with the Technical Regulations.
- The Technical Stewards must inspect the Sidecars for obvious safety omissions.
- The Technical Stewards must inspect that the Sidecar conforms to all Technical Rules laid out in the Regulations.
- All Sidecars will be required for weight and/or sound check at the pre-race Technical Inspection.
- The scales and sound meter will be available to the teams or riders for pre-race checking in the Technical Control Area.
- Noise test should take place in a clear area adjacent to the Technical Control at least 10 meters from any possible sound reflecting obstruction.
- The riders must be aware that the weight and sound may be controlled at random during practice in the pit-lane and at the end of the race.
- Claiming that the sound and weight were not officially controlled before the race will not be grounds for appeal. Conformity of the rules is the responsibility of the rider.
- The FIM Technical **Director/Chief Technical Steward** reserves the right to spot check the weight and sound of any Sidecars on pit row during free practice and official practice. This may occur at any time during the free practice and in the first forty minutes of any official (timed) practice. This will be carried out with the least possible inconvenience to the rider.

- Sidecars arriving later than the first free practice must be controlled in the Technical Control Area.
- At the conclusion of the inspections, a small sticker or coloured mark will be placed on the frame indicating that the Sidecar had passed inspection.
- The Technical Stewards must re-inspect any Sidecar that has been involved in an accident.
- The Technical Stewards must be available, based on instructions from the FIM Technical **Director**/Chief Technical Steward, to re-inspect any Sidecar for technical compliance during the event.
- During the Technical Inspection in the closed park the mechanics must assist with the inspections. A maximum of two (2) team members per rider is allowed in the closed park during the post-race technical inspection. Downloading of data is allowed in the closed park.
- Representatives of the tyre manufacturers are allowed in the closed park.

## 2) Practice

**Dry Practice:** Every Sidecar used in free or official practice may be checked. The minimum checks are weight and sound.

- The FIM Technical **Director**/Chief Technical Steward may request other checks.

**Wet practice:** The FIM Technical **Director**/Chief Technical Steward may perform certain checks during/after a wet practice.

## 3) Final inspection at the end of the race

Sidecars may be checked at least for the following compliance points:

- **Weight:** The weight will be checked in the condition that the Sidecar has finished the race. No elements may be added to the Sidecar, **neither any type of ballast**, fuel, oil, water, nor tyres.



- Sound: compliance with max noise limit.
- Throttle bodies and injectors: Measurement and inspection of both inlet- and outlet tracts and **points on the homologated fuel injection system.**
- Engine: Engine(s), chosen at random, may be checked internally for capacity and compliance with Art. 2.3.

The FIM Technical **Director**/Chief Technical Steward may require a team to provide parts or samples, as he may deem necessary to confirm compliance with the rules.

#### 4) **Appointment and attendance**

The Technical Stewards shall be present and available during the opening hours of the Technical Control Area. The FIM Technical **Director**/Chief Technical Steward will instruct the Technical Stewards to verify Sidecars for compliance with technical and safety rules.

#### 5) **Administration day/Technical control:**

For all teams: 3 persons

Tasks: Inspection of Sidecar safety, clothing and helmets

(NO SOUND OR WEIGHT CONTROL)

Administration tasks: 1 person

a) Saturday:

Technical control: free practice and official qualifying sessions

Task: Inspection of Sidecar safety: Sound and Weight: 3 persons

Inspection of crashed Sidecars and Technical controls : 2 persons

Administration tasks: 1 person

## b) Sunday:

Technical control during race day

Before race: safety checks on start grid as required

After race:

Technical control noise, weight  
and carburation instruments 3 persons

Displacement checks 2 persons

Administration tasks 1 person

## NOTE:

This is the required minimum of Technical Stewards. The number may of course be higher.

All final verification points to be decided in co-operation with the International Jury President and the FIM Technical Director/Chief Technical Steward.

Post-race checks are under extreme pressure. It is important to be very well organised.

The Chief Technical Steward must report to the Jury after the final verifications.

6) Minimum Equipment list

- Revolution meter
- Sound meter and calibrator
- Slide calliper
- Depth gauge
- Steel measuring tape
- Seals
- Weighing apparatus (scales) with calibration weights
- Tools for measuring engine capacity
- Tools for measuring valve lift
- Weighing apparatus for investigation of valve weights
- Colour for marking parts
- Magnet for materials testing
- Computer to read homologation lists on CD-Rom or memory stick

## 7) Documents list

- **Sidecar World Championship Regulations of the current year**
- Supplementary Regulations
- Homologation documents
- CD-Rom or memory stick with homologations
- Technical control forms
- Writing materials

### 2.14 SOUND CONTROL

- a) **Maximum sound level:** 107 dB/A (see also 2.14.5)  
(with a 3 dB/A tolerance after the race )
- b) **Sound will be controlled as below:**

#### 2.14.1

With the microphone placed at 50 cm from the exhaust pipe at an angle of 45° measured from the centre-line of the exhaust end and at the height of the exhaust pipe, but at least 20 cm above the ground. If this is not possible, the measurement may be taken at 45° upwards.

#### 2.14.2

During a sound test, sidecars not equipped with a gear box neutral shall be placed on a stand.

#### 2.14.3

The silencers will be marked when they are checked and it is not allowed to change them after the verification, except for any spare silencer which has also been checked and marked.

#### 2.14.4

The driver shall keep his engine running out of gear and shall increase the engine speed until it reaches the specified revolutions per minute (RPM). Measurements shall be taken when the specified RPM is reached.

#### 2.14.5

The RPM depends upon the mean piston speed corresponding to the stroke of the engine.

The RPM will be given by the relationship:

$$N = \frac{30,000 \times cm}{l}$$

in which N = prescribed RPM of engine  
 cm = fixed mean piston speed in m/s  
 l = stroke in mm

#### 2.14.6

Due to the similarity of the piston stroke in different engine configurations within the capacity classes, the sound test will be conducted at a fixed RPM.

**600 cc - 4-cylinder 4-stroke                      7.000 RPM**

(For reference only, the mean piston speed at which the sound test is conducted is calculated at 11 m/sec.)

#### 2.14.7

The sound level for engines with more than one **silencer** will be measured on each exhaust end.

#### 2.14.8

A Sidecar which does not comply with the sound limits may be presented several times at pre-race control.

#### 2.14.9

After the race, the sound limit shall not exceed: 107 dB/A (with a tolerance of 3 dB/A).

#### 2.14.10

Apparatus for sound control shall be to international standard IEC 651, with a Type 1 meter (Grade 1)

#### 2.14.11

The sound level meter shall be equipped with a calibrator for control and adjustment of the meter during periods of use.

#### 2.14.12

The “slow response” setting shall always be used.

### 2.14.13

There is no influence of temperature on sound tests.

### 2.14.14      **Sound control after the competition**

In a competition which requires a final examination of Sidecars before the results are announced, this examination shall include a sound control measurement of at least the first three Sidecars listed in the final classification.

At this final test, there will be a 3 dB/A tolerance.

## 2.15              **GUIDELINES FOR USE OF SOUND LEVEL METERS**

### 2.15.1

The Sound Control Officer (SCO) must arrive in sufficient time for discussions with the FIM Technical **Director** and other Technical Stewards in order that a suitable test site and testing policy may be agreed.

### 2.15.2

Sound level measuring equipment must include a compatible calibrator, which shall be used immediately before testing begins and always just prior to a re-test if a disciplinary sanction may be imposed.

Two sets of equipment must be available in case of failure of tachometer, sound level meter or calibrator during technical control.

### 2.15.3

Before testing, the SCO must calibrate the sound test equipment with a calibrator, in order check the accuracy of the official sound meter.

### 2.15.4

Tests can take place in rain or damp conditions. Sidecars considered excessively noisy must be individually tested if conditions allow.

### 2.15.5

In other than moderate wind, Sidecars should face forward in the wind direction. (Mechanical sound will blow forward, away from microphone).

### 2.15.6

“Slow” meter response shall be used.

### 2.15.7

“A” weighted setting on sound level meter.

### 2.15.8

There is no rounding down of the meter reading:

107.9 dB/A = 107.9 dB/A.

### 2.15.9

Correction: Type 1 meter: deduct 1 dB/A

**Type 1 (preferred) for use during FIM Championships and Prize events.**



---

**3. DISCIPLINARY AND ARBITRATION CODE**

The regulations will be defined by the “FIM DISCIPLINARY AND ARBITRATION CODE”.



---

**4. CIRCUIT STANDARDS**

Circuit standards will be defined by the “FIM STANDARDS FOR CIRCUITS”



---

**5. MEDICAL CODE**

The regulations will be defined by the “FIM MEDICAL CODE”.



---

**6. ANTI-DOPING CODE**

The regulations will be defined by the “FIM ANTI-DOPING CODE”.



---

## **7. ENVIRONMENTAL CODE**

The regulations will be defined by the “FIM ENVIRONMENTAL CODE”.



---

**8. CODE OF ETHICS**

The regulations will be defined by the “FIM CODE OF ETHICS”.

## Rule changes as of 01/01/2018

### 2.10.1.2

Unleaded petrol (incl. E10) will comply with the FIM specification if:

It has the following characteristics:

Property	Units	Min.	Max.	Test Method
RON		95.0	102.0	EN ISO 5164 or ASTM D2699
MON		85.0	90.0	EN ISO 5163 or ASTM D2700
Oxygen (includes 10% ethanol allowance)	% (m/m)		3.7	ISO 22854 or EN 13132 or elemental analysis
Nitrogen	% (m/m)		0.2	ASTM D 4629 or ASTM 5762
Benzene	% (V/V)		1.0	ISO 22854 or ASTM D6839 or ASTM D5580
Vapour pressure (DVPE) (for winter events)	kPa		95.0 (100.0)	EN 13016-1 (ASTM D5191)
Lead	mg/L		5.0	ICP-OES or AAS
Manganese	mg/L		2.0	ICP-OES or AAS
Density at 15°C	kg/m <sup>3</sup>	720.0	785.0	EN ISO 12185 or ASTM D4052
Oxidation stability	minutes	360		EN ISO 7536 or ASTM D525
Sulphur	mg/kg		10.0	EN ISO 20846 or ASTM D5453
Distillation:				EN ISO 3405 or ASTM D86
E at 70°C	% (V/V)	20.0	50.0	
E at 100°C	% (V/V)	46.0	72.0	
E at 150°C	% (V/V)	75.0		

<b>Final Boiling Point</b>	<b>°C</b>		<b>210</b>	
<b>Residue</b>	<b>% (V/V)</b>		<b>2.0</b>	
<b>Appearance</b>	<b>Clear and bright</b>			<b>Visual inspection</b>
<b>Olefins</b>	<b>% (V/V)</b>		<b>18.0</b>	<b>EN ISO 22854 or ASTM D6839</b>
<b>Aromatics</b>	<b>% (V/V)</b>		<b>35.0</b>	<b>EN ISO 22854 or ASTM D6839</b>
<b>Total diolefins</b>	<b>% (m/m)</b>		<b>1.0</b>	<b>GC-MS or HPLC</b>
<b>Oxygenates:</b>				<b>EN ISO 22854 or EN 13132</b>
<b>Methanol</b>	<b>% (V/V)</b>		<b>3.0</b>	<b>The only oxygenates permitted are paraffinic mono-alcohols and paraffinic mono-ethers (of 5 or more carbon atoms per molecule) with a final boiling point below 210°C.</b>
<b>Ethanol (1)</b>	<b>% (V/V)</b>		<b>5.0</b>	
<b>Ethanol (E10) (1)</b>	<b>% (V/V)</b>	<b>5.0</b>	<b>10.0</b>	
<b>Isopropanol</b>	<b>% (V/V)</b>		<b>12.0</b>	
<b>Isobutanol</b>	<b>% (V/V)</b>		<b>15.0</b>	
<b>tert-Butanol</b>	<b>% (V/V)</b>		<b>15.0</b>	
<b>Ethers (C5 or higher)</b>	<b>% (V/V)</b>		<b>22.0</b>	
<b>Others (2)</b>	<b>% (V/V)</b>		<b>15.0</b>	

- a) The total of individual hydrocarbon components present at concentrations of less than 5% (m/m) must constitute at least 30% (m/m) of the fuel. The test method will be gas chromatography and/or GC/MS.

- b) The total concentration of naphthenes, olefins and aromatics classified by carbon number must not exceed the values given in the following table:

% (m/m)	C4	C5	C6	C7	C8	C9+
Naphthenes	0	5	10	10	10	10
Olefins	5	20	20	15	-	-
Aromatics	-	-	1.2	35	-	-

The total concentration of bicyclic naphthenes and bicyclic olefins may not be higher than 1% (m/m). The test method used will be gas chromatography.

- c) Lead replacement petrols, although basically free of lead, are not an alternative to the use of unleaded petrol. Such petrols may contain unacceptable additives not consistent with the FIM Fuel Regulations.



FIM SIDECAR WORLD CHAMPIONSHIP

FUEL SAMPLES TAKEN ON ..... /..... / ..... FOR LABORATORY ANALYSIS

RACE N°:	Sample May "A"	
	May Label N°	May Seal N°
RIDER:	Sample May "B"	
	May Label N°	May Seal N°

SIDECAR MAKE: \_\_\_\_\_

TEAM: \_\_\_\_\_

The above listed details refer to fuel samples taken from the fuel tank of the Sidecar specified after the race whilst in the Check Area for a period of 60 minutes pending any protest.

Sample "A" will go to the laboratory appointed by the FIM for analysis. Sample "B" will be safeguarded by the FIM in case a counter-expertise is required.

As a responsible member of the team named on this sheet, I,

(print name): \_\_\_\_\_

have controlled the serial numbers of may seals and serial numbers of may labels and hereby certify the accuracy of the listed information.

Time: \_\_\_\_\_  
(Signature)

Position in team: \_\_\_\_\_  
(OWNER/MANAGER/MECHANIC)

DIAGRAM A

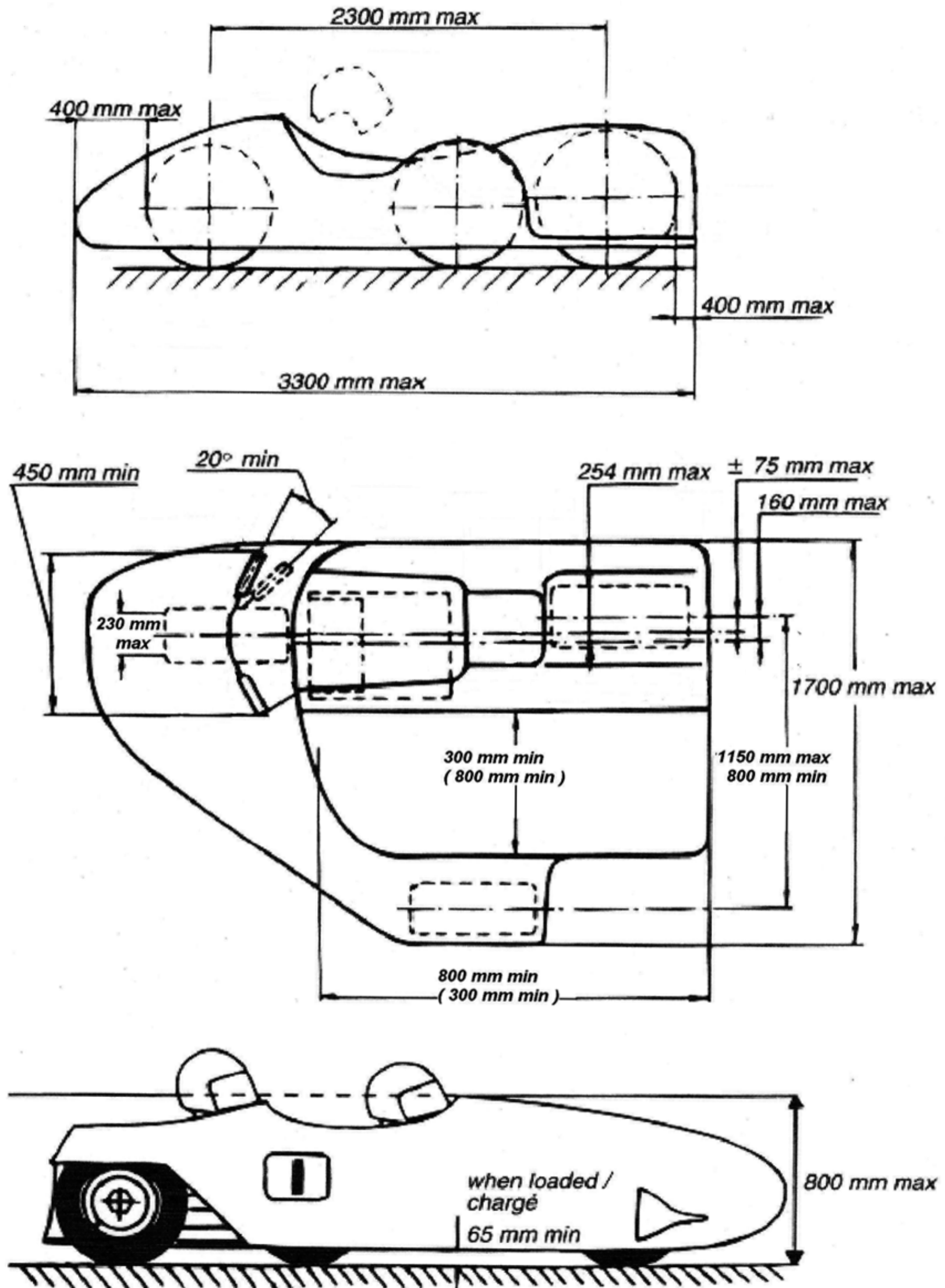

# NUMBERS/NUMEROS

0

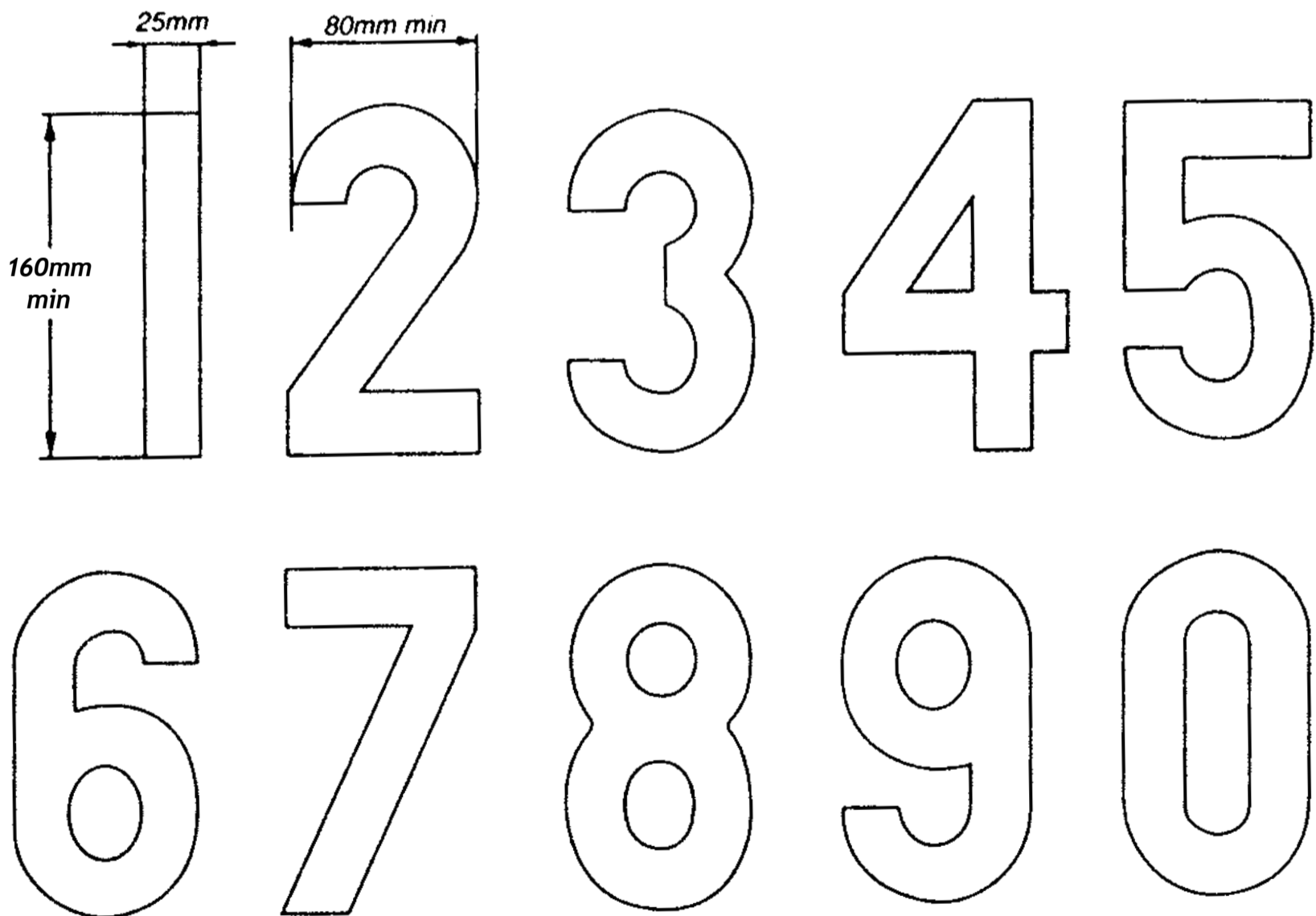
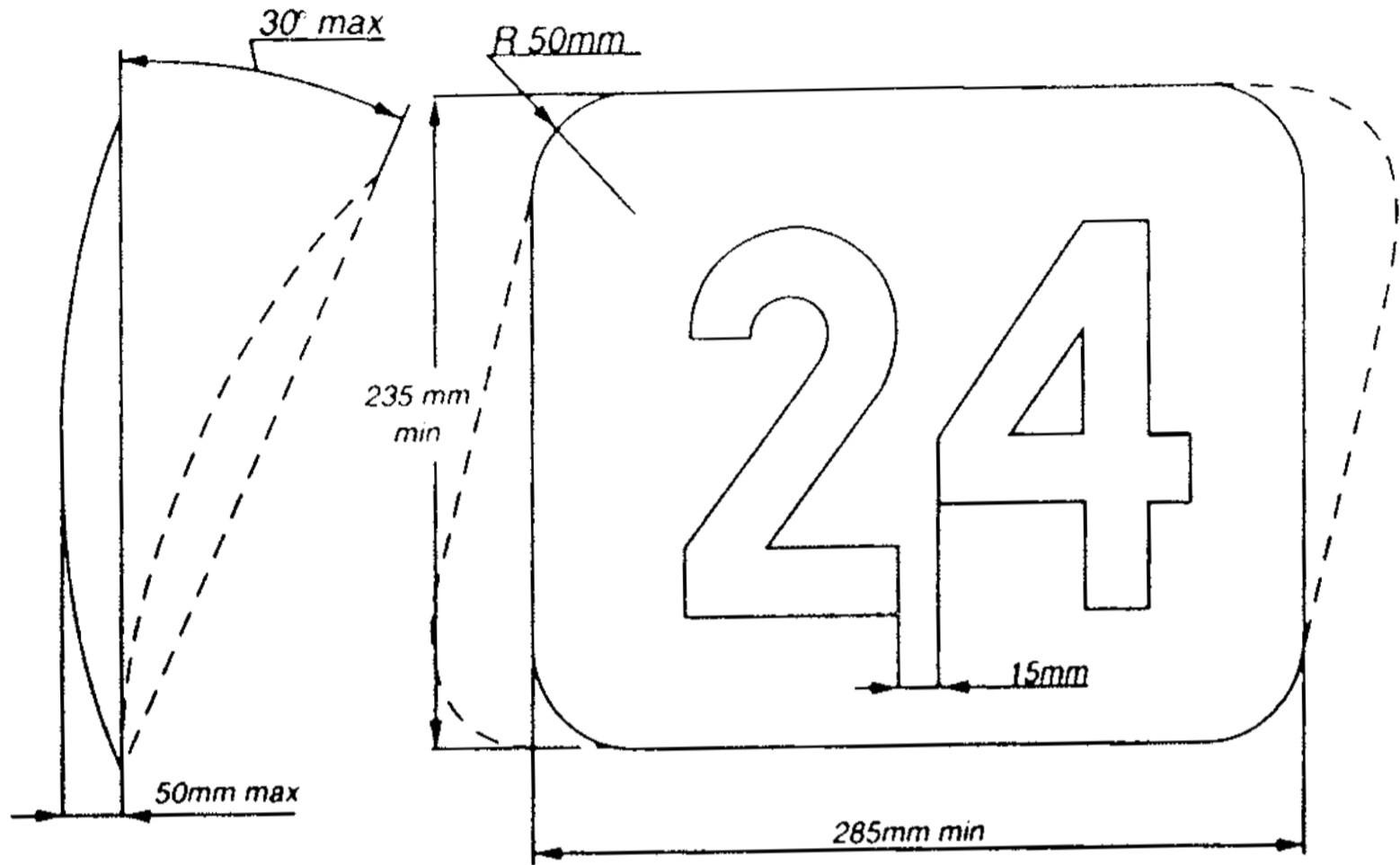



**Futura Heavy**

**0 1 2 3 4 5 6 7 8 9**

**Futura Heavy Italic**

***0 1 2 3 4 5 6 7 8 9***

**Univers Bold**

**0 1 2 3 4 5 6 7 8 9**

**Univers Bold Italic**

***0 1 2 3 4 5 6 7 8 9***

**Oliver Med.**

**0 1 2 3 4 5 6 7 8 9**

**Oliver Med. Italic**

***0 1 2 3 4 5 6 7 8 9***

**Franklin Gothic**

**0 1 2 3 4 5 6 7 8 9**

**Franklin Gothic Italic**

***0 1 2 3 4 5 6 7 8 9***

## **TEN FITTING TESTS FOR HELMETS** **DIX TESTS D'ADAPTATION POUR LES CASQUES**

1. *Obtain correct size by measuring the crown of the head*  
Avoir la bonne grandeur en mesurant le sommet de la tête
2. *Check there is no side to side movement*  
Vérifier qu'il n'y ait pas de déplacement d'un côté à l'autre
3. *Tighten strap securely*  
Serrer solidement la jugulaire
4. *With head forward, attempt to pull up back of helmet to ensure helmet cannot be removed this way*  
Tête en avant, essayer de soulever le casque pour s'assurer qu'il ne peut pas être enlevé de cette façon



5. *Check ability to see clearly over shoulder*  
Vérifier si vous pouvez voir clairement par-dessus l'épaule
6. *Make sure nothing impedes your breathing in the helmet and never cover your nose or mouth*  
S'assurer que rien ne gêne votre respiration dans le casque et ne jamais couvrir le nez ou la bouche
7. *Never wind scarf around neck so that air is stopped from entering the helmet. Never wear scarf under the retention strap*  
Ne jamais enrouler une écharpe autour du cou, car cela empêche l'air d'entrer dans le casque. Ne jamais porter d'écharpe sous la jugulaire
8. *Ensure that visor can be opened with one gloved hand*  
S'assurer que la visière peut être ouverte avec une main gantée
9. *Satisfy yourself that the back of your helmet is designed to protect your neck*  
S'assurer que l'arrière de votre casque a une forme telle qu'il vous protège la nuque
10. *Always buy the best you can afford*  
Toujours acheter le meilleur que vous pouvez vous offrir



FÉDÉRATION INTERNATIONALE  
DE MOTOCYCLISME

**FIM-LIVE**.com

11, ROUTE DE SUISSE | CH - 1295 MIES

ccr@fim.ch

6510007